

**Standard** ECMA-386

1<sup>st</sup> Edition / December 2008

**NFC-SEC-01:  
NFC-SEC Cryptography  
Standard using ECDH  
and AES**

**Standard**



Standard  
ECMA-386

1<sup>st</sup> Edition / December 2008

---

**NFC-SEC-01**  
**NFC-SEC Cryptography**  
**Standard using ECDH and**  
**AES**

---



## Introduction

The NFC-SEC series of standards comprise a common services and protocol Standard and NFC-SEC cryptography standards.

This NFC-SEC cryptography Standard specifies cryptographic mechanisms that use the Elliptic Curves Diffie-Hellman (ECDH) protocol for key agreement and the AES algorithm for data encryption and integrity.

This Standard addresses secure communication of two NFC devices that do not share any common secret data ("keys") before they start communicating with each other.

This Ecma Standard has been adopted by the General Assembly of December 2008.

---



## Table of contents

<b>1</b>	<b>Scope</b>	<b>1</b>
<b>2</b>	<b>Conformance</b>	<b>1</b>
<b>3</b>	<b>References</b>	<b>1</b>
<b>4</b>	<b>Definitions</b>	<b>1</b>
<b>5</b>	<b>Conventions and notations</b>	<b>1</b>
5.1	Concatenation	1
5.2	Hexadecimal numbers	1
<b>6</b>	<b>Acronyms</b>	<b>2</b>
<b>7</b>	<b>General</b>	<b>3</b>
<b>8</b>	<b>NFC-SEC-01 Protocol Identifier (PID)</b>	<b>3</b>
<b>9</b>	<b>NFC-SEC-01 Primitives</b>	<b>3</b>
9.1	Key agreement	3
9.1.1	Curve P-192	3
9.1.2	EC Key Pair Generation Primitive	4
9.1.3	EC Public key validation	4
9.1.4	ECDH secret value derivation Primitive	4
9.1.5	Random nonces	4
9.2	Key Derivation Functions	4
9.2.1	KDF for the SSE	4
9.2.2	KDF for the SCH	4
9.3	Key Usage	5
9.4	Key Confirmation	5
9.4.1	Key confirmation tag generation	5
9.4.2	Key confirmation tag verification	5
9.5	Data Encryption	5
9.5.1	Initial value of counter (IV)	5
9.5.2	Encryption	6
9.5.3	Decryption	6
9.6	Data Integrity	6
9.6.1	Protect data integrity	6
9.6.2	Check data integrity	6

9.7	Message Sequence Integrity	6
<b>10</b>	<b>Data Conversions</b>	<b>6</b>
10.1	Integer-to-Octet-String Conversion	6
10.2	Octet-String-to-Integer Conversion	6
10.3	Point-to-Octet-String Conversion	7
10.4	Octet-String-to-Point Conversion	7
<b>11</b>	<b>SSE and SCH service invocation</b>	<b>8</b>
11.1	Pre-requisites	8
11.2	Key Agreement	9
11.2.1	Sender (A) Transformation	9
11.2.2	Recipient (B) Transformation	9
11.3	Key Derivation	10
11.3.1	Sender (A) Transformation	10
11.3.2	Recipient (B) Transformation	10
11.4	Key Confirmation	10
11.4.1	Sender (A) Transformation	10
11.4.2	Recipient (B) Transformation	10
<b>12</b>	<b>SCH data exchange</b>	<b>11</b>
12.1	Preparation	11
12.2	Data Exchange	12
12.2.1	Send	12
12.2.2	Receive	12
<b>Annex A (normative) AES-XCBC-PRF-128 and AES-XCBC-MAC-96 algorithms</b>		<b>13</b>
<b>Annex B (normative) NFC-SEC-01 fields sizes</b>		<b>15</b>
<b>Annex C (informative) Informative references</b>		<b>17</b>

## 1 Scope

---

This Standard, NFC-SEC-01 specifies the message contents and the cryptographic methods for PID 01.

This Standard specifies cryptographic mechanisms that use the Elliptic Curves Diffie-Hellman (ECDH) protocol for key agreement and the AES algorithm for data encryption and integrity.

## 2 Conformance

---

Conformant implementations employ the security mechanisms specified in this NFC-SEC cryptography Standard (identified by PID 01) and conform to ECMA-385.

The NFC-SEC security services shall be established through the protocol specified in ECMA-385 and the mechanisms specified in this Standard.

## 3 References

---

ECMA-385	NFC-SEC: NFCIP-1 Security Services and Protocol
ISO/IEC 10116:2006	Information technology -- Security techniques -- Modes of operation for an n-bit block cipher
ISO/IEC 11770-3:2008	Information technology -- Security techniques -- Key management -- Part 3: Mechanisms using asymmetric techniques
ISO/IEC 15946-1:2008	Information technology -- Security techniques -- Cryptographic techniques based on elliptic curves -- Part 1: General
ISO/IEC 18031:2005	Information technology -- Security techniques -- Random bit generation
ISO/IEC 18033-3:2005	Information technology -- Security techniques -- Encryption algorithms -- Part 3: Block ciphers
IEEE 1363	IEEE Standard Specifications for Public-Key Cryptography
FIPS 186-2	Digital Signature Standard (DSS)

## 4 Definitions

---

For the purposes of this Standard, all terms and definitions from ECMA-385 apply.

## 5 Conventions and notations

---

The conventions and notations of ECMA-385 as well as the following apply in this document unless otherwise stated.

### 5.1 Concatenation

A || B represents the concatenation of the fields A and B: content of A followed by content of B.

### 5.2 Hexadecimal numbers

(XY) denotes a hexadecimal number XY (i.e. with the Radix of 16) and each pair of characters is encoded in one octet.

## 6 Acronyms

---

For the purposes of this Standard, all acronyms from ECMA-385 apply. Additionally, the following acronyms apply.

A	Sender, as specified in ECMA-385
AES	Advanced Encryption Standard
B	Receiver, as specified in ECMA-385
$d_A$	Sender's private EC key
$d_B$	Recipient's private EC key
DataLen	Length of the UserData
EC	Elliptic Curve
ECDH	Elliptic Curve Diffie-Hellman
EncData	Encrypted data
G	The base point on EC
$ID_A$	Sender nfcid3
$ID_B$	Recipient nfcid3
$ID_R$	Any Recipient identification number (e.g. $ID_B$ )
$ID_S$	Any Sender identification number (e.g. $ID_A$ )
IV	Initial Value
K	Key
KDF	Key Derivation Function
KE	Encryption Key
KI	Integrity Key
MAC	Message Authentication Code
$Mac_A / Mac_B$	Integrity protection value of Sender/ Recipient
$MacTag_A$	Key confirmation tag from Sender
$MacTag_B$	Key confirmation tag from Recipient
MK	Master Key
NA / NB	Nonce generated by Sender/Recipient
NAA / NBB	Nonce generated by the pair of NFC-SEC entities
$Nonce_S$	Sender's nonce
$Nonce_R$	Recipient's nonce
PK	Public Key
$PK_R$	Recipient's Public Key
$PK_S$	Sender's Public Key
PRNG	Pseudo Random Number Generator
QA / QB	Compressed EC public key of Sender / Recipient
$Q_A / Q_B$	Decompressed EC public key of Sender / Recipient
RNG	Random Number Generator

SharedSecret	Shared secret
UserData	NFC-SEC User data
z	Unsigned integer representation of the Shared Secret
Z	Octet string representation of z

The acronyms used in Clauses 9 and 10 not listed above are formal parameters.

## 7 General

This Standard specifies mechanisms for the Shared Secret Service (SSE) and the Secure Channel Service (SCH) in ECMA-385.

To enable secure communication between NFC devices that do not share any common secret data ("keys") before they start communicating with each other, public key cryptography is used to establish a shared secret between these devices, and more specifically the Elliptic Curve Diffie-Hellman key exchange scheme. This shared secret is used to establish the SSE and the SCH.

## 8 NFC-SEC-01 Protocol Identifier (PID)

NFC-SEC-01 shall use the one octet protocol identifier PID with value 1.

## 9 NFC-SEC-01 Primitives

This clause specifies cryptographic primitives. Clauses 11 and 12 specify the actual use of these primitives.

Table 1 summarizes the features of NFC-SEC-01.

Table 1 – Summary of NFC-SEC-01 features

<b>Supported services</b>	SSE (see ECMA-385) SCH (see ECMA-385)
<b>Key agreement</b>	ECDH P-192
<b>KDF</b>	AES-XCBC-PRF-128
<b>Key confirmation</b>	AES-XCBC-MAC-96
<b>Data encryption</b>	AES128-CTR IV Init: AES-XCBC-PRF-128
<b>Data integrity</b>	AES-XCBC-MAC-96
<b>Sequence integrity</b>	SN (see ECMA-385)
<b>Encryption order</b>	Encryption (9.5) before MAC calculation (9.6)

### 9.1 Key agreement

Peer NFC-SEC entities shall agree on a shared secret using Key agreement mechanism 4 from ISO/IEC 11770-3 and the Elliptic Curves Diffie-Hellman primitives from IEEE 1363 as further specified below.

#### 9.1.1 Curve P-192

Curve P-192 as specified in FIPS 186-2 shall be used.

### 9.1.2 EC Key Pair Generation Primitive

The private key  $d$  shall be obtained from a random or pseudo-random process conforming to ISO/IEC 18031.

- a) Obtain the private key,  $d$ , from a random or pseudo-random process conforming to ISO/IEC 18031.
- b) Compute the public key,  $PK$ , as a point on EC,  $PK = dG$ .

### 9.1.3 EC Public key validation

The EC public key shall be validated as specified in *Public Key Validation* of ISO/IEC 15946-1.

### 9.1.4 ECDH secret value derivation Primitive

The ECDH primitive as specified in 7.2.1 *ECSVDP-DH* of IEEE 1363 shall output the 'valid' shared secret  $z$  and 'invalid' otherwise.

### 9.1.5 Random nonces

Each peer NFC-SEC entity should send fresh random nonces with the EC public key of the entity.

The nonces are used to provide more entropy to the keys derived from the shared secret ( $z$ ), and to facilitate the EC key pair management.

The correct generation of these nonces is under the responsibility of the entity.

The entity should guarantee that the nonces it generates have 96 bits of entropy valid for the duration of the protocol. The nonces used in an NFC-SEC transaction shall be cryptographically uncorrelated with the nonces from a previous transaction.

See ISO/IEC 18031 for further recommendations on random number generation.

## 9.2 Key Derivation Functions

Two Key Derivation Functions (KDF) are specified; one for the SSE and one for the SCH.

The KDFs shall use AES in XCBC-PRF-128 mode as specified in A.1.

For the following sections KDF is:

$$\text{KDF}(K, S) = \text{AES-XCBC-PRF-128}_K(S)$$

The random source (nonces + shared secret  $z$  obtained from 9.1.4) used for the SCH shall be different from the random source used for the SSE.

### 9.2.1 KDF for the SSE

The KDF for the SSE is:

$$\text{MK}_{\text{SSE}} = \text{KDF-SSE}(\text{Nonce}_S, \text{Nonce}_R, \text{SharedSecret}, \text{ID}_S, \text{ID}_R)$$

Detail of the KDF-SSE function:

$$S = (\text{Nonce}_S [0..63] \parallel \text{Nonce}_R [0..63])$$

$$\text{SKEYSEED} = \text{KDF}(S, \text{SharedSecret})$$

$$\text{MK}_{\text{SSE}} = \text{KDF}(\text{SKEYSEED}, S \parallel \text{ID}_S \parallel \text{ID}_R \parallel (01))$$

### 9.2.2 KDF for the SCH

The KDF for the SCH is:

$$\{\text{MK}_{\text{SCH}}, \text{KE}_{\text{SCH}}, \text{KI}_{\text{SCH}}\} = \text{KDF-SCH}(\text{Nonce}_S, \text{Nonce}_R, \text{SharedSecret}, \text{ID}_S, \text{ID}_R)$$

Detail of the KDF-SCH function:

$$S = (\text{Nonce}_S [0..63] \parallel \text{Nonce}_R [0..63])$$

$$\text{SKEYSEED} = \text{KDF}(S, \text{SharedSecret})$$

$$\text{MK}_{\text{SCH}} = \text{KDF}(\text{SKEYSEED}, S \parallel \text{ID}_S \parallel \text{ID}_R \parallel (01))$$

$$KE_{SCH} = \text{KDF}(\text{SKEYSEED}, MK_{SCH} \parallel S \parallel ID_S \parallel ID_R \parallel (02))$$

$$KI_{SCH} = \text{KDF}(\text{SKEYSEED}, KE_{SCH} \parallel S \parallel ID_S \parallel ID_R \parallel (03))$$

### 9.3 Key Usage

Each derived key  $MK_{SCH}$ ,  $KE_{SCH}$ ,  $KI_{SCH}$  and  $MK_{SSE}$  should be used only for the purpose specified in Table 2.

The Keys  $MK_{SCH}$ ,  $KE_{SCH}$ ,  $KI_{SCH}$  and  $MK_{SSE}$  shall be different for each NFC-SEC transaction.

Table 2 – Key usage

Key	Key description	Key usage
$MK_{SCH}$	Master Key for SCH	Key Verification for the Secure Channel Keys
$KE_{SCH}$	Encryption Key for SCH	Encryption of data packets sent through SCH
$KI_{SCH}$	Integrity protection Key for SCH	Integrity protection of data packets sent through SCH
$MK_{SSE}$	Master Key for SSE	Master Key for SSE used as Shared secret to be passed to the upper layer and as Key Verification

### 9.4 Key Confirmation

When a key is derived using one of the KDF processes described in 9.2 both NFC-SEC entities check that they indeed have the same key. Each entity shall generate a key confirmation tag as specified in 9.4.1 and shall send it to the peer entity. Entities shall verify the key confirmation tag upon reception as specified in 9.4.2.

This key confirmation mechanism is according to *9 Key Confirmation* of ISO/IEC 11770-3.

The MAC used for Key Confirmation (MacTag) shall be AES in XCBC-MAC-96 mode as specified in A.2.

#### 9.4.1 Key confirmation tag generation

MacTag, the Key confirmation tag, equals

MAC-KC (K, MsgID, IDS, IDR, PKS, PKR) and shall be calculated using  
 AES-XCBC-MAC-96<sub>K</sub> (MsgID || ID<sub>S</sub> || ID<sub>R</sub> || PK<sub>S</sub> || PK<sub>R</sub>), specified in Annex A.2, with key K.

#### 9.4.2 Key confirmation tag verification

'status', the return value of

MAC-KC-VER (K, MsgID, IDS, IDR, PKS, PKR, MacTag') is true  
 if MacTag' equals MAC-KC (K, MsgID, ID<sub>S</sub>, ID<sub>R</sub>, PK<sub>S</sub>, PK<sub>R</sub>)

### 9.5 Data Encryption

The data encryption algorithm used is AES as specified in *5.1 AES* of ISO/IEC 18033-3.

The data encryption mode shall be CTR mode as specified in *10 Counter (CTR) Mode* of ISO/IEC 10116.

#### 9.5.1 Initial value of counter (IV)

To avoid having to send the initial value of the counter, it shall be computed by both entities from the nonces.

IV, the initial value of the counter, equals

MAC-IV (MK, KI, NonceS, NonceR) and shall be calculated using  
 AES-XCBC-PRF-128MK (KI || NonceS || NonceR || (04)), specified in Annex A.1, with key MK.

### 9.5.2 Encryption

The data shall be encrypted using the Encryption Key KE as specified in 10.2 *Encryption of ISO/IEC 10116*:

$$\text{EncData} = \text{ENC}_{\text{KE}} (\text{Data})$$

Since the mode is CTR, no padding of the data shall be applied.

### 9.5.3 Decryption

The encrypted data shall be decrypted using the Encryption Key KE as specified in 10.3 *Decryption of ISO/IEC 10116*:

$$\text{Data}' = \text{DEC}_{\text{KE}} (\text{EncData})$$

## 9.6 Data Integrity

Integrity of all data transferred on the SCH shall be preserved through a MAC.

The MAC used for Data Integrity shall be AES in XCBC-MAC-96 mode as specified in A.2.

### 9.6.1 Protect data integrity

Mac, the Message Authentication Code, equals MAC-DI (KI, SN, DataLen, EncData) and shall be calculated using AES-XCBC-MAC-96<sub>KI</sub> (SN || DataLen || EncData), specified in Annex A.2, with key KI.

### 9.6.2 Check data integrity

'status', the return value of MAC-DI-VER (KI, SN, DataLen, EncData, Mac') is true if Mac' equals MAC-DI (KI, SN || DataLen || EncData)

## 9.7 Message Sequence Integrity

Message sequence integrity shall be handled as specified in 12.3 of ECMA-385.

The SNV value shall be in the range of 0 to  $2^{24} - 1$ ; with the initial value of 0.

Entities shall terminate the SCH when the SNV has reached  $2^{24} - 1$ .

# 10 Data Conversions

---

## 10.1 Integer-to-Octet-String Conversion

Input: A non-negative integer  $x$ , and the intended length  $k$  of the octet string satisfying:  $2^{8k} > x$ .

Output: An octet string  $M$  of length  $k$  octets.

Let  $M_1, M_2, \dots, M_k$  be the octets of  $M$  from leftmost to rightmost.

The octets of  $M$  shall satisfy:

$$x = \sum_{i=1}^k 2^{8(k-i)} M_i$$

## 10.2 Octet-String-to-Integer Conversion

Input: An octet string  $M$  of length  $k$  octets.

Output: An integer  $x$ .

Let  $M_1, M_2, \dots, M_k$  be the octets of  $M$  from leftmost to rightmost.

$M$  shall be converted to an integer  $x$  satisfying:

$$x = \sum_{i=1}^k 2^{8(k-i)} M_i$$

### 10.3 Point-to-Octet-String Conversion

The point on the EC shall be converted to an octet string in the following way:

Input: An elliptic curve point  $P = (x_P, y_P)$ .

Output: An octet string PO with the y-coordinate in the leftmost octet and the x-coordinate in the remainder of the octet string.

1. Convert the field element  $x_P$  to an octet string X as specified in 10.1.
2. Compute the bit  $\tilde{y}_P$  as specified in 6.6: *Elliptic curve point / octet string conversion: EC2OSPE and OS2ECPE* of ISO/IEC 15946-1.
3. Assign the value (02) to the single octet PC if  $\tilde{y}_P$  is 0, or the value (03) if  $\tilde{y}_P$  is 1
4. The result is the octet string  $PO = PC \parallel X$ .

### 10.4 Octet-String-to-Point Conversion

The octet string shall be converted to a point on the EC in the following way:

Input: An octet string PO, with the y-coordinate in the leftmost octet and the x-coordinate in the remainder of the octet string

Output: An elliptic curve point  $P = (x_P, y_P)$ .

1. Parse PO as follows:  $PO = PC \parallel X$ , where PC is a single octet, and X is an octet string of length k octets.
2. Convert X to a field element  $x_P$  as specified in 10.2.
3. Verify that PC is either (02) or (03). It is an error if this is not the case.
4. Set the bit  $\tilde{y}_P$  to be equal to 0 if  $PC = (02)$ , or 1 if  $PC = (03)$ .
5. Convert  $(x_P, \tilde{y}_P)$  to an elliptic curve point  $(x_P, y_P)$  as specified in 6.6: *Elliptic curve point / octet string conversion: EC2OSPE and OS2ECPE* of ISO/IEC 15946-1.
6. The result is  $P = (x_P, y_P)$ .

## 11 SSE and SCH service invocation

SSE and SCH are invoked by establishment of a shared secret between two NFC-SEC entities using the key agreement and key confirmation protocol specified in ECMA-385, in the way illustrated in Figure 1 and further specified in this clause.

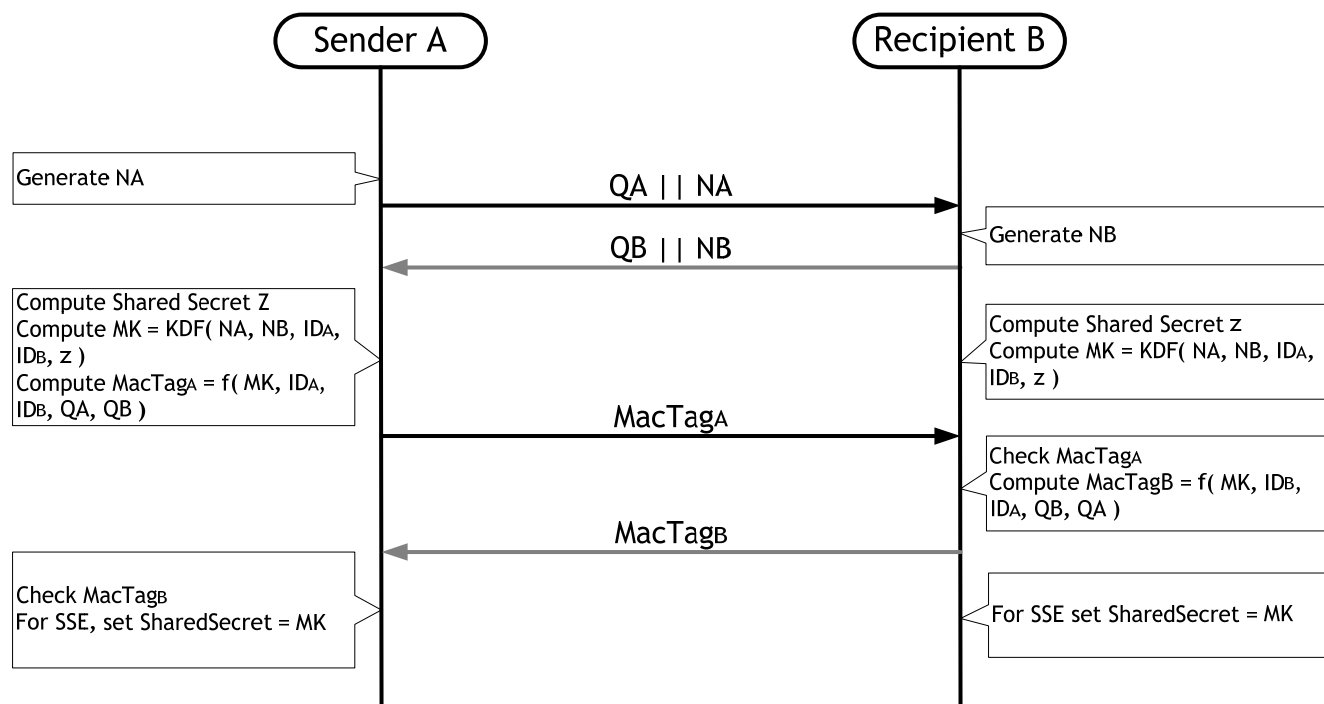

Figure 1 – Key agreement and confirmation overview

### 11.1 Pre-requisites

Before starting the service, the followings shall be available on each NFC-SEC entity:

- Its own EC public and private key, generated as specified in 9.1.2.

*NOTE*

*It is outside the scope of this standard when (and at which frequency) this EC key pair is generated.*

- Its own nfcid3 and the other NFC-SEC entity's nfcid3 as specified in ECMA-340.

## 11.2 Key Agreement

Sender (A)	PDU Communication direction is indicated by arrow character Payload is between ( )	Recipient (B)
Generate nonce NA		
Compress $Q_A$		
Send to B	A→B: ACT_REQ ( $Q_A    NA$ )	
		Generate nonce NB
		Compress $Q_B$
	A←B: ACT_RES ( $Q_B    NB$ )	Send to A
Reconstruct $Q_B'$ from $Q_B'$		Reconstruct $Q_A'$ from $Q_A'$
Check $Q_B'$		Check $Q_A'$
Compute shared secret: Z		Compute shared secret: Z

### 11.2.1 Sender (A) Transformation

1. Generate a nonce NA as specified in 9.1.5.
2. Ensure  $Q_A$  equals the octet string of  $Q_A$  as specified in 10.3.
3. Send  $Q_A || NA$  as the payload of the ACT\_REQ PDU.
4. Receive  $Q_B' || NB'$  from the payload of the ACT\_RES PDU.
5. Reconstruct  $Q_B'$  from  $Q_B'$  as specified in 10.4.
  - a) If the public keys have already been received, the previously calculated and stored value  $Q_B'$  may be reused and the following steps may be skipped.
6. Verify that  $Q_B'$  is a valid key for the EC parameters as specified in 9.1.3. If it is invalid, then set the 'PDU content valid' to false in the Protocol Machine and skip step 7 and 8.
7. Use the Diffie-Hellman primitive in 9.1.4. If its output  $z$  is 'invalid' then set the 'PDU content valid' to false in the Protocol Machine and skip step 8.
8. Convert  $z$  to octet string  $Z$  using the convention specified in 10.1.

### 11.2.2 Recipient (B) Transformation

1. Receive  $Q_A' || NA'$  from the payload of the ACT\_REQ PDU
2. Generate a nonce NB as specified in 9.1.5.
3. Ensure  $Q_B$  equals the octet string of  $Q_B$  as specified in 10.3.
4. Send  $Q_B || NB$  as the payload of the ACT\_RES PDU.
5. Reconstruct  $Q_A'$  from  $Q_A'$  as specified in 10.4.
  - a) If the public keys have already been received, the previously calculated and stored value  $Q_A'$  may be reused and the following steps may be skipped.
6. Verify that  $Q_A'$  is a valid key for the EC parameters as specified in 9.1.3. If it is invalid, then set the 'PDU content valid' to false in the Protocol Machine and skip step 7 and 8.
7. Use the Diffie-Hellman primitive in 9.1.4. If its output  $z$  is 'invalid', then set the 'PDU content valid' to false in the Protocol Machine and skip step 8.

8. Convert  $z$  to octet string  $Z$  using the convention specified in 10.1.

## 11.3 Key Derivation

### 11.3.1 Sender (A) Transformation

For the SSE service, derive  $MK_{SSE} = KDF-SSE(NA, NB', Z, ID_A, ID_B)$  as specified in 9.2.1.

For the SCH service, derive  $\{MK_{SCH}, KE_{SCH}, KI_{SCH}\} = KDF-SCH(NA, NB', Z, ID_A, ID_B)$  as specified in 9.2.2.

### 11.3.2 Recipient (B) Transformation

For the SSE service, derive  $MK_{SSE} = KDF-SSE(NA', NB, Z, ID_A, ID_B)$  as specified in 9.2.1.

For the SCH service, derive  $\{MK_{SCH}, KE_{SCH}, KI_{SCH}\} = KDF-SCH(NA', NB, Z, ID_A, ID_B)$  as specified in 9.2.2.

## 11.4 Key Confirmation

Sender (A)	PDU	Recipient (B)
	Communication direction is indicated by arrow character Payload is between ()	
Compute key confirmation tag: MacTag <sub>A</sub> (MK)		
Send to B	A→B: VFY_REQ (MacTag <sub>A</sub> )	
		Check key confirmation tag received from A: MacTag <sub>A</sub> '(MK)
		Compute key confirmation tag: MacTag <sub>B</sub> (MK)
	A←B: VFY_RES (MacTag <sub>B</sub> )	Send to A
Check key confirmation tag received from B: MacTag <sub>B</sub> '(MK)		
For SSE, set the Shared Secret Value to MK		For SSE, set the Shared Secret Value to MK

### 11.4.1 Sender (A) Transformation

1. Compute the key confirmation tag from A to B  $MacTag_A = MAC-KC(MK, (03), ID_A, ID_B, QA, QB')$  as specified in 9.4.1.
2. Send  $MacTag_A$  as the payload of the VFY\_REQ PDU.
3. Receive  $MacTag_B'$  from the payload of the VFY\_RES PDU.
4. Check the key confirmation tag from B to A. Set 'PDU content valid' in the Protocol Machine to the output of  $MAC-KC-VER(MK, (02), ID_B, ID_A, QB', QA, MacTag_B')$  as specified in 9.4.2. If it is 'invalid' then skip step 5.
5. For the SSE service, set  $SharedSecret = MK_{SSE}$ .

### 11.4.2 Recipient (B) Transformation

1. Receive  $MacTag_A'$  from the payload of the VFY\_REQ PDU.
2. Check the key confirmation tag from A to B. Set 'PDU content valid' in the Protocol Machine to the output of  $MAC-KC-VER(MK, (03), ID_A, ID_B, QA', QB, MacTag_A')$  as specified in 9.4.2. If it is 'invalid' then skip step 3, 4 and 5.

3. Compute the key confirmation tag from B to A  $MacTagB = MAC-KC(MK, (02), IDB, IDA, QB, QA')$  as specified in 9.4.1.
4. Send  $MacTagB$  as the payload of the  $VFY\_RES$  PDU .
5. For the SSE service, set  $SharedSecret = MK_{SSE}$ .

## 12 SCH data exchange

After invocation of the SCH as specified in 11, the data exchange between two NFC-SEC entities uses the protocol specified in ECMA-385 as illustrated in Figure 2 and further specified in this clause.

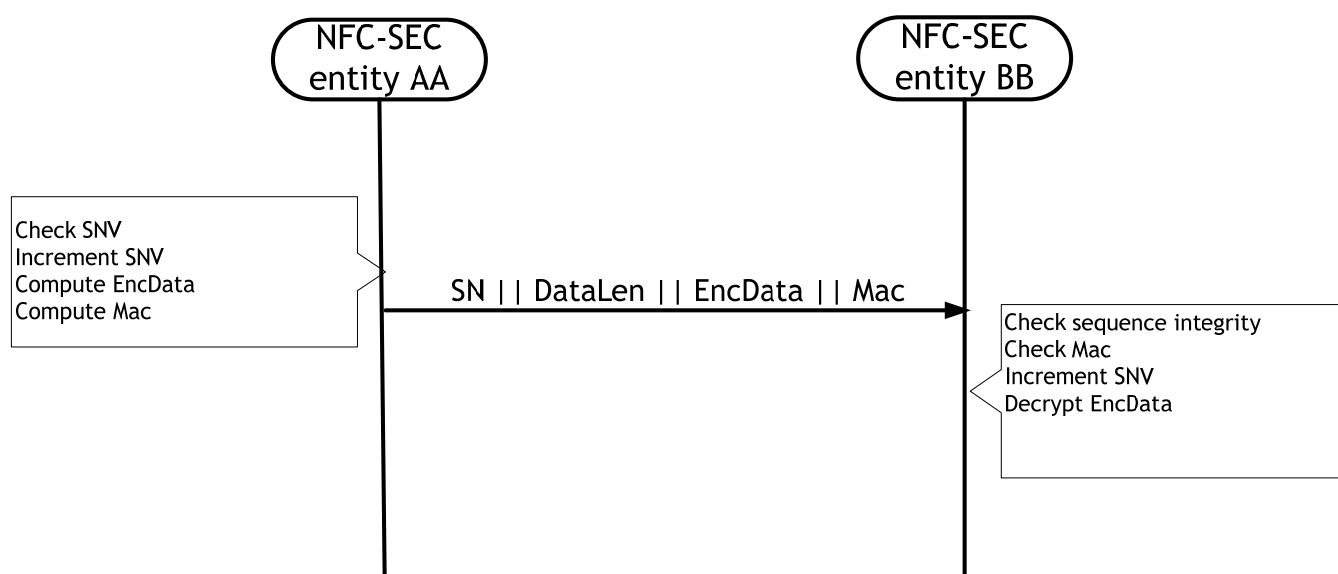

Figure 2 – SCH: protocol overview

### 12.1 Preparation

NFC-SEC entity (AA and BB) shall perform the following preparatory steps:

1. Generate the initial value of the CTR counter  $IV = MAC-IV (MK, KI, NAA, NBB)$  as specified in 9.5.1.
2. Initialise the Sequence Number variable (SNV) as specified in 9.7.

## 12.2 Data Exchange

Sending peer entity AA (A or B)	PDU transmitted Communication direction is indicated by arrow character Payload is between ()	Receiving peer entity BB (A or B)
<ul style="list-style-type: none"> <li>• Receive UserData from SendData SDU</li> <li>• Check SNV</li> <li>• Increment SNV</li> <li>• Encrypt Data: EncData</li> <li>• Apply MAC: Mac</li> </ul>		
	ENC (SNV    DataLen    EncData    Mac)	
		Receiving: <ul style="list-style-type: none"> <li>• Check sequence integrity</li> <li>• Check data integrity</li> <li>• Decrypt data</li> </ul>

### 12.2.1 Send

To send data, the sending NFC-SEC peer entity AA (A or B) shall perform the following steps:

1. Receive UserData from the SendData SDU.
2. If  $SNV = 2^{24}-1$ , then set the 'PDU content valid' to false in the Protocol Machine, otherwise proceed to the next step.
3. Increment the SNV as specified in 12.3 of ECMA-385.
4. Compute the encrypted data EncData from UserData as specified in 9.5.2.
5. Compute the MAC Mac on SNV || DataLen || EncData as specified in 9.6.1.
6. Send SNV || DataLen || EncData || Mac as the payload of the ENC PDU.

### 12.2.2 Receive

To receive data, the receiving NFC-SEC peer entity BB (A or B) shall perform the following steps:

1. Receive SNV || DataLen || EncData || Mac from the payload of the ENC PDU.
2. If  $SNV = 2^{24}-1$ , then set the 'PDU content valid' to false in the Protocol Machine, otherwise proceed to the next step.
3. Check the sequence integrity as specified in 12.3 of ECMA-385.
4. Check the data integrity of SNV || DataLen || EncData as specified in 9.6.2. If it is invalid, then set the 'PDU content valid' to false in the Protocol Machine, otherwise proceed to the next step.
5. Compute the decrypted data UserData from EncData as specified in 9.5.3.

## Annex A (normative)

### AES-XCBC-PRF-128 and AES-XCBC-MAC-96 algorithms

#### A.1 AES-XCBC-PRF-128

The AES-XCBC-PRF-128 algorithm is a variant of the basic CBC-MAC with obligatory “10\* padding”, which makes it secure for messages of arbitrary length.

The encryption operations must be accomplished using AES with a 128-bit key.

Given a 128-bit secret key K, AES-XCBC-PRF-128 is calculated as follows for a message M that consists of n blocks, M[1] ... M[n], in which the block size of blocks M[1] ... M[n-1] is 128 bits and the block size of block M[n] is between 1 and 128 bits:

1. Derive 3 128-bit keys (K1, K2 and K3) from the 128-bit secret key K, as follows:  
K1 = (01) encrypted with Key K  
K2 = (02) encrypted with Key K  
K3 = (03) encrypted with Key K
2. Define E[0] = 0x00000000000000000000000000000000
3. For each block M[i], where i = 1 ... n-1:  
XOR M[i] with E[i-1],  
then encrypt the result with Key K1, yielding E[i].
4. For block M[n]:
  - a. If the block size of M[n] is 128 bits:  
XOR M[n] with E[n-1] and Key K2,  
then encrypt the result with Key K1, yielding E[n].
  - b. If the block size of M[n] is less than 128 bits:
    - i. Pad M[n] with a single “1” bit, followed by the number of “0” bits (possibly none) required to increase M[n]’s block size to 128 bits (this is the “10\* padding”)
    - ii. XOR M[n] with E[n-1] and Key K3,  
then encrypt the result with Key K1, yielding E[n].
5. The output is the last 128 bits block E[n].

#### A.2 AES-XCBC-MAC-96

The AES-XCBC-MAC-96 algorithm is the AES-XCBC-PRF-128 algorithm, followed by a truncation step:

1. Take the first 96 bits of E[n].

Upon sending, the truncated value is stored within the authenticator field (Mac).

Upon receipt, the entire 128-bit value is computed and the first 96 bits are compared to the value stored in the authenticator field (Mac).



## Annex B (normative)

### NFC-SEC-01 fields sizes

Table B.1 – NFC-SEC-01 fields sizes

<b>Field</b>	<b>Size</b>
NA	96 bits
NB	96 bits
d <sub>A</sub>	192 bits
d <sub>B</sub>	192 bits
DataLen	24 bits
Q <sub>A</sub>	384 bits
Q <sub>B</sub>	384 bits
QA	200 bits
QB	200 bits
Z	192 bits
MK	128 bits
KE	128 bits
KI	128 bits
MacTag <sub>A</sub>	96 bits
MacTag <sub>B</sub>	96 bits
IV	128 bits
SNV	24 bits
Mac	96 bits



## Annex C (informative)

### Informative references

RFC 4303	IP Encapsulating Security Payload (ESP)
RFC 4306	Internet Key Exchange (IKEv2) Protocol
RFC 4434	The AES-XCBC-PRF-128 Algorithm for the Internet Key Exchange Protocol (IKE)
RFC 3566	The AES-XCBC-MAC-96 Algorithm and Its Use With IPsec

The AES-XCBC-PRF-128 algorithm is specified in RFC 4434 (IPSEC v2).

The AES-XCBC-MAC-96 algorithm is specified in RFC 3566 (IPSEC v2).

The KDF is specified in RFC 4306 (IPSEC v2).

The ENC then MAC protection mechanism is specified in RFC 4303 (IPSEC v2).



