

ECMA

Standardizing Information and Communication Systems

**Private Integrated Services Network
(PISN) -
Specification, Functional Model and
Information Flows -
Call Priority Interruption and Call
Priority Interruption Protection
Supplementary Services**

ECMA

Standardizing Information and Communication Systems

**Private Integrated Services Network
(PISN) -
Specification, Functional Model and
Information Flows -
Call Priority Interruption and Call
Priority Interruption Protection
Supplementary Services**

(CPI(P)SD)

Brief History

This Standard is one of a series of ECMA Standards defining services and signalling procedures applicable to Private Integrated Services Networks (PISNs). The series uses the ISDN concepts as developed by ITU-T and conforms to the framework of International Standards for Open Systems Interconnection as defined by ISO/IEC. It has been produced under ETSI work item DES/ECMA-00155.

This particular Standard specifies the Call Priority Interruption (CPI) and Call Priority Interruption Protection (CPIP) supplementary services.

This Standard is based upon the practical experience of ECMA member companies and the results of their active and continuous participation in the work of ISO/IEC JTC1, ITU-T, ETSI and other international and national standardization bodies. It represents a pragmatic and widely based consensus.

There are currently no equivalent services specified by ITU-T or ETSI for public ISDN.

This ECMA Standard is contributed to ISO/IEC JTC1 under the terms of the fast-track procedure, for adoption as an ISO/IEC International Standard.

This ECMA Standard has been adopted by the General Assembly in September 1997.

Table of contents

1 Scope	1
2 Conformance	1
3 References (normative)	1
4 Definitions	2
4.1 External definitions	2
4.2 Additional network feature	2
4.3 Call, Basic call	2
4.4 Call Priority Interruption Capability Level (CPICL)	2
4.5 Call Priority Interruption Protection Level (CPIPL)	2
4.6 Established call	3
4.7 Impending priority interruption state	3
4.8 Impending priority interruption warning notification	3
4.9 Non-priority call	3
4.10 Priority call	3
4.11 Protected call	3
4.12 Served user	3
4.13 Time to priority interruption	3
4.14 Unprotected call	3
5 List of acronyms	3
6 SS-CPI stage 1 specification	4
6.1 Description	4
6.1.1 General description	4
6.1.2 Qualifications on applicability to telecommunication services	4
6.2 Procedure	4
6.2.1 Provision/withdrawal	4
6.2.2 Normal procedures	4
6.2.3 Exceptional procedures	6
6.3 Interaction with other supplementary services and ANFs	6
6.3.1 Calling Name Identification Presentation (SS-CNIP)	6
6.3.2 Connected Name Identification Presentation (SS-CONP)	6
6.3.3 Completion of Call to Busy Subscriber (SS-CCBS)	6
6.3.4 Completion of Call on No Reply (SS-CCNR)	6
6.3.5 Call Transfer (SS-CT)	6
6.3.6 Call Forwarding Unconditional (SS-CFU)	6
6.3.7 Call Forwarding Busy (SS-CFB)	6
6.3.8 Call Forwarding No Reply (SS-CFNR)	6
6.3.9 Call Deflection (SS-CD)	7
6.3.10 Path Replacement (ANF-PR)	7

6.3.11 Call Offer (SS-CO)	7
6.3.12 Call Intrusion (SS-CI)	7
6.3.13 Do not Disturb (SS-DND)	7
6.3.14 Do not Disturb Override (SS-DNDO)	7
6.3.15 Advice of Charge (SS-AOC)	7
6.3.16 Recall (SS-RE)	7
6.3.17 Call Interception (ANF-CINT)	7
6.3.18 Transit Counter (ANF-TC)	7
6.3.19 Cordless Terminal Location Registration (SS-CTRL)	7
6.3.20 Cordless Terminal Incoming Call (ANF-CTMI)	7
6.3.21 Cordless Terminal Outgoing Call (ANF-CTMO)	7
6.3.22 Authentication of a CTM User (SS-CTAU)	7
6.3.23 Authentication of the PISN (SS-CTAN)	7
6.3.24 Message Waiting Indication (SS-MWI)	7
6.3.25 Common Information (ANF-CMN)	7
6.3.26 Call Priority Interruption Protection (SS-CPIP)	7
6.4 Interworking considerations	8
6.5 Overall SDL	8
7 SS-CPIP stage 1 specification	12
7.1 Description	12
7.1.1 General description	12
7.1.2 Qualifications on applicability to telecommunication services	12
7.2 Procedure	12
7.2.1 Provision/withdrawal	12
7.2.2 Normal procedures	12
7.2.3 Exceptional procedures	13
7.3 Interaction with other supplementary services and ANFs	13
7.3.1 Calling Name Identification Presentation (SS-CNIP)	13
7.3.2 Connected Name Identification Presentation (SS-CONP)	13
7.3.3 Completion of Call to Busy Subscriber (SS-CCBS)	13
7.3.4 Completion of Call on No Reply (SS-CCNR)	13
7.3.5 Call Transfer (SS-CT)	13
7.3.6 Call Forwarding Unconditional (SS-CFU)	13
7.3.7 Call Forwarding Busy (SS-CFB)	13
7.3.8 Call Forwarding No Reply (SS-CFNR)	13
7.3.9 Call Deflection (SS-CD)	13
7.3.10 Path Replacement (ANF-PR)	13
7.3.11 Call Offer (SS-CO)	13
7.3.12 Call Intrusion (SS-CI)	13
7.3.13 Do not Disturb (SS-DND)	13
7.3.14 Do not Disturb Override (SS-DNDO)	14
7.3.15 Advice of Charge (SS-AOC)	14
7.3.16 Recall (SS-RE)	14

7.3.17 Call Interception (ANF-CINT)	14
7.3.18 Transit Counter (ANF-TC)	14
7.3.19 Cordless Terminal Location Registration (SS-CTLR)	14
7.3.20 Cordless Terminal Incoming Call (ANF-CTMI)	14
7.3.21 Cordless Terminal Outgoing Call (ANF-CTMO)	14
7.3.22 Authentication of a CTM User (SS-CTAU)	14
7.3.23 Authentication of the PISN (SS-CTAN)	14
7.3.24 Message Waiting Indication (SS-MWI)	14
7.3.25 Common Information (ANF-CMN)	14
7.3.26 Call Priority Interruption (SS-CPI)	14
7.4 Interworking considerations	14
7.5 Overall SDL	14
8 SS-CPI stage 2 specification	16
8.1 Functional model	16
8.1.1 Functional model description	16
8.1.2 Description of Functional Entities	16
8.1.3 Relationship of functional model to basic call functional model	17
8.2 Information flows	18
8.2.1 Definition of information flows	18
8.2.2 Relationship of information flows to basic call information flows	19
8.2.3 Information flow sequences	19
8.3 Functional Entity actions	23
8.3.1 Actions of FE1	23
8.3.2 Actions of FE2	23
8.3.3 Actions of FE3	23
8.3.4 Actions of FE4	23
8.3.5 Actions of FE5	24
8.4 Functional entity behaviour	24
8.4.1 Behaviour of FE1	24
8.4.2 Behaviour of FE2	26
8.4.3 Behaviour of FE3	27
8.4.4 Behaviour of FE4	29
8.4.5 Behaviour of FE5	30
8.5 Allocation of Functional Entities to physical equipment	31
8.6 Interworking considerations	31
9 SS-CPIP stage 2 specification	31
9.1 Functional model	31
9.1.1 Functional model description	31
9.1.2 Description of Functional Entities	32
9.1.3 Relationship of functional model to basic call functional model	33
9.2 Information flows	33
9.2.1 Definition of information flows	33

9.2.2 Relationship of information flows to basic call information flows	35
9.2.3 Information flow sequences	35
9.3 Functional Entity actions	38
9.3.1 Actions of FE1	38
9.3.2 Actions of FE2	38
9.3.3 Actions of FE3	39
9.3.4 Actions of FE4	39
9.3.5 Actions of FE5	39
9.4 Functional entity behaviour	39
9.4.1 Behaviour of FE1	39
9.4.2 Behaviour of FE2	41
9.4.3 Behaviour of FE3	42
9.4.4 Behaviour of FE4	43
9.4.5 Behaviour of FE5	44
9.5 Allocation of Functional Entities to physical equipment	45
9.6 Interworking considerations	45

1 Scope

This Standard specifies the Supplementary Services Call Priority Interruption (SS-CPI) and Call Priority Interruption Protection (SS-CPIP), which are applicable to various basic services supported by Private Integrated Services Networks (PISN). Basic services are specified in ECMA-142.

NOTE 1

This edition of this Standard does not apply to the circuit-mode Multiple Rate Bearer Service.

SS-CPI is a supplementary service that allows a call request for a priority call to proceed successfully in the case that there is no user information channel available. This is accomplished by force releasing an established call of lower priority.

SS-CPIP is a supplementary service that allows for the protection of calls against interruption from other, priority, calls.

SS-CPI and SS-CPIP are described separately because SS-CPI is a service used by a calling user, and SS-CPIP is a service used by either a calling user or a called user.

Supplementary service specifications are produced in three stages, according to the method described in ETS 300 387. This Standard contains the stage 1 and stage 2 specifications of SS-CPI. The stage 1 specification (clause 6) specifies the general feature principles and capabilities. The stage 2 specification (clause 7) identifies the Functional Entities involved in the supplementary service and the information flows between them.

2 Conformance

In order to conform to this Standard, a stage 3 standard shall specify signalling protocols and equipment behaviour that are capable of being used in a PISN which supports the supplementary service specified in this Standard. This means that, to claim conformance, a stage 3 standard is required to be adequate for the support of those aspects of clause 6 (stage 1) and clause 7 (stage 2) which are relevant to the interface or equipment to which the stage 3 standard applies.

3 References (normative)

The following standards contain provisions which, through reference in this text, constitute provisions of this Standard. All standards are subject to revision, and parties to agreements based on this Standard are encouraged to investigate the possibility of applying the most recent editions of the standards indicated below.

In the case of references to ECMA standards that are aligned with ISO/IEC International Standards, the number of the appropriate ISO/IEC International Standard is given in brackets after the ECMA reference.

ECMA-142	Private Integrated Services Network - Circuit-mode 64 kbit/s Bearer Services - Service Description, Functional Capabilities and Information Flows (International Standard ISO/IEC 11574)
ECMA-173	Private Integrated Services Network - Specification, Functional Model and Information Flows - Call Diversion Supplementary Services (International Standard ISO/IEC 13872)
ECMA-175	Private Integrated Services Network - Specification, Functional Model and Information Flows - Path Replacement Additional Network Feature (International Standard ISO/IEC 13863)
ECMA-177	Private Integrated Services Network - Specification, Functional Model and Information Flows - Call Transfer Supplementary Service (International Standard ISO/IEC 13865)
ECMA-185	Private Integrated Services Network - Specification, Functional Model and Information Flows - Call Completion Supplementary Services (International Standard ISO/IEC 13866)
ECMA-220	Private Integrated Services Network - Specification, Functional Model and Information Flows - Call Interception Additional Network Feature (International Standard ISO/IEC 15053)
ISO/IEC 11579-1	Information technology - Telecommunications and information exchange between systems - Private Integrated Services Network - Part 1: Reference configuration for PISN Exchanges (PINX)

ETS 300 387	Private Telecommunication Network (PTN); Method for the specification of basic and supplementary services (1994)
ETS 300 694	Private Integrated Services Network (PISN); Cordless Terminal Mobility (CTM); Call handling additional network features; Service description (1996)
ITU-T Rec. I.112	Vocabulary of terms for ISDNs (1993)
ITU-T Rec. I.210	Principles of telecommunication services supported by an ISDN and the means to describe them (1993)
ITU-T Rec. Z.100	Specification and description language (1993)

4 Definitions

For the purposes of this Standard, the following definitions apply.

4.1 External definitions

This Standard uses the following terms defined in other documents:

- Basic service (ITU-T Rec. I.210)
- Private Integrated Services Network (PISN) (ISO/IEC 11579-1)
- Private Integrated Services Network Exchange (PINX) (ISO/IEC 11579-1)
- Service (ITU-T Rec. I.112)
- Signalling (ITU-T Rec. I.112)
- Supplementary Service (ITU-T Rec. I.210)
- User (ECMA-142)

This Standard refers to the following basic call Functional Entities (FE) defined in ECMA-142:

- Call Control (CC)
- Call Control Agent (CCA)

This Standard refers to the following basic call inter-FE relationships defined in ECMA-142:

- r1
- r2
- r3

This Standard refers to the following basic call information flows defined in ECMA-142:

- DISCONNECT request/indication
- RELEASE request/indication
- SETUP request/indication

4.2 Additional network feature

A capability, over and above that of a basic service, provided by a PISN, but not directly to a PISN user.

4.3 Call, Basic call

An instance of the use of a basic service.

4.4 Call Priority Interruption Capability Level (CPICL)

A parameter indicating the priority of a call.

4.5 Call Priority Interruption Protection Level (CPIPL)

A parameter indicating a level of protection of a call against interruption from other calls.

4.6 Established call

The active call that is selected for interruption.

4.7 Impending priority interruption state

The condition of an established call and a priority call after provision of an Impending priority interruption warning notification and before the release of the established call.

4.8 Impending priority interruption warning notification

A notification provided before the release of the established call.

4.9 Non-priority call

A call that has not been assigned a CPICL value.

4.10 Priority call

A call that has a CPICL value greater than zero.

NOTE 2

A priority call may also be a protected call.

4.11 Protected call

A call that has a CPIPL value greater than zero.

NOTE 3

A protected call may also be a priority call.

4.12 Served user

The user who requests SS-CPI and/or SS-CPIP.

4.13 Time to priority interruption

The duration of the impending priority interruption state.

4.14 Unprotected call

A call which has not been assigned a CPIPL value or has a CPIPL value equal to zero.

5 List of acronyms

ANF	Additional Network Feature
AOC	Advice Of Charge
CC	Call Control (Functional Entity)
CCA	Call Control Agent (Functional Entity)
CCBS	Call Completion to Busy Subscriber
CCNR	Call Completion on No Reply
CD	Call Deflection
CFB	Call Forwarding Busy
CFNR	Call Forwarding No Reply
CFU	Call Forwarding Unconditional
CI	Call Intrusion
CICL	Call Intrusion Capability Level
CINT	Call INTerception
CLIP	Calling Line Identification Presentation
CLIR	Calling/Connected Line Identification Restriction
CMN	CoMmoN Information
CNIP	Calling Name Identification Presentation
CNIR	Calling/Connected Name Identification Restriction
CO	Call Offer
COLP	Connected Line Identification Presentation
CONP	Connected Name Identification Presentation
CPI	Call Priority Interruption

CPICL	Call Priority Interruption Capability Level
CPIP	Call Priority Interruption Protection
CPIPL	Call Priority Interruption Protection Level
CT	Call Transfer
CTAU	Cordless Terminal AUthentication
CTLR	Cordless Terminal Location Registration
CTMI	Cordless Terminal Mobility Incoming call
CTMO	Cordless Terminal Mobility Outgoing call
DND	Do Not Disturb
DNDO	Do Not Disturb Override
FE	Functional Entity
ISDN	Integrated Services Digital Network
MWI	Message Waiting Indication
PINX	Private Integrated Services Network Exchange
PISN	Private Integrated Services Network
PR	Path Replacement
RE	REcall
SDL	Specification and Description Language
SS	Supplementary Service
TC	Transit Counter
TE	Terminal Equipment

6 SS-CPI stage 1 specification

6.1 Description

6.1.1 General description

Call Priority Interruption (SS-CPI) is a supplementary service that allows a call request for a priority call to proceed successfully in the case that there is no user information channel available.

A priority interruption only occurs if the served user has a higher Call Priority Interruption Capability Level (CPICL) than the Call Priority Interruption Protection Level (CPIPL) of at least one of the active calls on the selected route.

6.1.2 Qualifications on applicability to telecommunication services

SS-CPI is applicable to all basic services defined in ECMA-142.

6.2 Procedure

6.2.1 Provision/withdrawal

SS-CPI shall be provided or withdrawn after pre-arrangement with the service provider.

SS-CPI shall be provided on a per PISN number basis for one or more basic services.

One or more Call Priority Interruption Capability Levels (CPICL) shall be allocated to the served user. The procedure by which CPICL is allocated is outside the scope of this Standard.

CPICL shall have a value in the range 1 (lowest priority) to 3 (highest priority). An implementation may offer one or more CPICL values.

NOTE 4

It is not precluded that CPICL values can be variable, e. g. a user may have the possibility to change the value with a user procedure. The details of such capabilities are outside the scope of this Standard.

At least one of the methods of invoking SS-CPI (see 6.2.2.2) shall be offered.

6.2.2 Normal procedures

6.2.2.1 Activation/deactivation/registration/interrogation

SS-CPI shall be activated upon provision and deactivated upon withdrawal.

Registration and interrogation shall not apply.

6.2.2.2 Invocation and operation

There are two different ways to invoke SS-CPI. A PISN may offer one or both of these ways.

These are:

- i) Consultation: the served user, on being informed that a call has failed because of congestion en route to the destination, shall be able, within a defined period (consultation timer), to request SS-CPI.
- ii) Immediate invocation: the served user shall be able to request SS-CPI as part of the initial call set-up, or as an implementation option, the network can invoke SS-CPI automatically on behalf of the user.

On invocation, CPICL, if provided, shall be assigned one of the offered values.

NOTE 5

As an example, this assignment may be based on a class of service.

6.2.2.2.1 Verification and selection of an established call

If the consultation method is provided to the served user, the following procedure shall apply. If a call fails due to congestion en route to the destination and the PISN is not aware that call priority interruption is not allowed (e. g. because of insufficient CPICL), the PISN shall notify the served user that the call has failed because of congestion and that priority interruption may be possible. The served user may then request SS-CPI.

If the immediate invocation method is provided to the served user, the served user may request SS-CPI with the initial call set-up.

For both invocation alternatives the following shall apply. Upon receiving a call priority interruption request, the PISN shall check that at least one user information channel is available on the selected route.

If a user information channel is available on the selected route, the call shall proceed in accordance with basic call procedures.

If no user information channel is available on the selected route, and in order to determine that interruption is allowed, the PISN shall check that the CPICL value of the received call request is greater than zero (priority call). It shall then check that the Call Priority Interruption Protection Level (CPIPL) value of an active call on the selected route is lower than the CPICL value of the served user. If the PISN does not have knowledge of the CPIPL value of an active call, this call shall be treated as if the call has no protection (i.e. CPIPL value equal to zero).

NOTE 6

CPIPL values are allocated when SS-CPIP is invoked. See 7.2.2.2.

The call that passes these checks shall be selected as the established call. If more than one call passes these checks, the PISN shall select the active call with the lowest CPIPL value as the established call. If more than one call has the same lowest CPIPL, the method used to select the established call from this group of calls shall be implementation dependent. If no active call passes these checks the priority call request may be rejected or some other implementation dependent action may be taken.

NOTE 7

One example of an implementation dependent action is to establish the call on another route, if such a route is available.

When the established call has been selected, the users in the established call may as an option be provided with an Impending priority interruption warning notification and a short delay before the user connection is broken. If this notification is provided, it shall be sent to the users in the established call and the impending priority interruption state shall be entered.

NOTE 8

The Impending priority interruption warning notification can be accompanied by an in-band tone or announcement to all users in the established call.

SS-CPI shall terminate when the call request reaches its destination or leaves the PISN.

6.2.2.2.2 Actions during impending priority interruption state

6.2.2.2.2.1 Impending priority interruption state ends

A time period, time to priority interruption (1-10 seconds as an implementation option), after the Impending priority interruption warning notification has been provided, the users involved in the established call shall be notified of the forced release. The impending priority interruption state shall be terminated, the established call shall be released and the priority call request shall proceed in accordance with basic call procedures selecting the newly available user information channel.

6.2.2.2.2.2 Release of priority call request

If the priority call request is released by the served user during the impending priority interruption state, the users involved in the established call shall be notified that the priority interruption request has been terminated and SS-CPI shall be terminated.

6.2.2.2.2.3 Release of established call

If the established call is released by a user during the impending priority interruption state, the priority call request shall proceed in accordance with basic call procedures selecting the newly available user information channel.

6.2.2.2.2.4 User information channel becomes available

If another user information channel becomes available for this call during the impending priority interruption state, the users involved in the established call shall be notified that the impending priority interruption state has been terminated. The priority call request shall proceed in accordance with basic call procedures selecting the newly available user information channel.

6.2.3 Exceptional procedures

6.2.3.1 Activation/deactivation/registration/interrogation

Not applicable.

6.2.3.2 Invocation and operation

If the interruption request cannot be accepted the request shall be ignored.

6.3 Interaction with other supplementary services and ANFs

Interactions with other supplementary services and ANFs for which PISN standards were available at the time of publication of this Standard are specified below.

6.3.1 Calling Name Identification Presentation (SS-CNIP)

No Interaction.

6.3.2 Connected Name Identification Presentation (SS-CONP)

No interaction.

6.3.3 Completion of Call to Busy Subscriber (SS-CCBS)

SS-CPI may apply to a call resulting from the use of SS-CCBS.

6.3.4 Completion of Call on No Reply (SS-CCNR)

SS-CPI may apply to a call resulting from the use of SS-CCNR.

6.3.5 Call Transfer (SS-CT)

SS-CPI shall not be invoked to interrupt other calls during establishment of the new connection.

6.3.6 Call Forwarding Unconditional (SS-CFU)

SS-CPI may be invoked when establishing the diverted call.

6.3.7 Call Forwarding Busy (SS-CFB)

SS-CPI may be invoked when establishing the diverted call.

6.3.8 Call Forwarding No Reply (SS-CFNR)

SS-CPI may be invoked when establishing the diverted call.

6.3.9 Call Deflection (SS-CD)

SS-CPI may be invoked when establishing the diverted call.

6.3.10 Path Replacement (ANF-PR)

SS-CPI shall not be invoked to interrupt other calls during establishment of the new connection.

6.3.11 Call Offer (SS-CO)

No interaction.

6.3.12 Call Intrusion (SS-CI)

No interaction.

NOTE 9

SS-CI may be used in conjunction with SS-CPI to provide for intrusion if a called user busy condition is determined.

6.3.13 Do not Disturb (SS-DND)

No interaction.

6.3.14 Do not Disturb Override (SS-DNDO)

No interaction.

6.3.15 Advice of Charge (SS-AOC)

No interaction.

6.3.16 Recall (SS-RE)

No interaction.

6.3.17 Call Interception (ANF-CINT)

A SS-CPI request shall have priority over any ANF-CINT request on a network congestion condition. There is no interaction with ANF-CINT for other invocation conditions.

6.3.18 Transit Counter (ANF-TC)

No interaction.

6.3.19 Cordless Terminal Location Registration (SS-CTLR)

No interaction.

6.3.20 Cordless Terminal Incoming Call (ANF-CTMI)

SS-CPI may be invoked when establishing a call to a CTM user.

6.3.21 Cordless Terminal Outgoing Call (ANF-CTMO)

No interaction.

6.3.22 Authentication of a CTM User (SS-CTAU)

No interaction.

6.3.23 Authentication of the PISN (SS-CTAN)

No interaction.

6.3.24 Message Waiting Indication (SS-MWI)

No interaction.

6.3.25 Common Information (ANF-CMN)

No interaction.

6.3.26 Call Priority Interruption Protection (SS-CPIP)

See 6.2.

6.4 Interworking considerations

When interworking with another network which supports an equivalent feature, it may be possible to cooperate with the other network to provide SS-CPI.

6.5 Overall SDL

Figure 1 contains the dynamic description of SS-CPI using the Specification and Description Language (SDL) defined in ITU-T Rec. Z.100 (1993). The SDL process represents the behaviour of the PISN in providing SS-CPI to a served user.

Input symbols from the left and output symbols to the left represent primitives from and to the served user.

Input symbols from the right represent inputs from the basic call process or inputs from an internal process.

Output symbols to the right represent primitives to the users in the established call, outputs to the basic call process or outputs to an internal process.

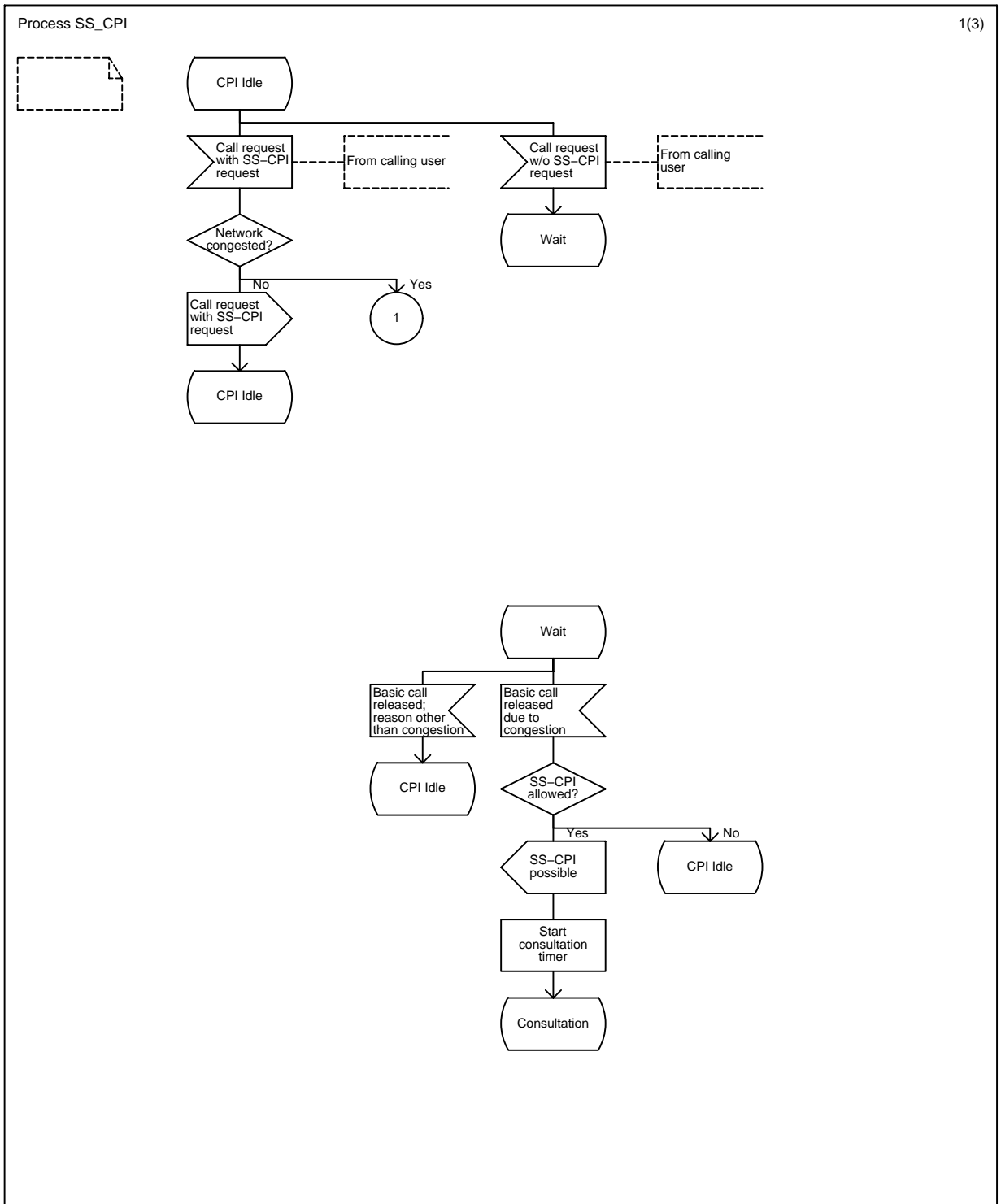

Figure 1 - SS-CPI, overall SDL - Part 1 of 3

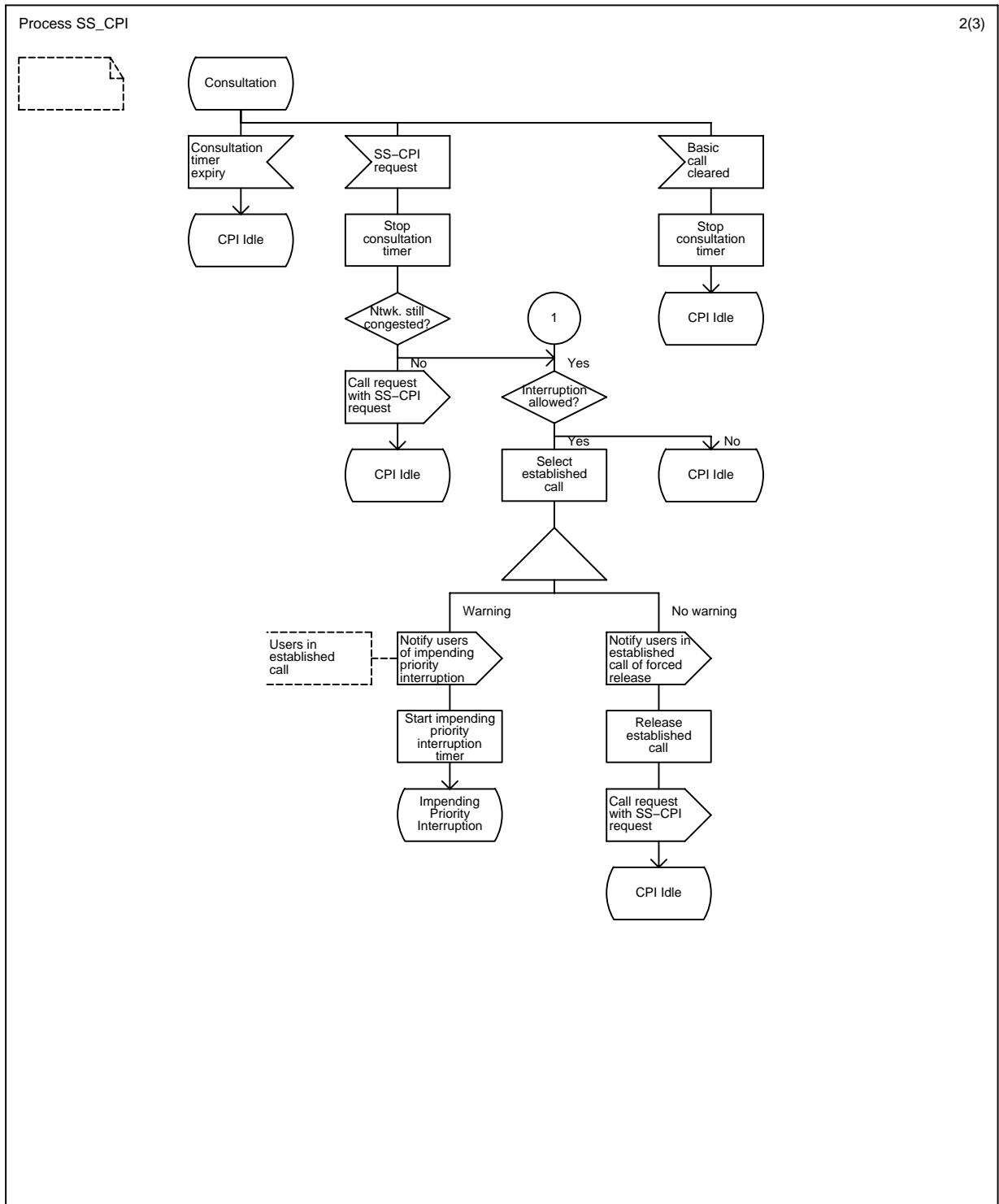

Figure 1 - SS-CPI, overall SDL - Part 2 of 3

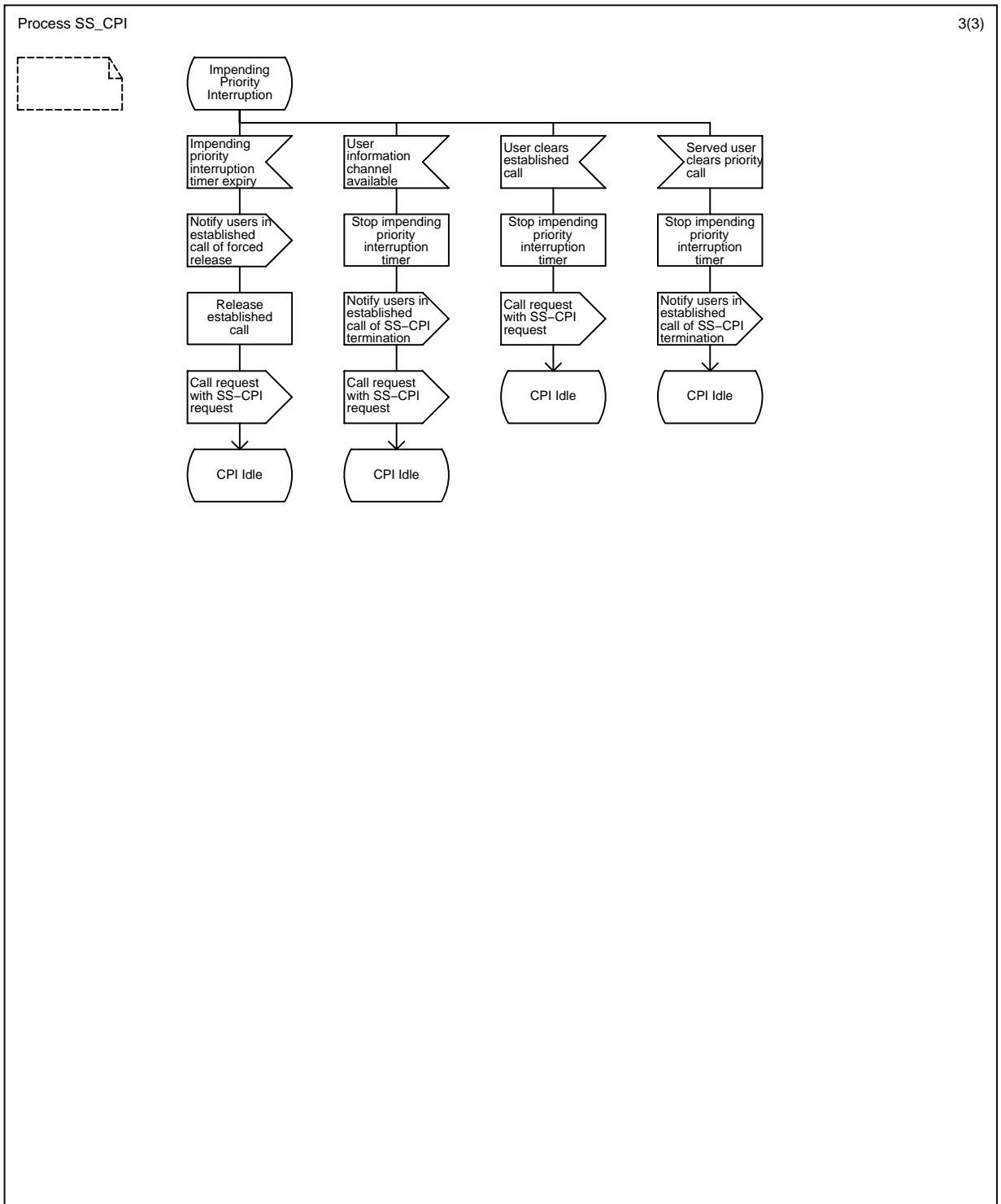

Figure 1 - SS-CPI, overall SDL - Part 3 of 3

7 SS-CPIP stage 1 specification

7.1 Description

7.1.1 General description

Call Priority Interruption Protection (SS-CPIP) is a supplementary service that allows for the protection of calls against interruption.

The served user may be either a calling user or a called user.

7.1.2 Qualifications on applicability to telecommunication services

SS-CPIP is applicable to all basic services defined in ECMA-142.

7.2 Procedure

7.2.1 Provision/withdrawal

SS-CPIP shall be provided or withdrawn after pre-arrangement with the service provider.

SS-CPIP shall be provided on a per PISN number basis for one or more basic services.

One or more Call Priority Interruption Protection Levels (CPIPL) shall be allocated to the served user. CPIPLs may be allocated to gateways to other networks for use on behalf of users outside the PISN. Where no CPIPL is allocated a default value of zero (no protection) shall be assumed. The procedure by which CPIPL is allocated is outside the scope of this Standard.

CPIPL shall have a value in the range 0 (no protection) to 3 (total protection). CPIPL values 0 and 3 shall be offered, and as an implementation option values 1 and 2 may be offered.

NOTE 10

It is not precluded that CPIPL values can be variable, e.g., a user may have the possibility to change the value with a user procedure. The details of such capabilities are outside the scope of this Standard.

7.2.2 Normal procedures

7.2.2.1 Activation/deactivation/registration/interrogation

SS-CPIP shall be activated upon provision and deactivated upon withdrawal.

Registration and interrogation shall not apply.

7.2.2.2 Invocation and operation

SS-CPIP may be invoked by a calling user or by a called user to assign a protection level (CPIPL) to a call. As an implementation option, the network can invoke SS-CPIP automatically on behalf of the served user.

On invocation, a protection level (CPIPL), chosen from the offered values, shall be assigned to the call.

NOTE 11

As an example, this assignment may be based on a class of service.

Where both the calling user and the called user invoke SS-CPIP for the same call, the CPIPL of the call shall be assigned the higher of the values requested.

The CPIPL shall be stored by the network for the lifetime of the call.

7.2.2.2.1 Invocation by a calling user

The calling user shall be able to request SS-CPIP as part of the initial call set-up.

Following the receipt of a call priority protection request, the PISN shall pass on the received CPIPL unchanged towards the call destination.

7.2.2.2.2 Invocation by a called user

The called user shall be able to request SS-CPIP for protection when confirming a call set-up request, to indicate a higher protection level than that associated with the incoming call. This request may be made regardless of whether, or not, the calling user invoked SS-CPIP.

Following the receipt of a call priority protection request which requests a higher protection level, the PISN shall pass on the received CPIPL unchanged towards the origin of the call.

7.2.3 Exceptional procedures

7.2.3.1 Activation/deactivation/registration/interrogation

Not applicable.

7.2.3.2 Invocation and operation

If the protection request cannot be accepted the request shall be ignored.

7.3 Interaction with other supplementary services and ANFs

Interactions with other supplementary services and ANFs for which PISN standards were available at the time of publication of this Standard are specified below.

7.3.1 Calling Name Identification Presentation (SS-CNIP)

No Interaction.

7.3.2 Connected Name Identification Presentation (SS-CONP)

No interaction.

7.3.3 Completion of Call to Busy Subscriber (SS-CCBS)

SS-CPIP may apply to a call resulting from the use of SS-CCBS.

7.3.4 Completion of Call on No Reply (SS-CCNR)

SS-CPIP may apply to a call resulting from the use of SS-CCNR.

7.3.5 Call Transfer (SS-CT)

SS-CPIP may be invoked when establishing the new connection during transfer by re-routeing so that the new connection has the same protection level as the old one.

For transfer by join, the resulting call shall assume the highest of the protection levels of the two calls being joined.

7.3.6 Call Forwarding Unconditional (SS-CFU)

SS-CPIP may be invoked when establishing the diverted call. The forwarded-to user may indicate that a higher protection level is required on the resulting call.

7.3.7 Call Forwarding Busy (SS-CFB)

SS-CPIP may be invoked when establishing the diverted call. The forwarded-to user may indicate that a higher protection level is required on the resulting call.

7.3.8 Call Forwarding No Reply (SS-CFNR)

SS-CPIP may be invoked when establishing the diverted call. The forwarded-to user may indicate that a higher protection level is required on the resulting call.

7.3.9 Call Deflection (SS-CD)

SS-CPIP may be invoked when establishing the diverted call. The deflected-to user may indicate that a higher protection level is required on the resulting call.

7.3.10 Path Replacement (ANF-PR)

SS-CPIP may be invoked when establishing the new connection so that the new connection has the same protection level as the old one.

7.3.11 Call Offer (SS-CO)

No interaction.

7.3.12 Call Intrusion (SS-CI)

No interaction.

7.3.13 Do not Disturb (SS-DND)

No interaction.

7.3.14 Do not Disturb Override (SS-DNDO)

No interaction.

7.3.15 Advice of Charge (SS-AOC)

No interaction.

7.3.16 Recall (SS-RE)

No interaction.

7.3.17 Call Interception (ANF-CINT)

No interaction.

7.3.18 Transit Counter (ANF-TC)

No interaction.

7.3.19 Cordless Terminal Location Registration (SS-CTLR)

No interaction.

7.3.20 Cordless Terminal Incoming Call (ANF-CTMI)

SS-CPIP may be invoked when establishing a call to a CTM user.

7.3.21 Cordless Terminal Outgoing Call (ANF-CTMO)

No interaction.

7.3.22 Authentication of a CTM User (SS-CTAU)

No interaction.

7.3.23 Authentication of the PISN (SS-CTAN)

No interaction.

7.3.24 Message Waiting Indication (SS-MWI)

No interaction.

7.3.25 Common Information (ANF-CMN)

No interaction.

7.3.26 Call Priority Interruption (SS-CPI)

See 6.2.

7.4 Interworking considerations

When interworking with another network which supports an equivalent feature, it may be possible to cooperate with the other network to provide SS-CPIP.

7.5 Overall SDL

Figure 2 contains the dynamic description of SS-CPIP using the Specification and Description Language (SDL) defined in ITU-T Rec. Z.100 (1993). The SDL process represents the behaviour of the PISN in providing SS-CPIP to a served user.

Input symbols from the left and output symbols to the left represent primitives from and to the served user.

Input symbols from the right represent inputs from the basic call process or inputs from an internal process.

Output symbols to the right represent primitives to the users in the established call, outputs to the basic call process or outputs to an internal process.

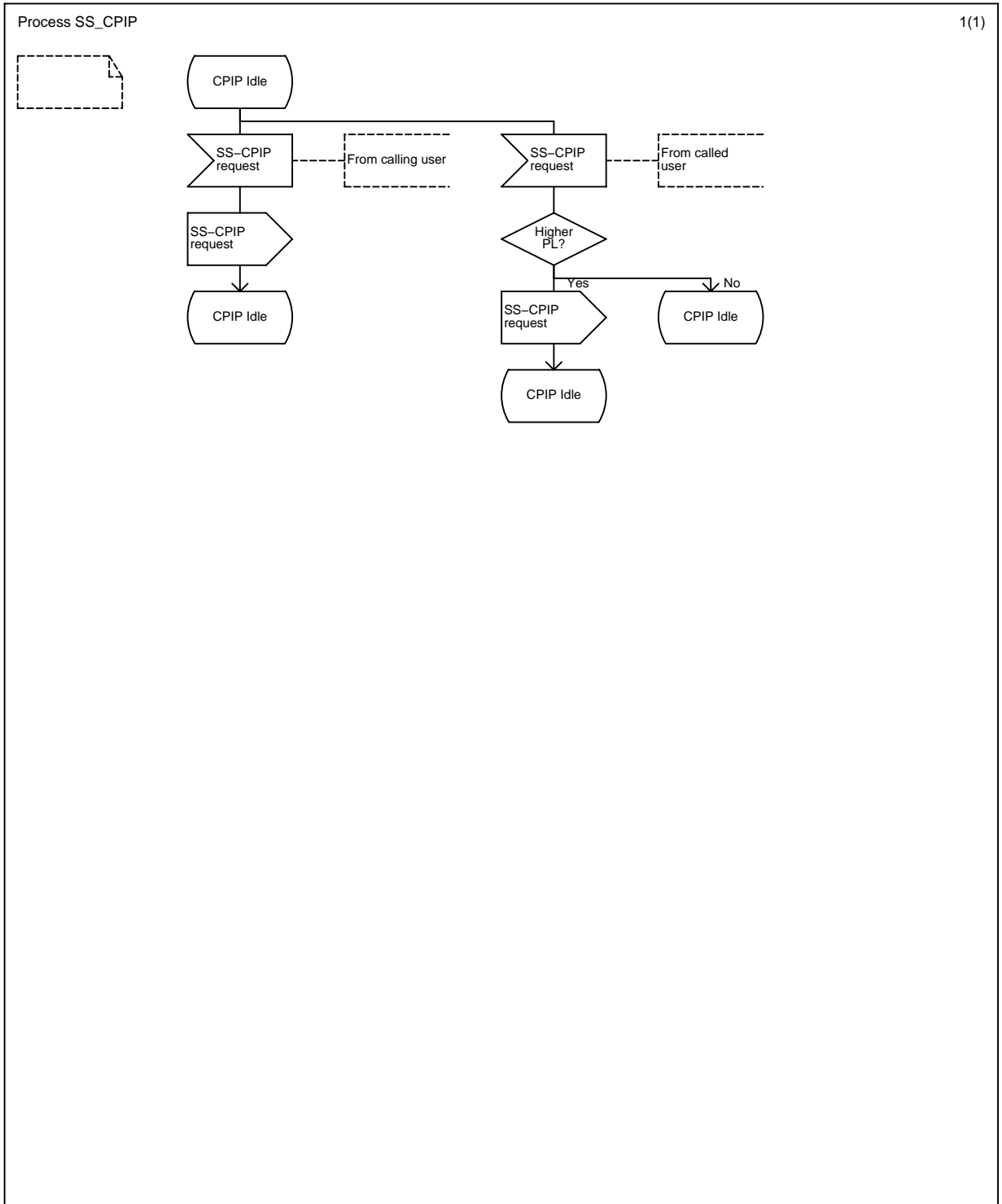

Figure 2 - SS-CPIP, overall SDL - Part 1 of 1

8 SS-CPI stage 2 specification

8.1 Functional model

8.1.1 Functional model description

The functional model shall comprise the following Functional Entities (FE):

- FE1 Served user agent;
- FE2 Served user's control entity;
- FE3 SS-CPI detection and execution entity;
- FE4 Established call user's control entity;
- FE5 Established call user's agent.

The following functional relationships shall exist between these FEs:

- ra between FE1 and FE2;
- rb between FE2 and FE3 and between a pair of FE3s;
- rc between FE3 and FE4s;
- rd between FE4 and FE5;

Figure 3 shows these FEs and relationships.

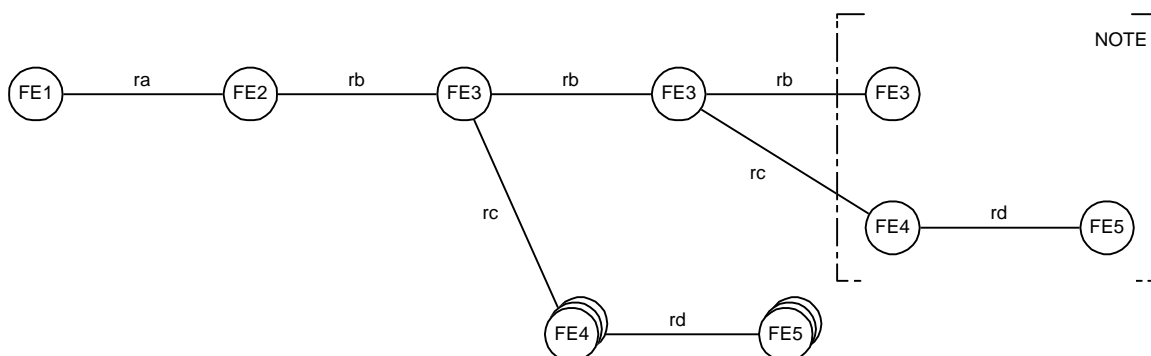

NOTE

Functional entities shown within square brackets repeat as necessary. There is one FE4 and FE5 per user (usually two) in the established call.

Figure 3 - Functional model for SS-CPI

8.1.2 Description of Functional Entities

8.1.2.1 Served user agent, FE1

This functional entity:

- receives requests from the served user and passes these on to FE2;
- receives information from FE2 and passes it on to the served user.

8.1.2.2 Served user's control entity, FE2

This functional entity:

- at the time of original basic call r1_SETUP-request/indication:
 - receives and validates request from FE1 for immediate invocation of SS-CPI;

- determines if immediate invocation or consultation is applicable for the call;
- if SS-CPI is applicable for the call, sends an immediate invocation request to FE3 at the time of the original basic call r2_SETUP-request/indication;
- if consultation applies to the call and all conditions for performing consultation are met:
 - informs FE1 that the original call has encountered congestion and that SS-CPI may be requested;
 - limits the length of the consultation by clearing the call if the served user has not responded, by clearing the call or requesting SS-CPI, within the consultation time;
 - receives request, during consultation, from FE1 for invocation of SS-CPI and sends an appropriate SS-CPI invocation request to FE3.

8.1.2.3 SS-CPI detection and execution entity, FE3

This functional entity:

- on an incoming call with a SS-CPI request checks:
 - for available resources on the selected route;
 - if the necessary resources are not available, releases the active call with the lowest priority (see also 6.2.2.2.2);
 - establishes the priority call by sending an invocation request to the next FE3 at the time of the original basic call r2_SETUP-request/indication.

8.1.2.4 Established call user's control entity, FE4

This functional entity:

- receives information flows from FE3 and forwards these to FE5.

8.1.2.5 Established call user's agent, FE5

This functional entity:

- receives information flows from FE4 and informs the user.

8.1.3 Relationship of functional model to basic call functional model

An example of a relationship between the FEs for SS-CPI and the FEs for the basic call is shown in figure 4.

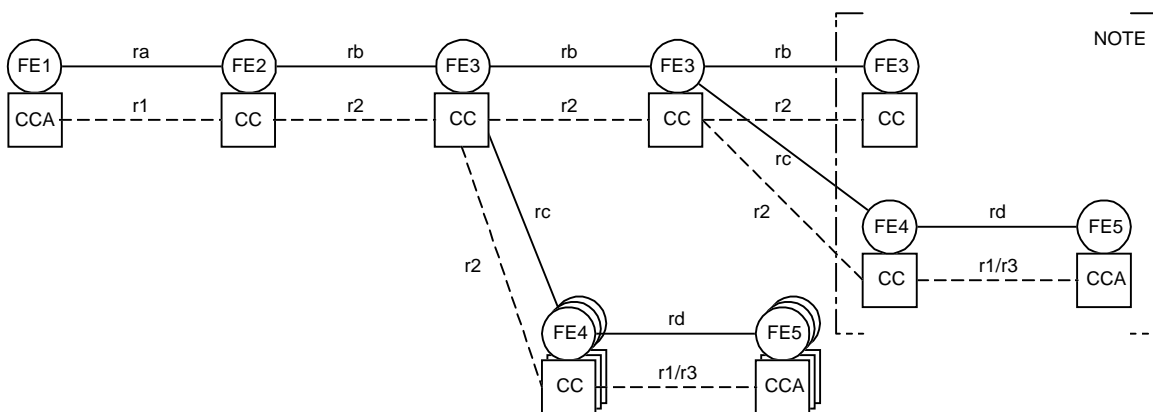

NOTE

Functional entities shown within square brackets repeat as necessary. There is one FE4 and FE5 per user (usually two) in the established call.

Figure 4 - Example relationship between the model for SS-CPI and basic call

8.2 Information flows

8.2.1 Definition of information flows

In the tables listing the elements in information flows, the column headed "Request" indicates which of these elements are mandatory (M) and which are optional (O) in a request/indication information.

8.2.1.1 Relationship ra

8.2.1.1.1 ra_INFORM

ra_INFORM is an unconfirmed information flow sent across ra from FE2 to FE1. It is used to inform FE1 that congestion has been encountered and that SS-CPI may be requested. There are no elements within the ra_INFORM information flow.

8.2.1.1.2 ra_CPI_INV

ra_CPI_INV is an unconfirmed information flow sent across ra from FE1 to FE2. It is used to invoke priority interruption.

Table 1 lists the elements within the ra_CPI_INV information flow.

Table 1 - Content of ra_CPI_INV

Element	Request
CPICL	O (NOTE 12)

NOTE 12

Between FE1 and FE2 this element may be omitted in the case that the served user does not have the capability to change or select CPICL. This element shall be included if and only if interruption is invoked. This element shall have a value in the range 1 (lowest priority) to 3 (highest priority).

8.2.1.2 Relationship rb

8.2.1.2.1 rb_CPI_INV

rb_CPI_INV is an unconfirmed information flow sent across rb from FE2 to FE3, and from FE3 to a subsequent FE3. It is used to invoke priority interruption.

Table 2 lists the elements within the rb_CPI_INV information flow.

Table 2 - Content of rb_CPI_INV

Element	Request
CPICL	M (NOTE 13)

NOTE 13

This element shall have a value in the range 1 (lowest priority) to 3 (highest priority).

8.2.1.3 Relationship rc

8.2.1.3.1 rc_CPI_TERM

rc_CPI_TERM is an unconfirmed information flow sent across rc from FE3 to each FE4. It is used to inform FE4 that the impending priority interruption state has been terminated. There are no elements within the rc_CPI_TERM information flow.

8.2.1.3.2 rc_CPI_WARN

rc_CPI_WARN is an unconfirmed information flow sent across rc from FE3 to each FE4. It is used to inform FE4 that priority interruption is impending. There are no elements within the rc_CPI_WARN information flow.

8.2.1.3.3 rc_FORCED_REL

rc_FORCED_REL is an unconfirmed information flow sent across rc from FE3 to FE4. It is used to inform FE4 that its associated user has been force released. There are no elements within the rc_FORCED_REL information flow.

8.2.1.4 Relationship rd

8.2.1.4.1 rd_CPI_TERM

rd_CPI_TERM is an unconfirmed information flow sent across rd from FE4 to FE5. It is used to inform FE5 that the impending priority interruption state has been terminated. There are no elements within the rd_CPI_TERM information flow.

8.2.1.4.2 rd_CPI_WARN

rd_CPI_WARN is an unconfirmed information flow sent across rd from FE4 to FE5. It is used to inform FE5 that priority interruption is impending. There are no elements within the rd_CPI_WARN information flow.

8.2.1.4.3 rd_FORCED_REL

rd_FORCED_REL is an unconfirmed information flow sent across rd from FE4 to FE5. It is used to inform FE5 that its associated user has been force released. There are no elements within the rd_FORCED_REL information flow.

8.2.2 Relationship of information flows to basic call information flows

Table 3 summarises the relationships of the SS-CPI information flows with those of the basic call.

Table 3 - Relationship of the SS-CPI information flows with the basic call

Information flow			Independent of basic call flow	With basic call flow	Basic call flows
ra	ra_INFORM	request	yes	no	
	ra_CPI_INV	request	yes	yes	r1_SETUP req/ind
rb	rb_CPI_INV	request	no	yes	r2_SETUP req/ind
rc	rc_CPI_TERM	request	yes	no	
	rc_CPI_WARN	request	yes	no	
	rc_FORCED_REL	request	no	yes	r2_RELEASE req/ind
rd	rd_CPI_TERM	request	yes	no	
	rd_CPI_WARN	request	yes	no	
	rd_FORCED_REL	request	no	yes	r1/r3_DISCONNECT req/ind

8.2.3 Information flow sequences

A stage 3 standard for SS-CPI shall provide signalling procedures in support of the information flow sequences specified below. In addition, signalling procedures should be provided to cover other sequences arising from error situations, interactions with basic call, interactions with other supplementary services, different topologies, etc.

In the figures, SS-CPI information flows are represented by solid arrows and basic call information flows are represented by broken arrows. An ellipse embracing two information flows indicates that the two information flows occur simultaneously. Within a column representing a SS-CPI functional entity, the numbers refer to functional entity actions listed in 8.3.

The following abbreviations are used:

req request;

ind indication;

The following timers are used:

T1 Consultation timer;

T2 Impending priority interruption timer.

8.2.3.1 Normal operation, consultation

Figure 5 shows the information flow sequence for a successful priority interruption attempt using consultation.

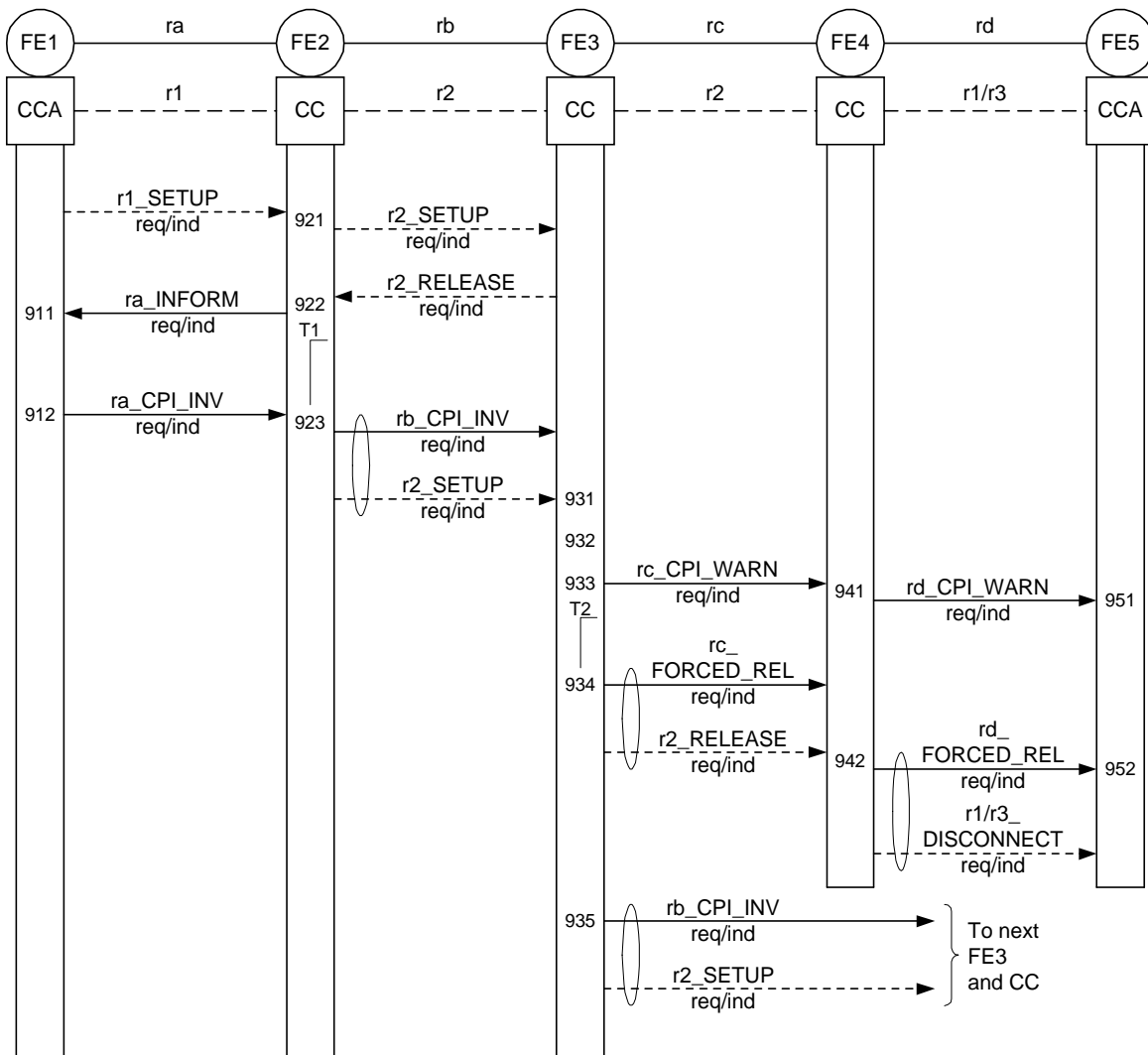

Figure 5 - Information flow sequence for SS-CPI - normal operation, consultation

8.2.3.2 Normal operation, immediate invocation

Figure 6 shows the information flow sequence for a successful priority interruption attempt using immediate invocation.

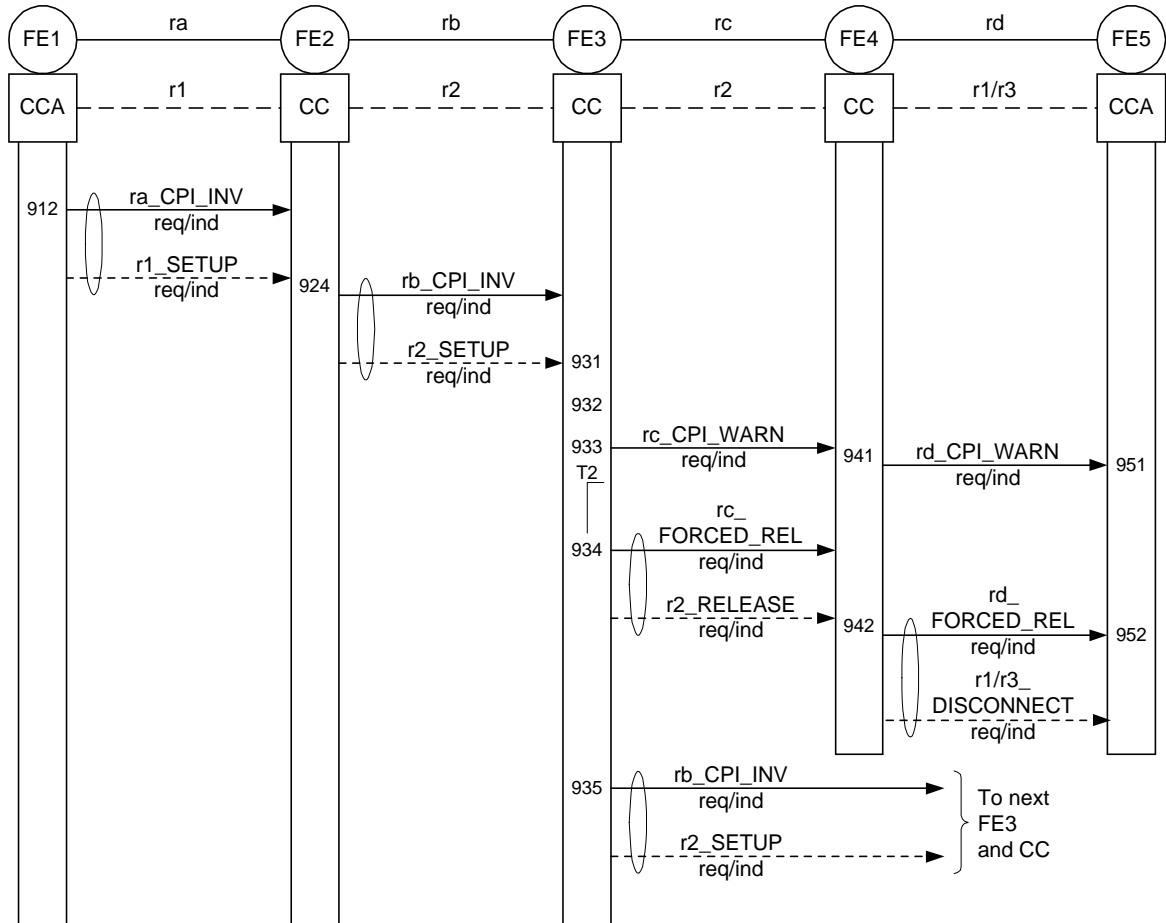

Figure 6 - Information flow sequence for SS-CPI - normal operation, immediate invocation

8.2.3.3 Normal operation, served user releases the priority call

Figure 7 shows the information flow sequence when the priority call is released by the served user during the impending priority interruption state.

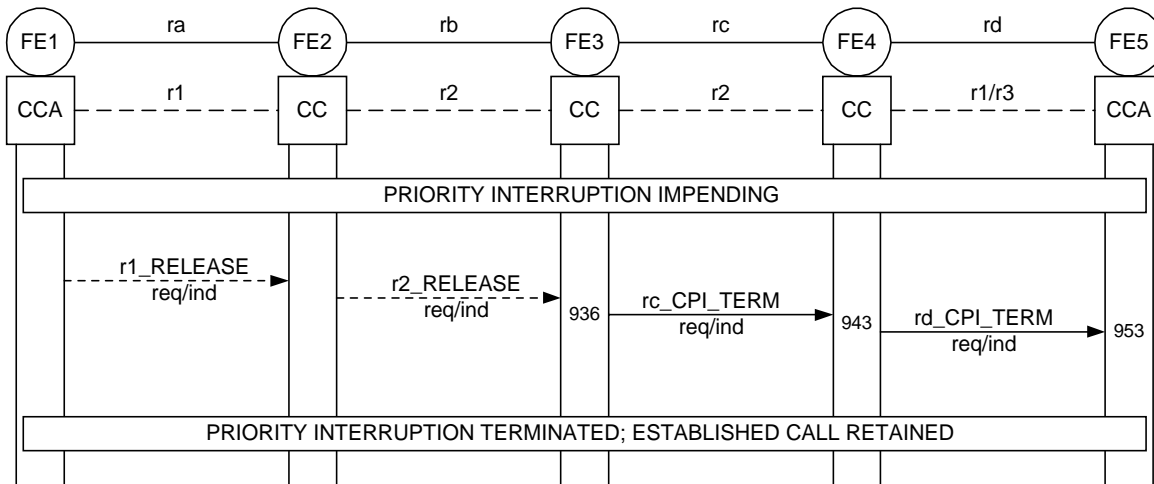

Figure 7 - Information flow sequence for SS-CPI - normal operation, priority call released during impending priority interruption state

8.2.3.4 Normal operation, user information channel becomes available

Figure 8 shows the information flow sequence when a user information channel becomes available during the impending priority interruption state.

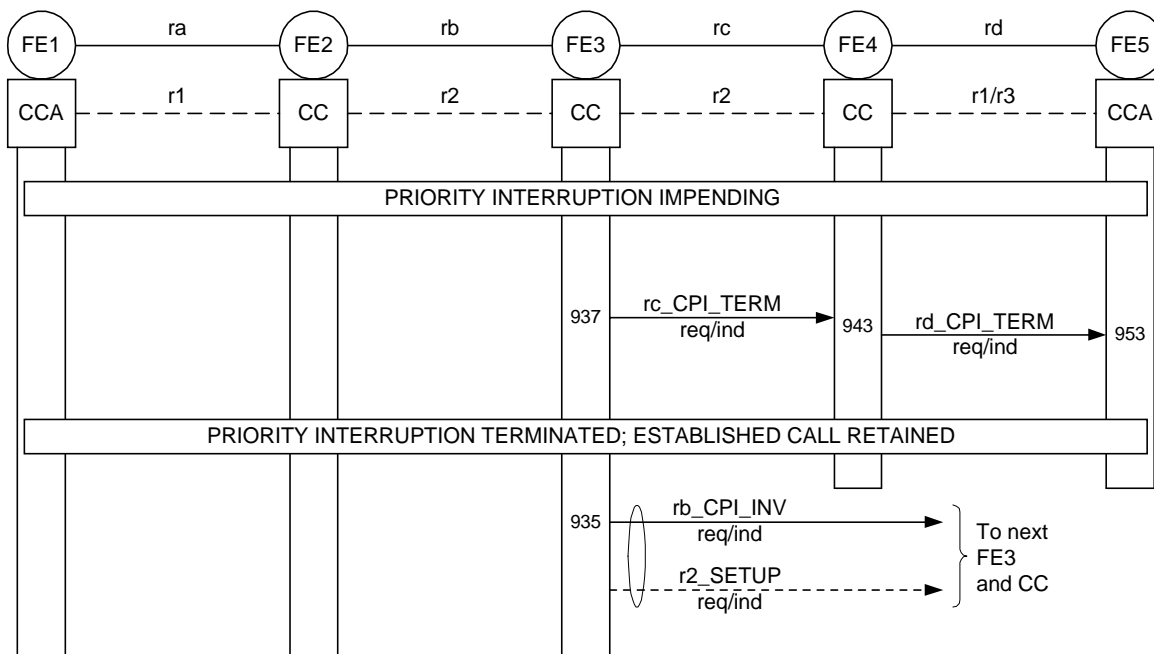

Figure 8 - Information flow sequence for SS-CPI - normal operation, user information channel becomes available during impending priority interruption state

8.3 Functional Entity actions

The following FE actions shall occur at the points indicated in the figures of 8.2.3.

8.3.1 Actions of FE1

- 911: The FE shall receive a ra_INFORM req/ind information flow and inform the served user that congestion has been encountered and that priority interruption may be requested.
- 912: The FE shall receive the user's request for call priority interruption and send a ra_CPI_INV req/ind information flow to FE2, optionally including a CPICL.

8.3.2 Actions of FE2

- 921: All information in the basic call r1_SETUP req/ind information flow shall be retained.
- 922: On receipt of r2_RELEASE_req/ind indicating congestion, the FE shall check whether the user is provided with SS-CPI using the consultation method and, if provided, shall start timer T1 (consultation timer) and store the call information for the duration of T1. The FE shall send a ra_INFORM req/ind flow to FE1. If the user is not provided with the interruption procedure of SS-CPI using the consultation method, the FE shall cause the call to be released.
- 923: The FE shall receive the ra_CPI_INV req/ind information flow from FE1. The FE shall stop the timer T1 and send a rb_CPI_INV req/ind information flow including a CPICL to FE3. If a CPICL has been included in the ra_CPI/INV req/ind information flow received from FE1, this CPICL shall be included in the rb_CPI_INV req/ind information flow sent to FE3.
- 924: The FE shall receive the ra_CPI_INV req/ind information flow from FE1 and check whether the user is provided with SS-CPI using the immediate invocation method. If provided, the FE shall send a rb_CPI_INV req/ind information flow including a CPICL to FE3. If a CPICL has been included in the ra_CPI/INV req/ind information flow received from FE1, this CPICL shall be included in the rb_CPI_INV req/ind information flow sent to FE3. If the user is not provided with SS-CPI using the immediate invocation method, the FE shall ignore the ra_CPI_INV req/ind information flow received from FE1.

8.3.3 Actions of FE3

- 931: The FE shall receive the rb_CPI_INV req/ind information flow from FE2 or from a previous FE3.
- 932: The FE shall compare the CPICL with the CPIPLs for all active calls on the selected route and shall determine whether priority interruption is allowed or not.
- 933: If priority interruption is allowed, the FE shall either send a rc_CPI_WARN req/ind information flow to each FE4 and start timer T2 (impending priority interruption timer) or shall release the established call immediately and send a rc_FORCED_REL req/ind information flow to the FE4s.
- 934: When timer T2 has elapsed, the FE shall release the established call and send a rc_FORCED_REL req/ind information flow to the FE4s.
- 935: The FE shall send a rb_CPI_INV req/ind information flow including the received CPICL to the next FE3.
- 936: If the priority call is released during the impending priority interruption state, the FE shall send the rc_CPI_TERM req/ind information flow to each FE4 and terminate the impending priority interruption state. The established call shall revert back to the state that existed before the warning took place.
- 937: If a user information channel becomes available during the impending priority interruption state, the FE shall send the rc_CPI_TERM req/ind information flow to each FE4 and terminate the impending priority interruption state. The established call shall revert back to the state that existed before the warning took place.

8.3.4 Actions of FE4

- 941: The FE shall receive the rc_CPI_WARN req/ind information flow from FE3 and send a rd_CPI_WARN req/ind information flow to FE5.
- 942: The FE shall receive the rc_FORCED_REL req/ind information flow from FE3 and send a rd_FORCED_REL req/ind information flow to FE5.

943: The FE shall receive the rc_CPI_TERM req/ind information flow from FE3 and send a rd_CPI_TERM req/ind information flow to FE5.

8.3.5 Actions of FE5

951: The FE shall receive the rd_CPI_WARN req/ind information flow from FE4 and provide the user with the impending priority interruption warning notification.

952: The FE shall receive the rd_FORCED_REL req/ind information flow from FE4 and inform the user.

953: The FE shall receive the rd_CPI_TERM req/ind information flow from FE4 and inform the user.

8.4 Functional entity behaviour

The FE behaviours shown below are intended to illustrate typical FE behaviour in terms of information flows sent and received.

The behaviour of each FE is shown using the Specification and Description Language (SDL) defined in ITU-T Rec. Z.100 (1993).

8.4.1 Behaviour of FE1

Figure 9 shows the normal behaviour of FE1. Input symbols from the left and output symbols to the left represent primitives from and to the served user. Input symbols from the right and output symbols to the right represent information flows from and to FE2.

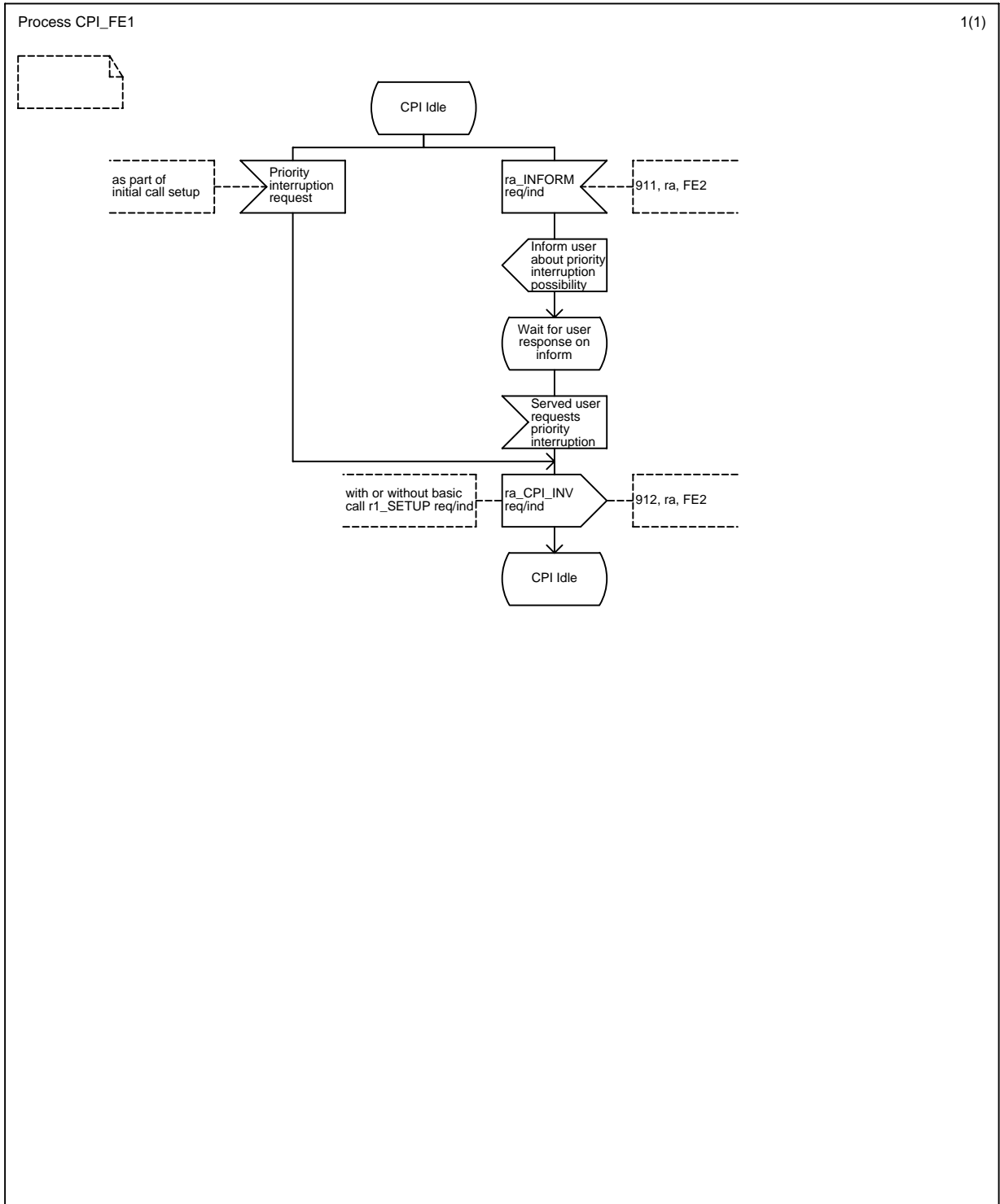

Figure 9 - SS-CPI, SDL for FE1

8.4.2 Behaviour of FE2

Figure 10 shows the normal behaviour of FE2. Input symbols from the left and output symbols to the left represent information flows from and to FE1. Input symbols from the right and output symbols to the right represent information flows from and to FE3 and signals from and to the collocated CC.

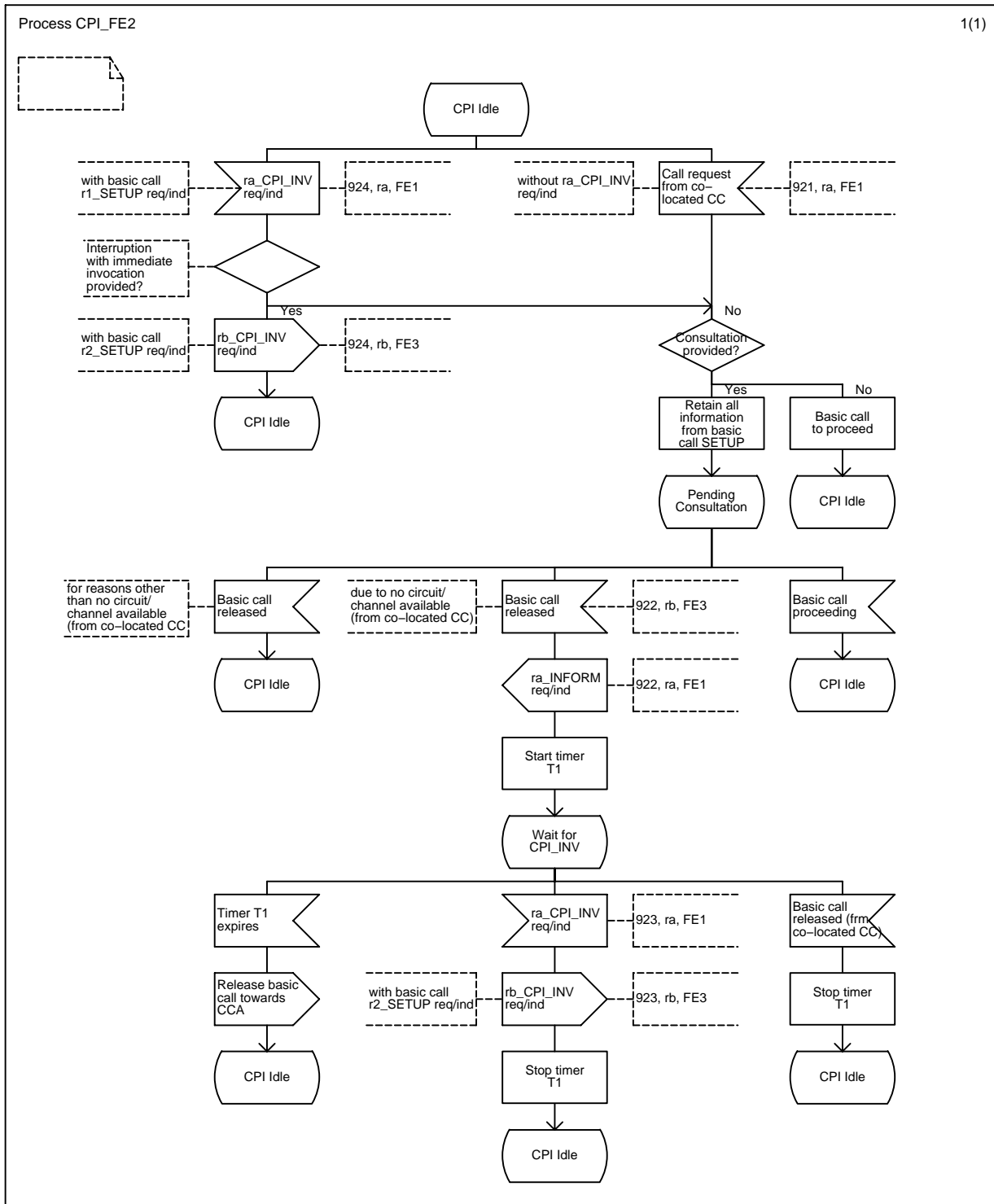

Figure 10 - SS-CPI, SDL for FE2

8.4.3 Behaviour of FE3

Figure 11 shows the normal behaviour of FE3. Input symbols from the left represent information flows from FE2. Input symbols from the right and output symbols to the right represent information flows from and to FE4 and signals from and to the collocated CC.

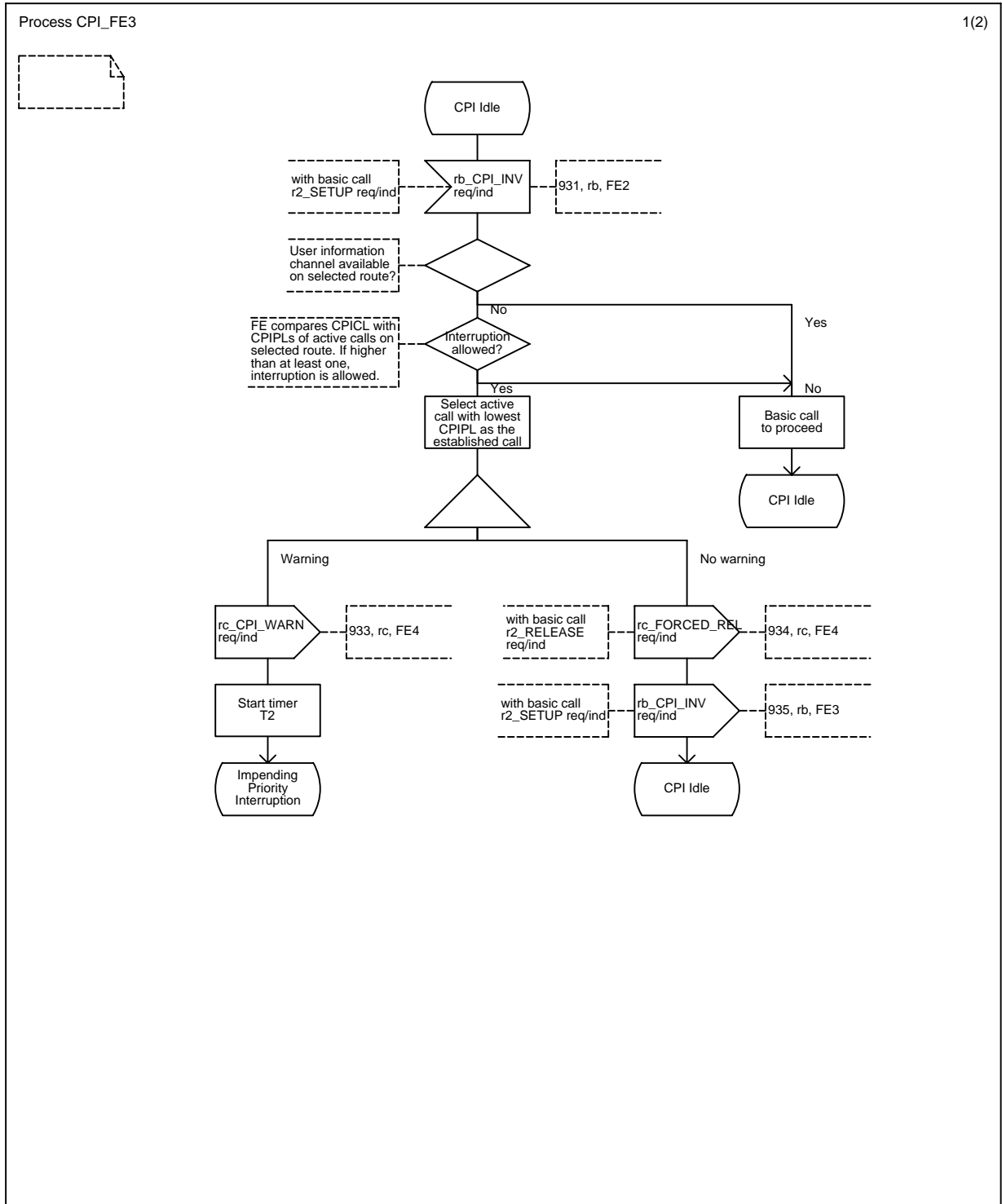

Figure 11 - SS-CPI, SDL for FE3 - Part 1 of 2

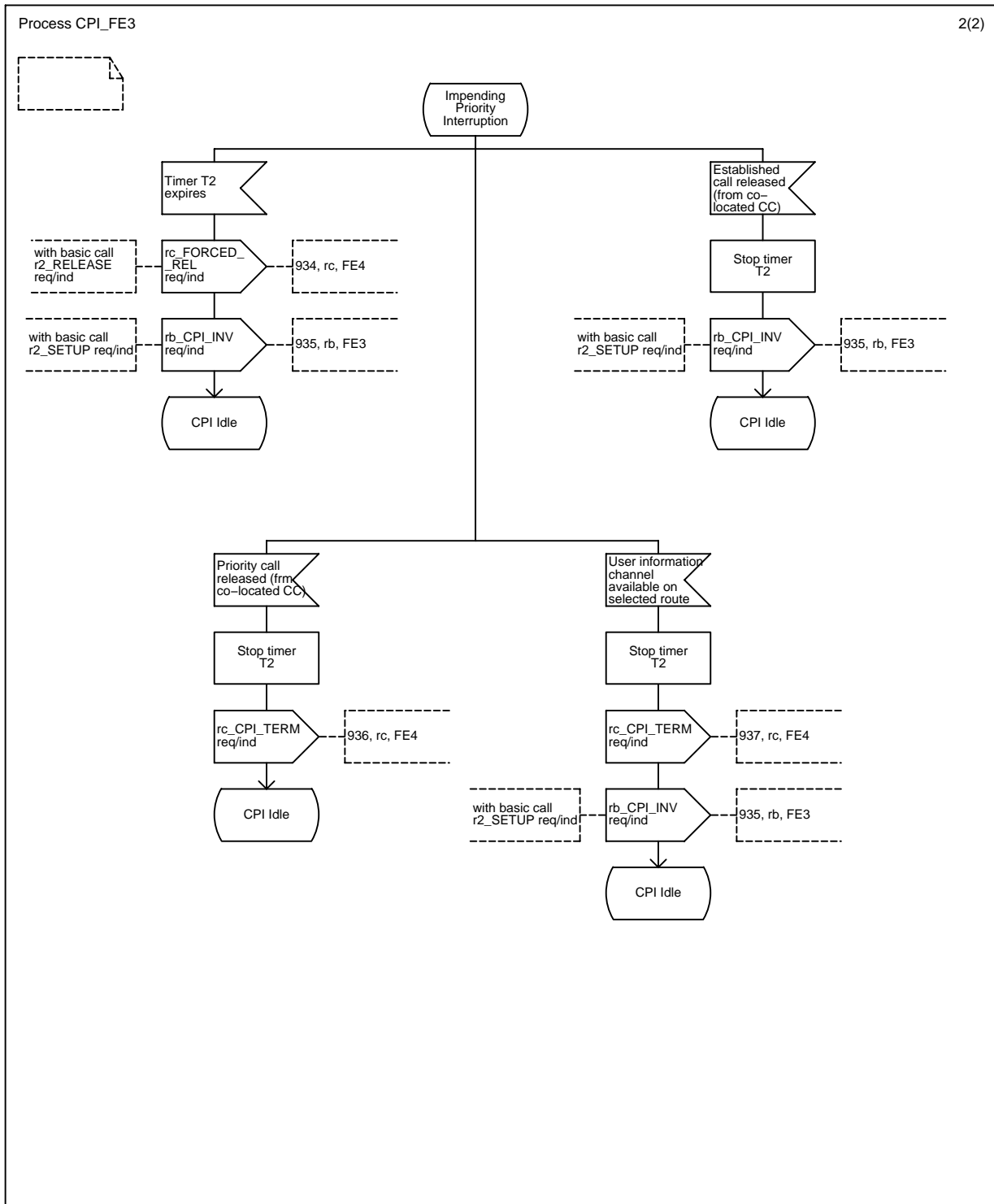

Figure 11 - SS-CPI, SDL for FE3 - Part 2 of 2

8.4.4 Behaviour of FE4

Figure 12 shows the normal behaviour of FE4. Input symbols from the left represent information flows from FE3. Output symbols to the right represent information flows to FE5.

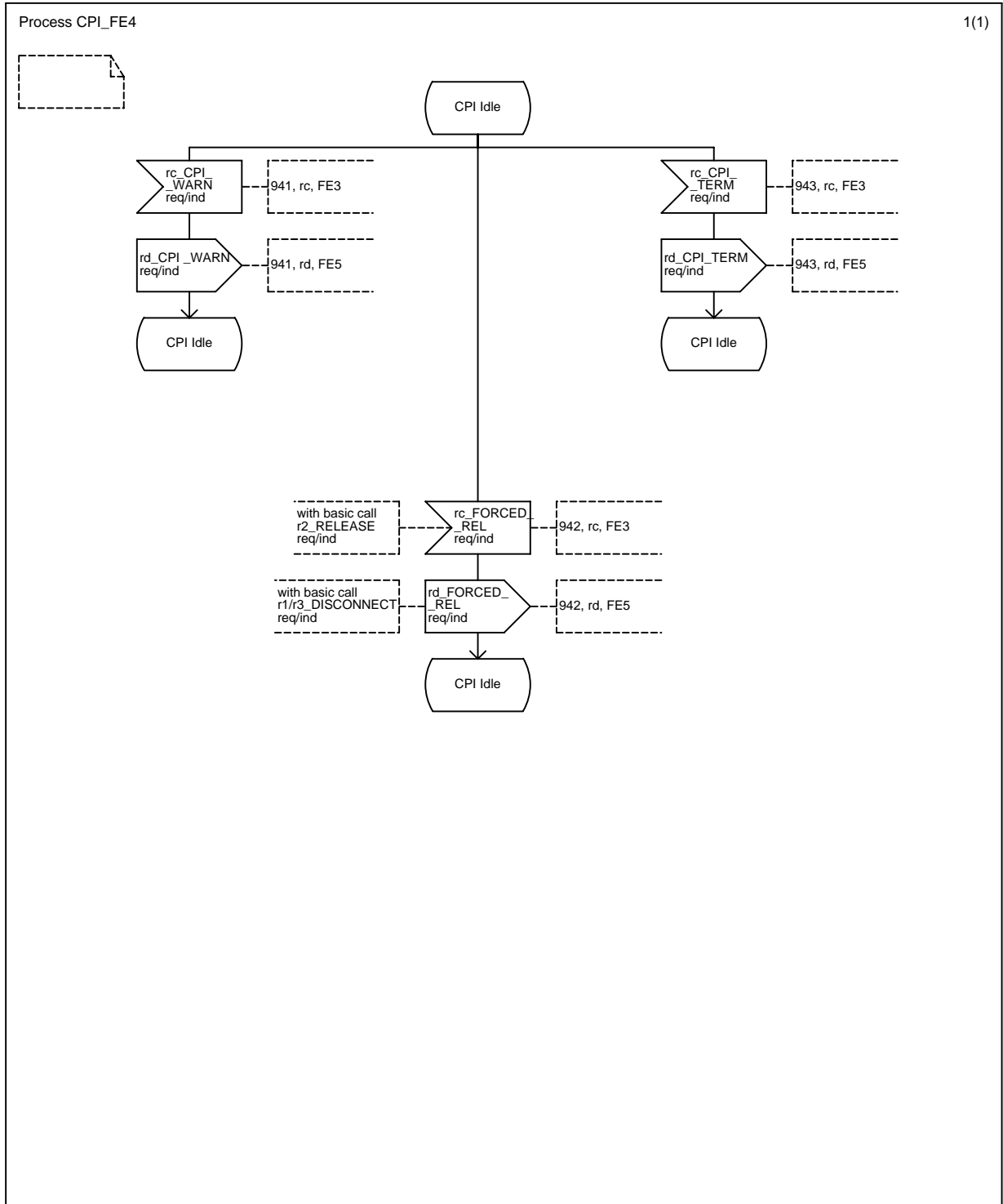

Figure 12 - SS-CPI, SDL for FE4

8.4.5 Behaviour of FE5

Figure 13 shows the normal behaviour of FE5. Input symbols from the left represent information flows from FE4. Output symbols to the right represent primitives to the user.

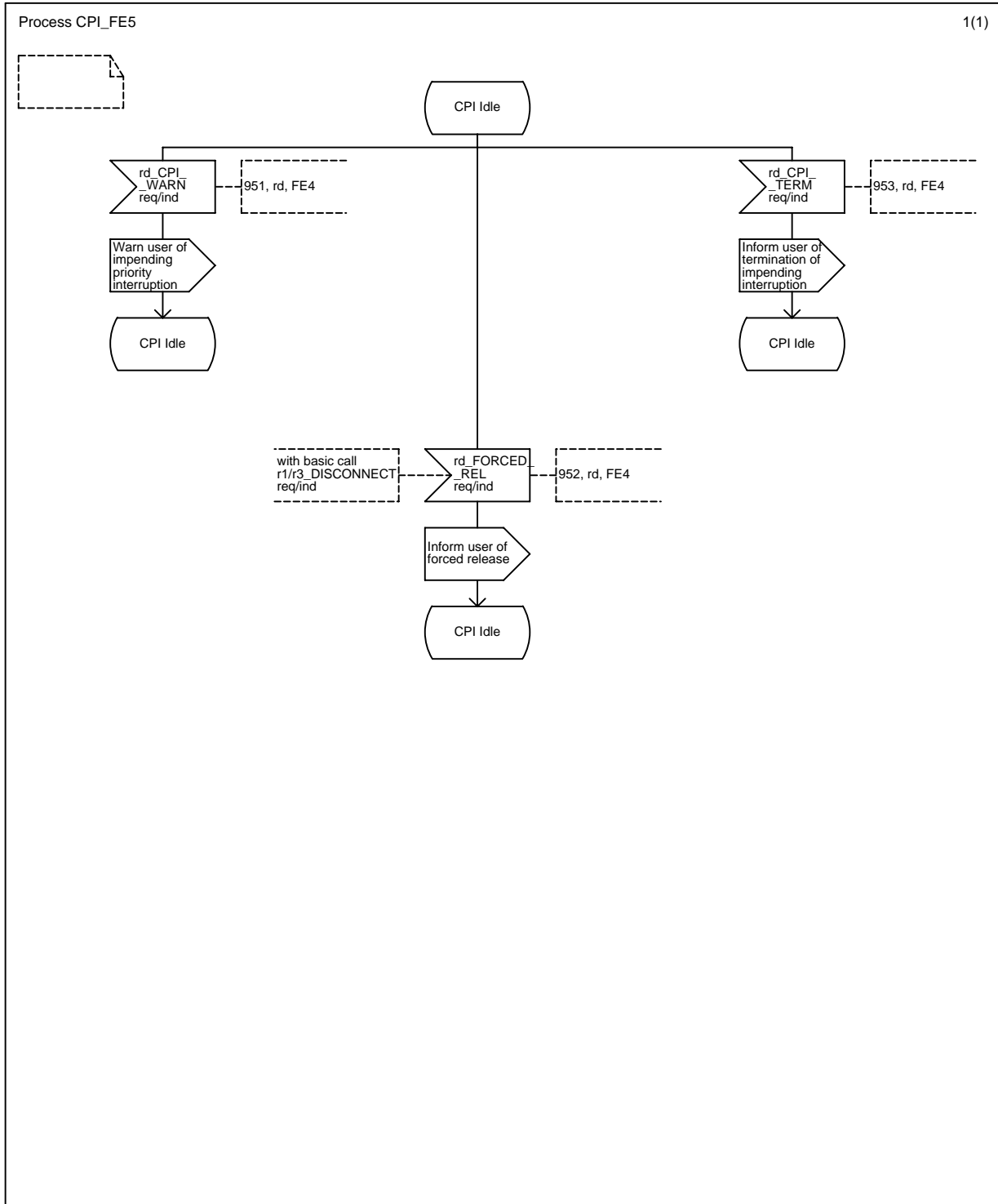

Figure 13 - SS-CPI, SDL for FE5

8.5 Allocation of Functional Entities to physical equipment

Table 4 shows the allocation of Functional Entities to physical equipment. In this table, “TE“ indicates a TE attached to a PISN. Where a terminal involved is stimulus with respect to SS-CPI, any TE shown as residing in the corresponding user’s TE, shall reside instead in that user’s PINX.

Table 4 - Scenarios for the allocation of FEs to physical equipment

Scenario	FE1	FE2	FE3	FE4	FE5
1	Served user TE	Served user PINX	Transit PINX	Established call user's PINX	Established call user's TE
2	Served user TE	Served user PINX	Served user PINX	Established call user's PINX	Established call user's TE

8.6 Interworking considerations

SS-CPI applies only to portions of a call that lie within the PISN. For calls to and from other networks the Functional Entities are allocated to physical equipment as shown in table 5.

Table 5 - Scenarios for the allocation of FEs to physical equipment for normal operation in case of interworking with another network

Scenario	FE1	FE2	FE3	FE4	FE5
3	Other N/W	Other N/W	Incoming Gateway PINX	Established call user's PINX	Established call user's TE
4	Served user TE	Served user PINX	Transit PINX	Outgoing Gateway PINX	Other N/W
5	Served user TE	Served user PINX	Served user PINX	Outgoing Gateway PINX	Other N/W

9 SS-CPIP stage 2 specification

9.1 Functional model

9.1.1 Functional model description

The functional model shall comprise the following Functional Entities (FE):

- FE1 Calling user agent;
- FE2 Calling user's control entity;
- FE3 SS-CPIP transit entity;
- FE4 Called user’s control entity;
- FE5 Called user agent.

The following functional relationships shall exist between these FEs:

- ra between FE1 and FE2;
- rb between FE2 and FE4, between FE2 and FE3, between a pair of FE3s, and between FE3 and FE4;
- rc between FE4 and FE5.

Figure 14 shows these FEs and relationships.

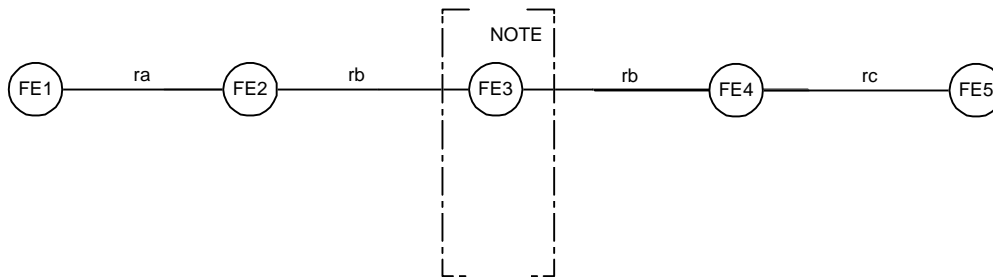

NOTE

Functional entities shown within square brackets may be absent or may repeat as necessary.

Figure 14 - Functional model for SS-CPIP

9.1.2 Description of Functional Entities

9.1.2.1 Calling user agent, FE1

This functional entity:

- receives protection requests from the calling user and passes these on to FE2.

9.1.2.2 Calling user's control entity, FE2

This functional entity:

- receives and validates requests from FE1 for forward invocation of SS-CPIP;
- if SS-CPIP is applicable for the call, sends an invocation request ("forward invocation request") to FE3 or FE4 at the time of the original basic call r2_SETUP-request/indication;
- receives backward invocation requests from FE3 or FE4;
- saves the protection level for the call.

9.1.2.3 SS-CPIP transit entity, FE3

This functional entity:

- on an incoming call with a SS-CPIP request sends a forward invocation request to the next FE3 or to an FE4 at the time of the original basic call r2_SETUP-request/indication;
- receives backward invocation requests from FE4, or a subsequent FE3, and passes them on to FE2, or a preceding FE3;
- saves the protection level for the call.

9.1.2.4 Called user's control entity, FE4

This functional entity:

- receives forward invocation requests from FE2 or FE3;
- receives and validates requests from FE5 for invocation of SS-CPIP in the backward direction;
- if SS-CPIP is applicable in the backward direction (i.e., if the protection level requested by the called user is higher than that requested by the calling user), sends an invocation request ("backward invocation request") to FE2 or FE3 at the time of the r2_SETUP-response/confirm information flows;
- saves the protection level for the call.

9.1.2.5 Called user agent, FE5

This functional entity:

- receives protection requests from the called user and passes these on to FE4.

9.1.3 Relationship of functional model to basic call functional model

An example of a relationship between the FEs for SS-CPIP and the FEs for the basic call is shown in figure 15.

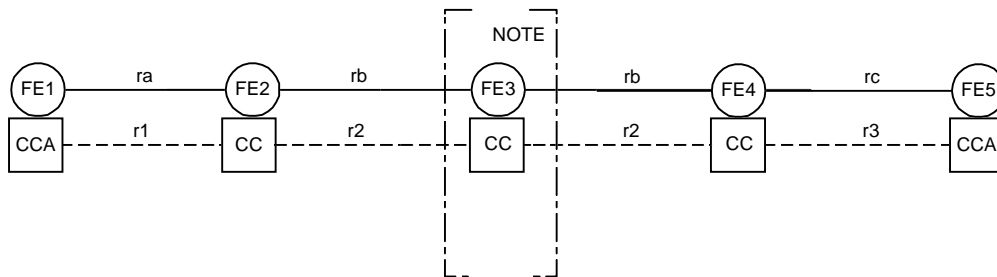

NOTE

Functional entities shown within square brackets may be absent or may repeat as necessary.

Figure 15 - Example relationship between the model for SS-CPIP and basic call

9.2 Information flows

9.2.1 Definition of information flows

In the tables listing the elements in information flows, the column headed "Request" indicates which of these elements are mandatory (M) and which are optional (O) in a request/indication information.

9.2.1.1 Relationship ra

9.2.1.1.1 ra_CPIP_F_INV

ra_CPIP_F_INV is an unconfirmed information flow sent across ra from FE1 to FE2. It is used to invoke protection in the forward direction.

Table 6 lists the elements within the ra_CPIP_F_INV information flow.

Table 6 - Content of ra_CPIP_F_INV

Element	Request
CPIPL	O (NOTE 14)

NOTE 14

Between FE1 and FE2 this element may be omitted in the case that the calling user does not have the capability to change or select CPIPL. This element shall have a value in the range 0 (no protection) to 3 (total protection).

9.2.1.2 Relationship rb

9.2.1.2.1 rb_CPIP_F_INV

rb_CPIP_F_INV is an unconfirmed information flow sent across rb from FE2 to FE4, from FE2 to FE3, from FE3 to a subsequent FE3, and from FE3 to FE4. It is used to invoke protection in the forward direction.

Table 7 lists the elements within the rb_CPIP_F_INV information flow.

Table 7 - Content of rb_CPIP_F_INV

Element	Request
CPIPL	M (NOTE 15)

NOTE 15

This element shall have a value in the range 0 (no protection) to 3 (total protection).

9.2.1.2.2 rb_CPIP_B_INV

rb_CPIP_B_INV is an unconfirmed information flow sent across rb from FE4 to FE2, from FE4 to FE3, from FE3 to a subsequent FE3, and from FE3 to FE2. It is used to invoke protection in the backward direction.

Table 8 lists the elements within the rb_CPIP_B_INV information flow.

Table 8 - Content of rb_CPIP_B_INV

Element	Request
CPIPL	M (NOTE 16)

NOTE 16

This element shall have a value in the range 0 (no protection) to 3 (total protection).

9.2.1.3 Relationship rc

9.2.1.3.1 rc_CPI_B_INV

rc_CPI_B_INV is an unconfirmed information flow sent across rc from FE5 to FE4. It is used to invoke protection in the backward direction.

Table 9 lists the elements within the rc_CPI_B_INV information flow.

Table 9 - Content of rc_CPI_B_INV

Element	Request
CPIPL	O (NOTE 17)

NOTE 17

Between FE5 and FE4 this element may be omitted in the case that the called user does not have the capability to change or select CPIPL. This element shall have a value in the range 0 (no protection) to 3 (total protection).

9.2.2 Relationship of information flows to basic call information flows

Table 10 summarises the relationships of the SS-CPIP information flows with those of the basic call.

Table 10 - Relationship of the SS-CPIP information flows with the basic call

Information flow			Independent of basic call flow	With basic call flow	Basic call flows
ra	ra_CPIP_F_INV	request	no	yes	r1_SETUP req/ind
rb	rb_CPIP_F_INV	request	no	yes	r2_SETUP req/ind
	rb_CPIP_B_INV	request	no	yes	r2_SETUP resp/conf
rc	rc_CPIP_B_INV	request	no	yes	r3_SETUP resp/conf

9.2.3 Information flow sequences

A stage 3 standard for SS-CPIP shall provide signalling procedures in support of the information flow sequences specified below. In addition, signalling procedures should be provided to cover other sequences arising from error situations, interactions with basic call, interactions with other supplementary services, different topologies, etc.

In the figures, SS-CPIP information flows are represented by solid arrows and basic call information flows are represented by broken arrows. An ellipse embracing two information flows indicates that the two information flows occur simultaneously. Within a column representing a SS-CPIP functional entity, the numbers refer to functional entity actions listed in 9.3

The following abbreviations are used:

req request;

ind indication;

The following timers are used:

T1 Consultation timer;

T2 Impending priority interruption timer.

9.2.3.1 Normal operation, forward direction

Figure 16 shows the information flow sequence for a successful protection attempt invoked in the forward direction.

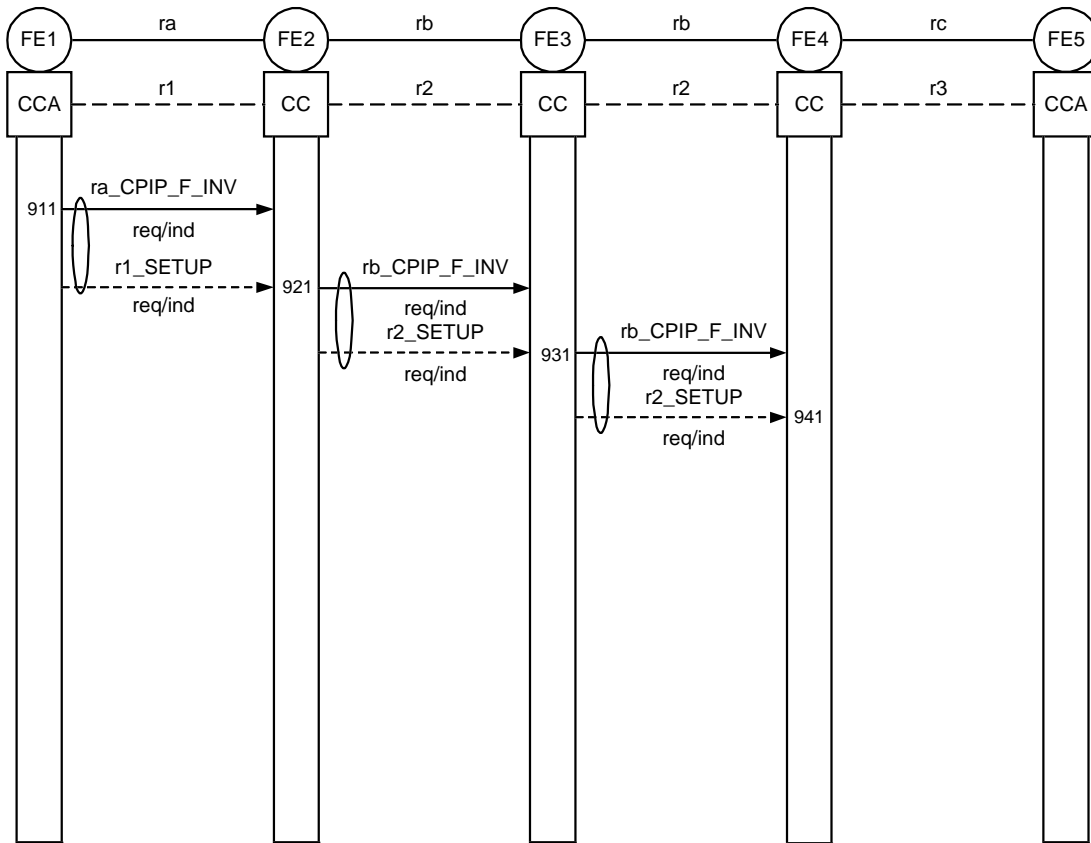

Figure 16 - Information flow sequence for SS-CPIP - normal operation, forward direction

9.2.3.2 Normal operation, both directions

Figure 17 shows the information flow sequence for a successful protection attempt invoked in both directions.

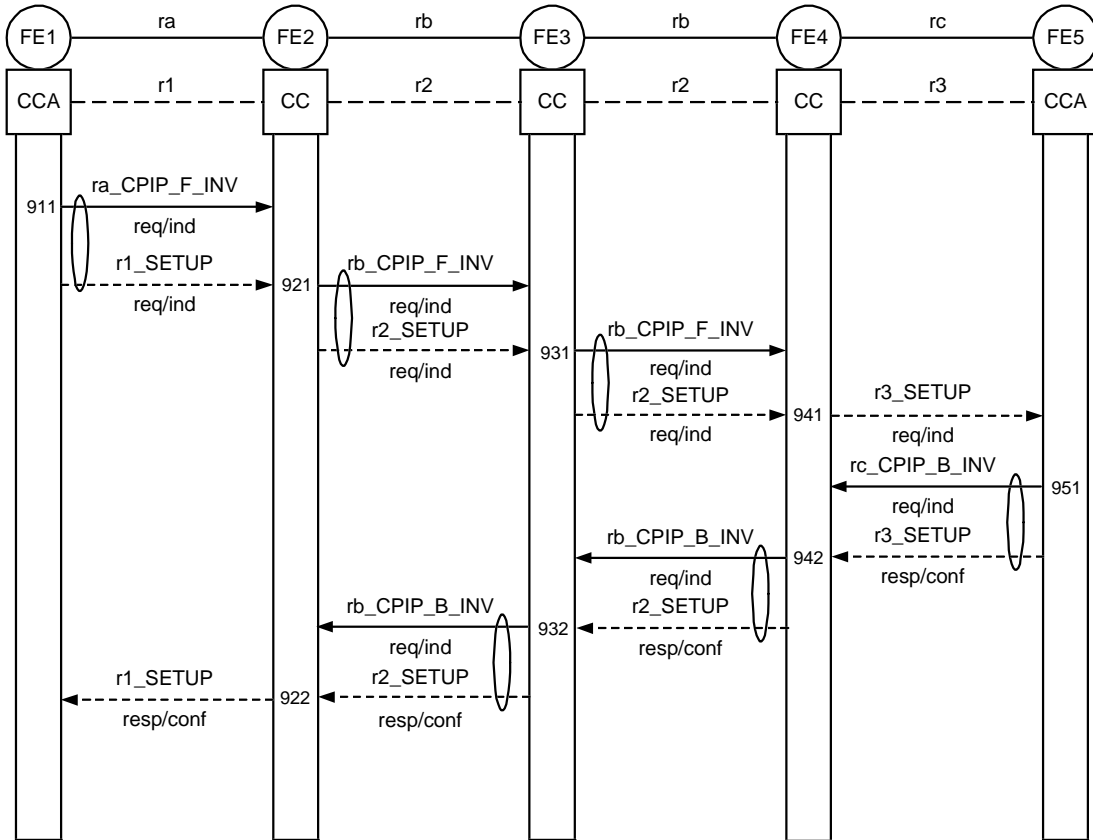

Figure 17 - Information flow sequence for SS-CPIP - normal operation, both directions

9.2.3.3 Normal operation, backward direction

Figure 18 shows the information flow sequence for a successful protection attempt invoked in the backward direction.

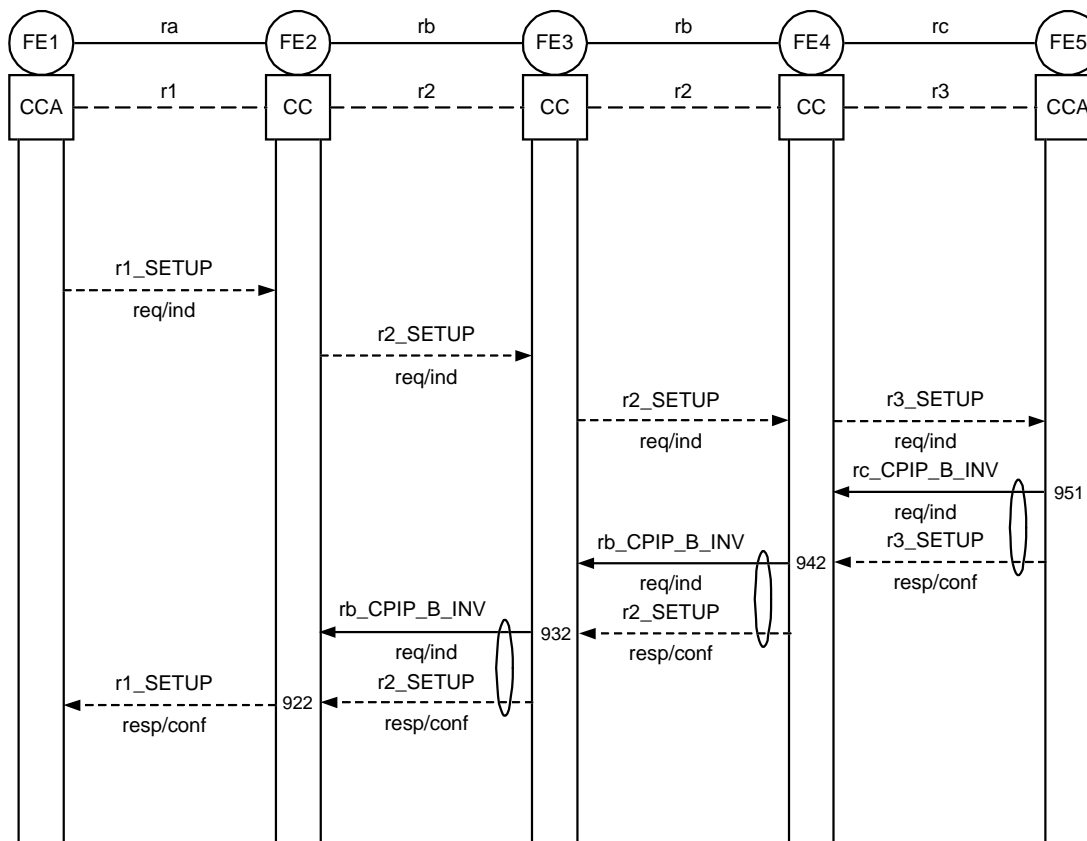

Figure 18 - Information flow sequence for SS-CPIP - normal operation, backward direction

9.3 Functional Entity actions

The following FE actions shall occur at the points indicated in the figures of 9.2.3.

9.3.1 Actions of FE1

911: The FE shall receive the user's request for call protection and send a **ra_CPIP_F_INV req/ind** to FE2, optionally including CPIPL.

9.3.2 Actions of FE2

921: The FE shall receive the **ra_CPIP_F_INV req/ind** information flow from FE1 and check whether the user is provided with the forward invocation procedure of SS-CPIP. If provided, the FE shall send a **rb_CPIP_F_INV req/ind** information flow including a CPIPL to FE4 or FE3. If a CPIPL has been included in the **ra_CPIP_F_INV req/ind** information flow received from FE1, this CPIPL shall be included in the **rb_CPIP_F_INV req/ind** information flow sent to FE4 or FE3. The FE shall save the protection level of the call. If the user is not provided with the forward invocation procedure of SS-CPIP, the FE shall ignore the **ra_CPIP_F_INV req/ind** information flow received from FE1.

922: The FE shall receive the **rb_CPIP_B_INV req/ind** information flow from FE4 or FE3. The FE shall save the value of the CPIPL included in the **rb_CPIP_B_INV req/ind** information flow as the protection level for the duration of the call.

NOTE 18

If SS-CPIP has not previously been invoked in the forward direction for the call, the "saved" protection level will be zero.

9.3.3 Actions of FE3

- 931: The FE shall receive the rb_CPIP_F_INV req/ind information flow from FE2 or from a previous FE3, and shall store the CPIPL value as the protection level for the duration of the call. The FE shall send a rb_CPIP_F_INV req/ind information flow including the received CPIPL to the next FE3 (if there is one) or to FE4.
- 932: The FE shall receive the rb_CPIP_B_INV req/ind information flow from FE4 or from a previous FE3. The FE shall save the value of the CPIPL included in the rb_CPIP_B_INV req/ind information flow as the protection level for the duration of the call.

NOTE 19

If SS-CPIP has not previously been invoked in the forward direction for the call, the "saved" protection level will be zero.

The FE shall send a rb_CPIP_INV req/ind information flow including the received CPIPL to the next FE3 (if there is one) or to FE2.

9.3.4 Actions of FE4

- 941: The FE shall receive the rb_CPIP_F_INV req/ind information flow from FE2 or from a previous FE3, and shall store the CPIPL value as the protection level for the duration of the call.
- 942: The FE shall receive the rc_CPIP_B_INV req/ind information flow from FE5 and check whether the user is provided with the backward invocation procedure of SS-CPIP. The FE shall also check whether a CPIPL has been included in the ra_CPI_B_INV req/ind information flow received from FE5. If the backward invocation procedure is provided, and if the CPIPL has a higher value than that already saved for the call, the FE shall save this value as the protection level for the duration of the call.

NOTE 20

If SS-CPIP has not previously been invoked in the forward direction for the call, the "saved" protection level will be zero.

The FE shall send a rb_CPIP_B_INV req/ind information flow including a CPIPL to FE3 or FE2. If a CPIPL has been included in the ra_CPI_B_INV req/ind information flow received from FE5, this CPIPL shall be included in the rb_CPIP_B_INV req/ind information flow sent to FE3 or FE2. If the user is not provided with the backward invocation procedure of SS-CPIP, or if the CPIPL does not have a higher value than that already saved for the call, the FE shall ignore the rc_CPIP_B_INV req/ind information flow received from FE5.

9.3.5 Actions of FE5

- 951: The FE shall receive the user's request for call protection and send a rc_CPIP_B_INV req/ind to FE4, optionally including CPIPL.

9.4 Functional entity behaviour

The FE behaviours shown below are intended to illustrate typical FE behaviour in terms of information flows sent and received.

The behaviour of each FE is shown using the Specification and Description Language (SDL) defined in ITU-T Rec. Z.100 (1993).

9.4.1 Behaviour of FE1

Figure 19 shows the normal behaviour of FE1. Input symbols from the left and output symbols to the left represent primitives from and to the calling user. Input symbols from the right and output symbols to the right represent information flows from and to FE2.

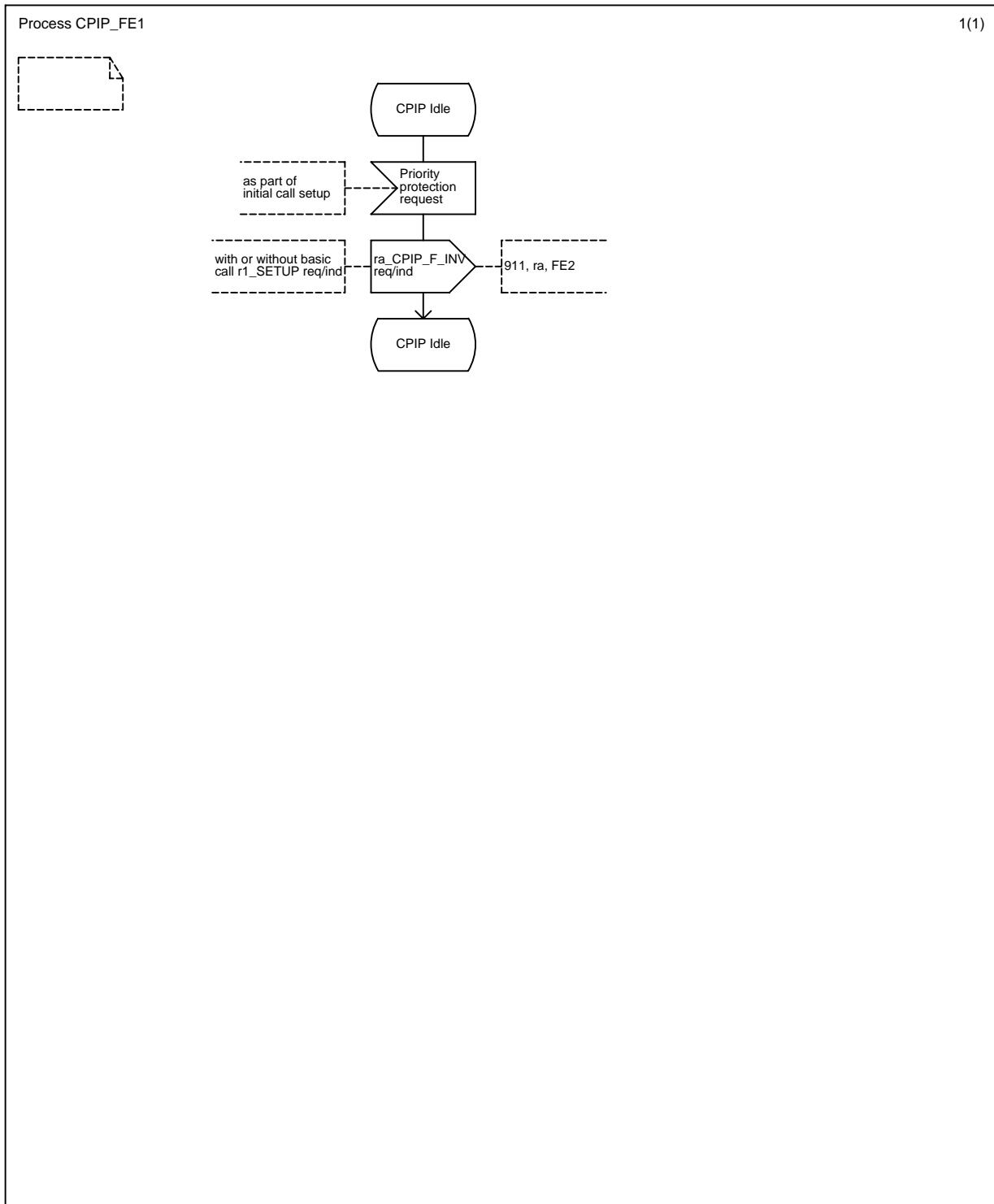

Figure 19 - SS-CPIP, SDL for FE1

9.4.2 Behaviour of FE2

Figure 20 shows the normal behaviour of FE2. Input symbols from the left and output symbols to the left represent information flows from and to FE1. Input symbols from the right and output symbols to the right represent information flows from and to FE3 or FE4 and signals from and to the collocated CC.

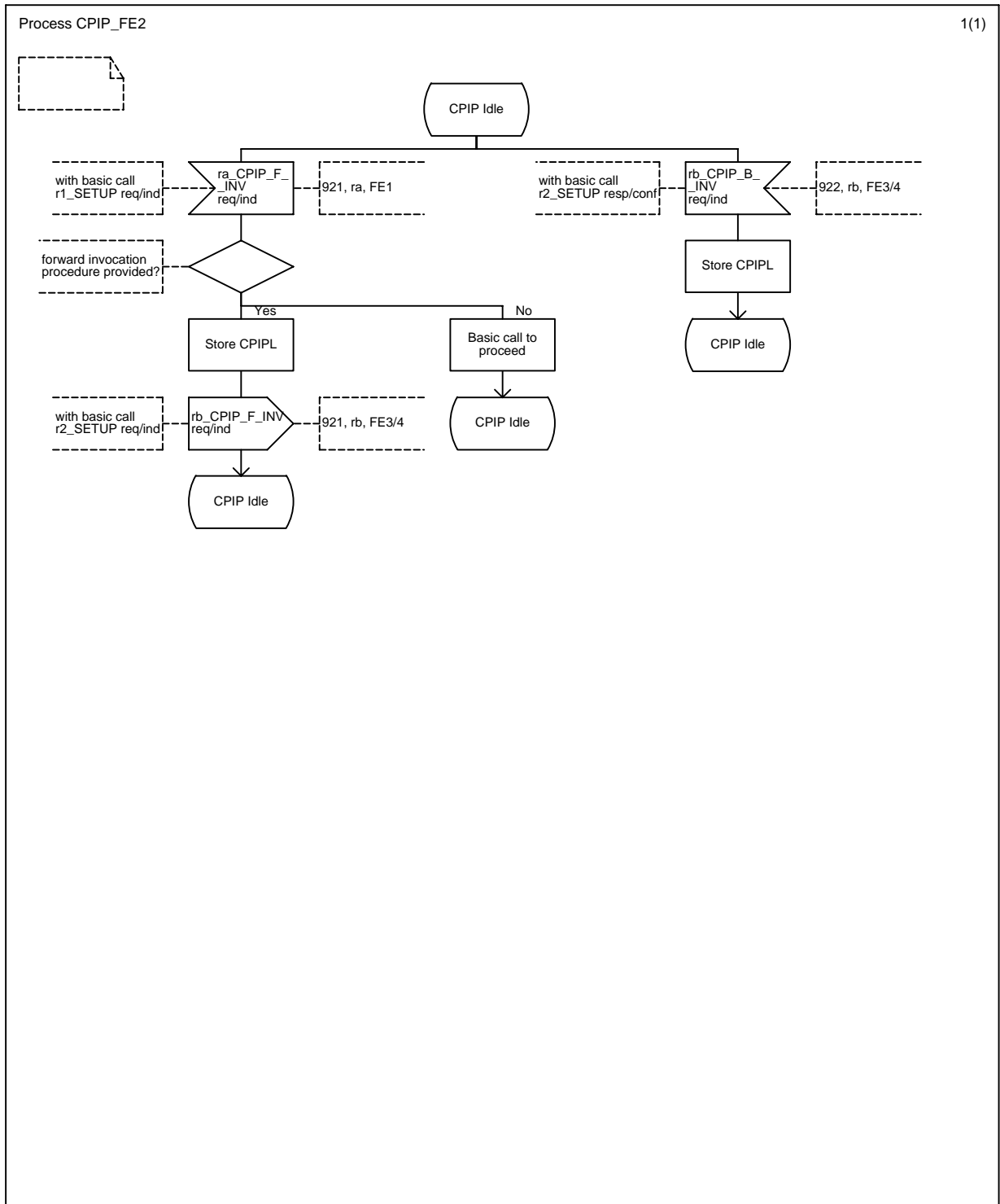

Figure 20 - SS-CPIP, SDL for FE2

9.4.3 Behaviour of FE3

Figure 21 shows the normal behaviour of FE3. Input symbols from the left represent information flows from FE2. Input symbols from the right and output symbols to the right represent information flows from and to FE4 and signals from and to the collocated CC.

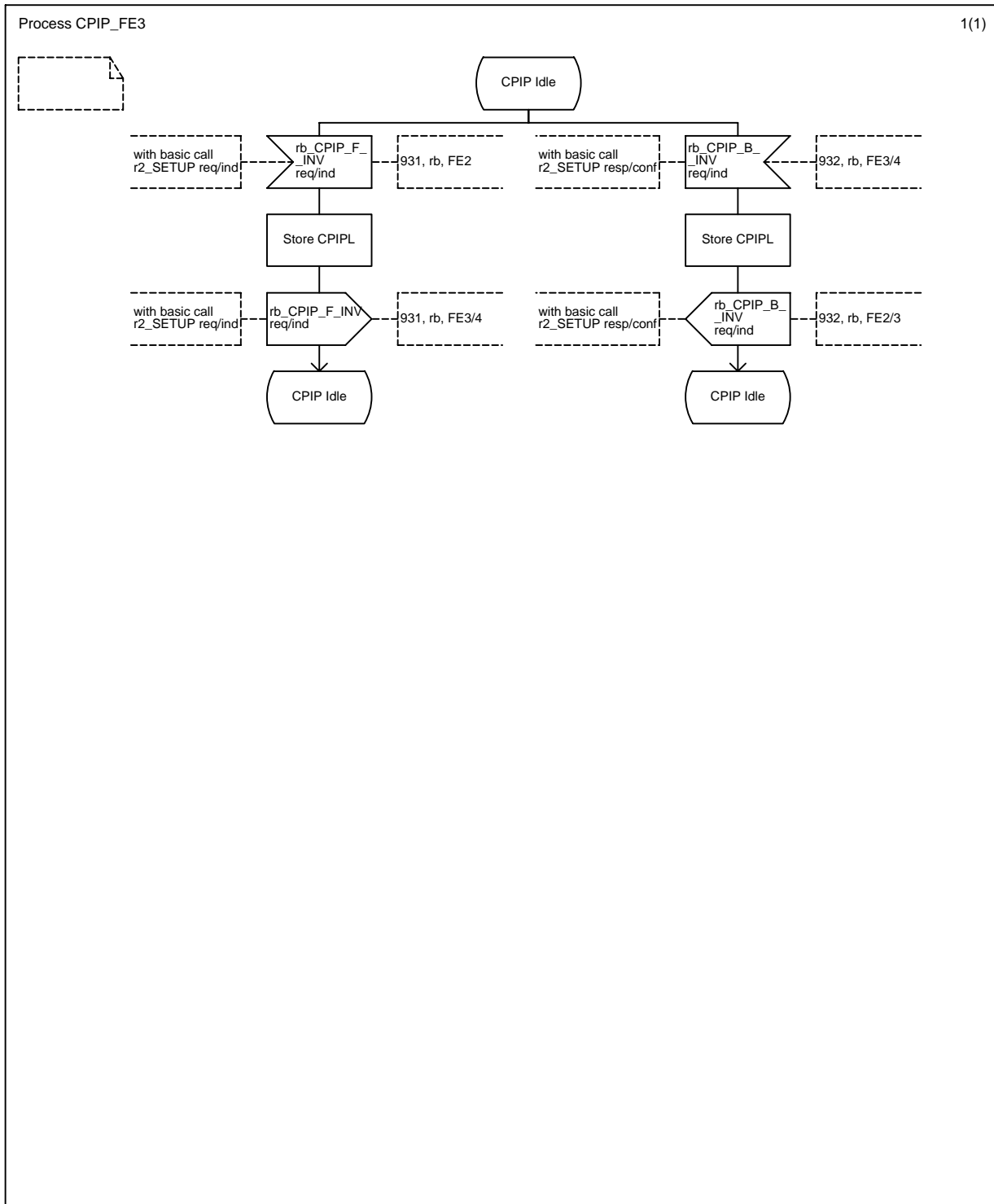

Figure 21 - SS-CPIP, SDL for FE3

9.4.4 Behaviour of FE4

Figure 22 shows the normal behaviour of FE4. Input symbols from the left represent information flows from FE3. Output symbols to the right represent information flows to FE5.

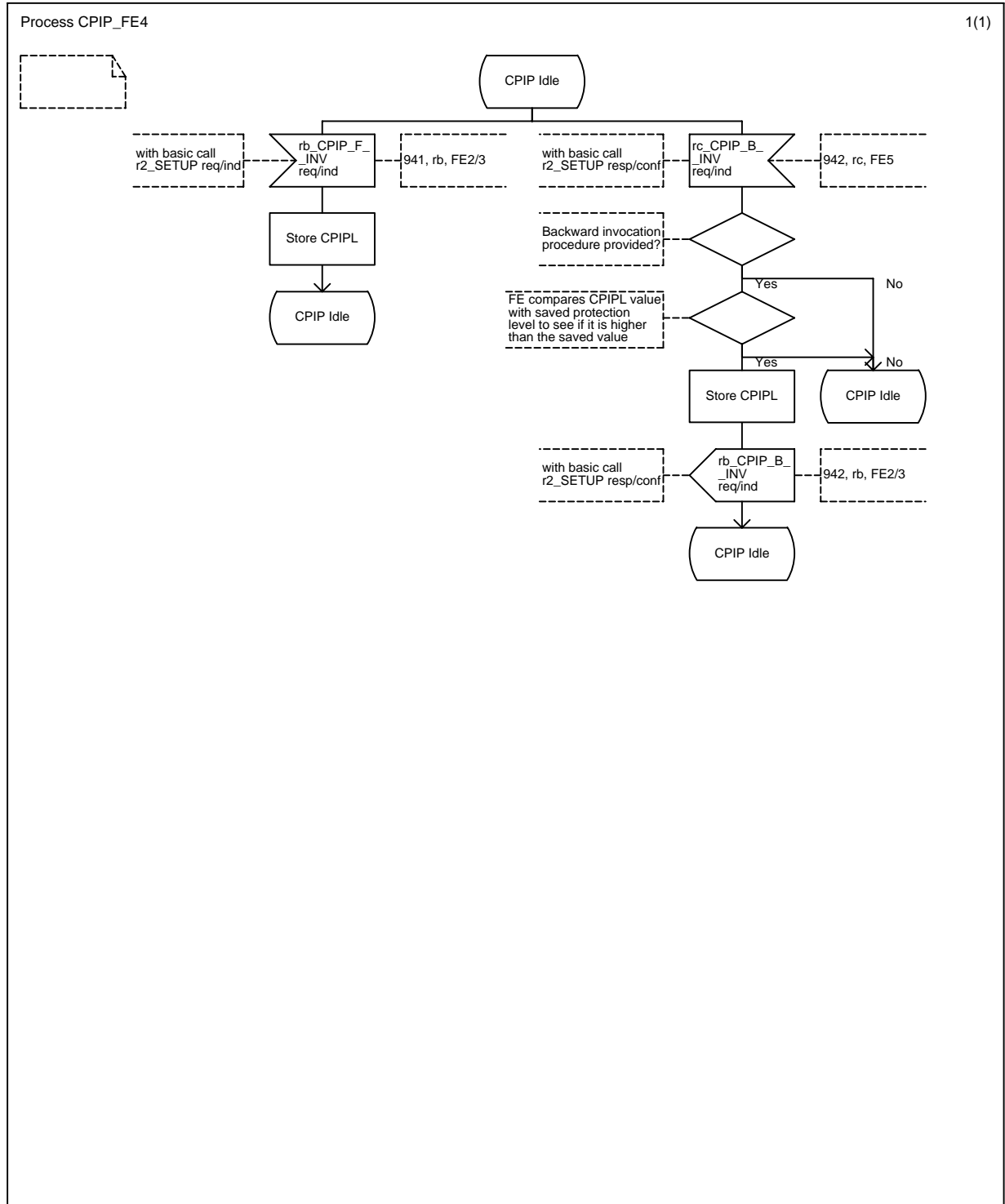

Figure 22 - SS-CPIP, SDL for FE4

9.4.5 Behaviour of FE5

Figure 23 shows the normal behaviour of FE5. Input symbols from the left represent information flows from FE4. Output symbols to the right represent primitives to the user.

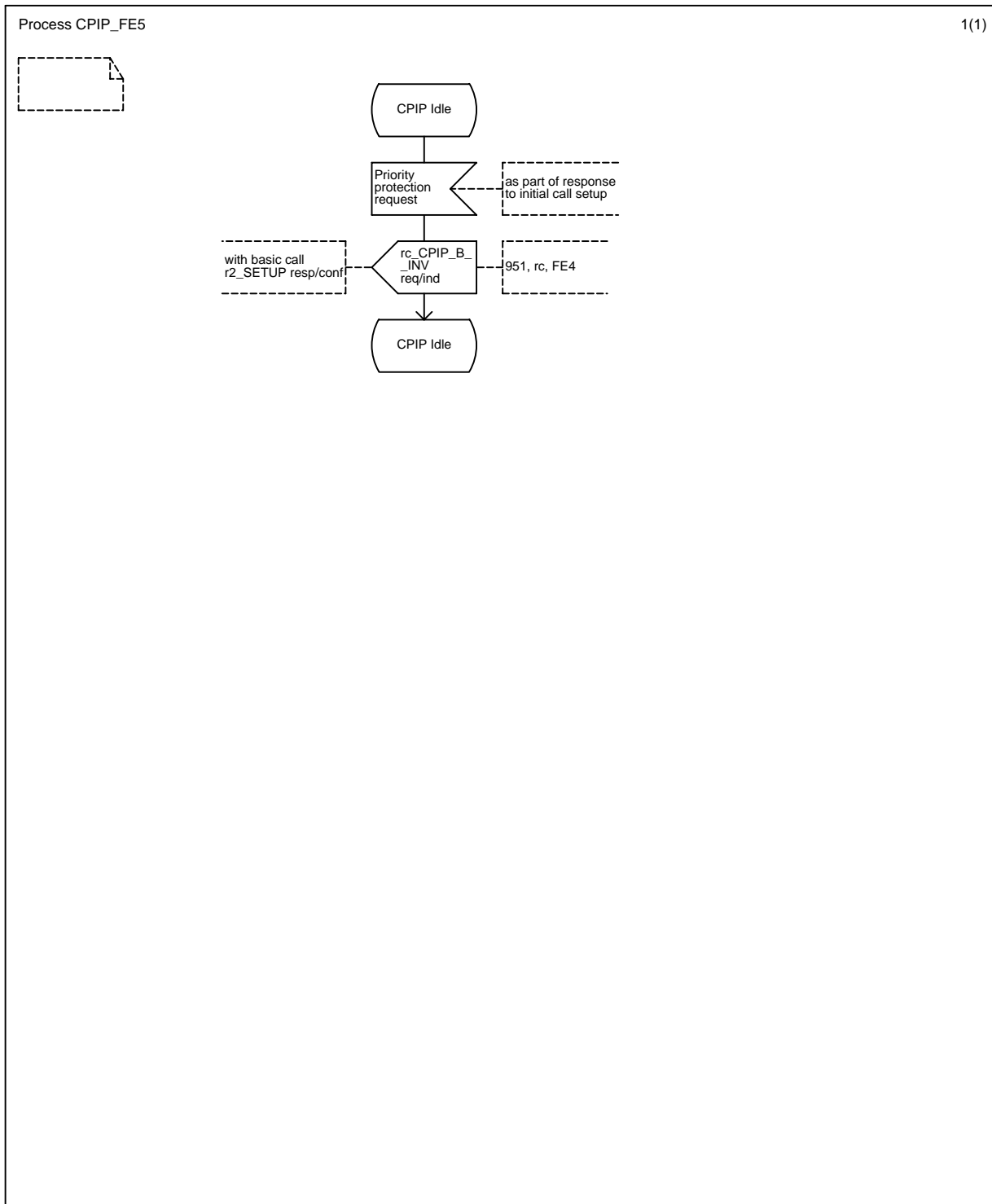

Figure 23 - SS-CPIP, SDL for FE5

9.5 Allocation of Functional Entities to physical equipment

Table 11 shows the allocation of Functional Entities to physical equipment. In this table, TE indicates a TE attached to a PISN. Where a terminal involved is stimulus with respect to SS-CPIP, any TE shown as residing in the corresponding user's TE, shall reside instead in that user's PINX.

Table 11 - Scenarios for the allocation of FEs to physical equipment

Scenario	FE1	FE2	FE3	FE4	FE5
1	Calling user TE	Calling user PINX	Transit PINX	Called user PINX	Called user TE

9.6 Interworking considerations

SS-CPIP applies only to portions of a call that lie within the PISN. For calls to and from other networks the Functional Entities are allocated to physical equipment as shown in table 12.

Table 12 - Scenarios for the allocation of FEs to physical equipment for normal operation in case of interworking with another network

Scenario	FE1	FE2	FE3	FE4	FE5
2	Other N/W	Incoming Gateway PINX	Transit PINX	Called user's PINX	Called user's TE
3	Calling user TE	Calling user PINX	Transit PINX	Outgoing Gateway PINX	Other N/W

Printed copies can be ordered from:

ECMA

114 Rue du Rhône
CH-1204 Geneva
Switzerland

Fax: +41 22 849.60.01

Internet: documents@ecma.ch

Files can be downloaded from our FTP site, [ftp.ecma.ch](ftp://ftp.ecma.ch), logging in as **anonymous** and giving your E-mail address as **password**. This Standard is available from library **ECMA-ST** as a compacted, self-expanding file in MSWord 6.0 format (file E263-DOC.EXE) and as an Acrobat PDF file (file E263-PDF.PDF). File E263-EXP.TXT gives a short presentation of the Standard.

Our web site, <http://www.ecma.ch>, gives full information on ECMA, ECMA activities, ECMA Standards and Technical Reports.

ECMA

**114 Rue du Rhône
CH-1204 Geneva
Switzerland**

This Standard ECMA-263 is available free of charge in printed form and as a file.

See inside cover page for instructions