



Ecma/TC39/2009/038

Final Draft **Standard** ECMA-262

5th Edition / April 2009 - Rev 1/8/09

ECMAScript Language Specification

Standard

Final Draft
Standard
ECMA-262

5th Edition / April 2009

**ECMAScript Language
Specification**

Introduction

This Ecma Standard is based on several originating technologies, the most well known being JavaScript (Netscape) and JScript (Microsoft). The language was invented by Brendan Eich at Netscape and first appeared in that company's Navigator 2.0 browser. It has appeared in all subsequent browsers from Netscape and in all browsers from Microsoft starting with Internet Explorer 3.0.

The development of this Standard started in November 1996. The first edition of this Ecma Standard was adopted by the Ecma General Assembly of June 1997.

That Ecma Standard was submitted to ISO/IEC JTC 1 for adoption under the fast-track procedure, and approved as international standard ISO/IEC 16262, in April 1998. The Ecma General Assembly of June 1998 approved the second edition of ECMA-262 to keep it fully aligned with ISO/IEC 16262. Changes between the first and the second edition are editorial in nature.

The third edition of the Standard introduced powerful regular expressions, better string handling, new control statements, try/catch exception handling, tighter definition of errors, formatting for numeric output and minor changes in anticipation of forthcoming internationalisation facilities and future language growth. The third edition of the ECMAScript standard was adopted by the Ecma General Assembly of December 1999 and published as ISO/IEC 16262:2002 in June 2002.

Since publication of the third edition, ECMAScript has achieved massive adoption in conjunction with the World Wide Web where it has become the programming language that is supported by essentially all web browsers. Significant work was done to develop a fourth edition of ECMAScript. Although that work was not completed and not published¹ as the fourth edition of ECMAScript, it informs continuing evolution of the language. The present fifth edition of ECMAScript (published as ECMA-262 5th edition) codifies de facto interpretations of the language specification that have become common among browser implementations and adds support for new features that have emerged since the publication of the third edition. Such features include accessor properties, reflective creation and inspection of objects, program control of property attributes, additional array manipulation functions, support for the JSON object encoding format, and a strict mode that provides enhanced error checking and program security.

ECMAScript is a vibrant language and the evolution of the language is not complete. Significant technical enhancement will continue with future editions of this specification.

This Ecma Standard has been adopted by the General Assembly of <month> <year>.

¹ Note: Please note that for ECMAScript Edition 4 the Ecma standard number "ECMA-262 Edition 4" was reserved but not used in the Ecma publication process. Therefore "ECMA-262 Edition 4" as an Ecma International publication does not exist.

Table of Contents

| | | |
|----------|----------------------------------|----------|
| 1 | Scope | 1 |
| 2 | Conformance | 1 |
| 3 | References | 1 |
| 4 | Overview | 1 |
| 4.1 | Web Scripting | 2 |
| 4.2 | Language Overview | 2 |
| 4.2.1 | Objects | 2 |
| 4.2.2 | The Strict Variant of ECMAScript | 3 |
| 4.3 | Definitions | 4 |
| 4.3.1 | Type | 4 |
| 4.3.2 | Primitive Value | 4 |
| 4.3.3 | Object | 4 |
| 4.3.4 | Constructor | 4 |
| 4.3.5 | Prototype | 4 |
| 4.3.6 | Native Object | 4 |
| 4.3.7 | Built-in Object | 4 |
| 4.3.8 | Host Object | 5 |
| 4.3.9 | Undefined Value | 5 |
| 4.3.10 | Undefined Type | 5 |
| 4.3.11 | Null Value | 5 |
| 4.3.12 | Null Type | 5 |
| 4.3.13 | Boolean Value | 5 |
| 4.3.14 | Boolean Type | 5 |
| 4.3.15 | Boolean Object | 5 |
| 4.3.16 | String Value | 5 |
| 4.3.17 | String Type | 5 |
| 4.3.18 | String Object | 5 |
| 4.3.19 | Number Value | 5 |
| 4.3.20 | Number Type | 5 |
| 4.3.21 | Number Object | 5 |
| 4.3.22 | Infinity | 6 |
| 4.3.23 | NaN | 6 |
| 4.3.24 | Function | 6 |
| 4.3.25 | Built-in Function | 6 |
| 4.3.26 | Property | 6 |
| 4.3.27 | Method | 6 |
| 4.3.28 | Attribute | 6 |
| 4.3.29 | Own Property | 6 |
| 4.3.30 | Inherited Property | 6 |
| 4.3.31 | Built-in Method | 6 |
| 5 | Notational Conventions | 7 |
| 5.1 | Syntactic and Lexical Grammars | 7 |

| | | |
|----------|---|-----------|
| 5.1.1 | Context-Free Grammars | 7 |
| 5.1.2 | The Lexical and RegExp Grammars | 7 |
| 5.1.3 | The Numeric String Grammar | 7 |
| 5.1.4 | The Syntactic Grammar | 7 |
| 5.1.5 | The JSON Grammar | 8 |
| 5.1.6 | Grammar Notation | 8 |
| 5.2 | Algorithm Conventions | 10 |
| 6 | Source Text | 11 |
| 7 | Lexical Conventions | 12 |
| 7.1 | Unicode Format-Control Characters | 13 |
| 7.2 | White Space | 13 |
| 7.3 | Line Terminators | 14 |
| 7.4 | Comments | 15 |
| 7.5 | Tokens | 16 |
| 7.6 | Identifier Names and Identifiers | 16 |
| 7.6.1 | Reserved Words | 17 |
| 7.7 | Punctuators | 18 |
| 7.8 | Literals | 18 |
| 7.8.1 | Null Literals | 18 |
| 7.8.2 | Boolean Literals | 18 |
| 7.8.3 | Numeric Literals | 19 |
| 7.8.4 | String Literals | 21 |
| 7.8.5 | Regular Expression Literals | 23 |
| 7.9 | Automatic Semicolon Insertion | 24 |
| 7.9.1 | Rules of Automatic Semicolon Insertion | 24 |
| 7.9.2 | Examples of Automatic Semicolon Insertion | 25 |
| 8 | Types | 28 |
| 8.1 | The Undefined Type | 28 |
| 8.2 | The Null Type | 28 |
| 8.3 | The Boolean Type | 28 |
| 8.4 | The String Type | 28 |
| 8.5 | The Number Type | 28 |
| 8.6 | The Object Type | 29 |
| 8.6.1 | Property Attributes | 30 |
| 8.6.2 | Object Internal Properties and Methods | 31 |
| 8.7 | The Reference Specification Type | 34 |
| 8.7.1 | GetValue (V) | 35 |
| 8.7.2 | PutValue (V, W) | 35 |
| 8.8 | The List Specification Type | 36 |
| 8.9 | The Completion Specification Type | 36 |
| 8.10 | The Property Descriptor and Property Identifier Specification Types | 36 |
| 8.10.1 | IsAccessorDescriptor (Desc) | 37 |
| 8.10.2 | IsDataDescriptor (Desc) | 37 |
| 8.10.3 | IsGenericDescriptor (Desc) | 37 |
| 8.10.4 | FromPropertyDescriptor (Desc) | 37 |

| | | |
|-----------|--|-----------|
| 8.10.5 | ToPropertyDescriptor (Obj) | 38 |
| 8.11 | The Lexical Environment and Environment Record Specification Types | 38 |
| 8.12 | Algorithms for Object Internal Methods | 38 |
| 8.12.1 | [[GetOwnProperty]] (P) | 38 |
| 8.12.2 | [[GetProperty]] (P) | 39 |
| 8.12.3 | [[Get]] (P) | 39 |
| 8.12.4 | [[CanPut]] (P) | 39 |
| 8.12.5 | [[Put]] (P, V, Throw) | 39 |
| 8.12.6 | [[HasProperty]] (P) | 40 |
| 8.12.7 | [[Delete]] (P, Throw) | 40 |
| 8.12.8 | [[DefaultValue]] (hint) | 40 |
| 8.12.9 | [[DefineOwnProperty]] (P, Desc, Throw) | 41 |
| 9 | Type Conversion and Testing | 43 |
| 9.1 | ToPrimitive | 43 |
| 9.2 | ToBoolean | 43 |
| 9.3 | ToNumber | 43 |
| 9.3.1 | ToNumber Applied to the String Type | 44 |
| 9.4 | ToInteger | 46 |
| 9.5 | ToInt32: (Signed 32 Bit Integer) | 47 |
| 9.6 | ToUint32: (Unsigned 32 Bit Integer) | 47 |
| 9.7 | ToUint16: (Unsigned 16 Bit Integer) | 47 |
| 9.8 | ToString | 48 |
| 9.8.1 | ToString Applied to the Number Type | 48 |
| 9.9 | ToObject | 49 |
| 9.10 | CheckObjectCoercible | 49 |
| 9.11 | IsCallable | 49 |
| 9.12 | The SameValue Algorithm | 50 |
| 10 | Executable Code and Execution Contexts | 51 |
| 10.1 | Types of Executable Code | 51 |
| 10.1.1 | Strict Mode Code | 51 |
| 10.2 | Lexical Environments | 51 |
| 10.2.1 | Environment Records | 52 |
| 10.2.2 | Lexical Environment Operations | 55 |
| 10.2.3 | The Global Environment | 56 |
| 10.3 | Execution Contexts | 56 |
| 10.3.1 | Identifier Resolution | 57 |
| 10.4 | Establishing an Execution Context | 57 |
| 10.4.1 | Global Code | 57 |
| 10.4.2 | Eval Code | 58 |
| 10.4.3 | Function Code | 58 |
| 10.5 | Declaration Binding Instantiation | 58 |
| 10.6 | Arguments Object | 59 |
| 11 | Expressions | 63 |
| 11.1 | Primary Expressions | 63 |
| 11.1.1 | The this Keyword | 63 |

| | | |
|--------|--|----|
| 11.1.2 | Identifier Reference | 63 |
| 11.1.3 | Literal Reference | 63 |
| 11.1.4 | Array Initialiser | 63 |
| 11.1.5 | Object Initialiser | 64 |
| 11.1.6 | The Grouping Operator | 66 |
| 11.2 | Left-Hand-Side Expressions | 67 |
| 11.2.1 | Property Accessors | 67 |
| 11.2.2 | The new Operator | 68 |
| 11.2.3 | Function Calls | 68 |
| 11.2.4 | Argument Lists | 69 |
| 11.2.5 | Function Expressions | 69 |
| 11.3 | Postfix Expressions | 69 |
| 11.3.1 | Postfix Increment Operator | 69 |
| 11.3.2 | Postfix Decrement Operator | 70 |
| 11.4 | Unary Operators | 70 |
| 11.4.1 | The delete Operator | 70 |
| 11.4.2 | The void Operator | 70 |
| 11.4.3 | The typeof Operator | 71 |
| 11.4.4 | Prefix Increment Operator | 71 |
| 11.4.5 | Prefix Decrement Operator | 71 |
| 11.4.6 | Unary + Operator | 72 |
| 11.4.7 | Unary - Operator | 72 |
| 11.4.8 | Bitwise NOT Operator (~) | 72 |
| 11.4.9 | Logical NOT Operator (!) | 72 |
| 11.5 | Multiplicative Operators | 72 |
| 11.5.1 | Applying the * Operator | 73 |
| 11.5.2 | Applying the / Operator | 73 |
| 11.5.3 | Applying the % Operator | 73 |
| 11.6 | Additive Operators | 74 |
| 11.6.1 | The Addition operator (+) | 74 |
| 11.6.2 | The Subtraction Operator (-) | 74 |
| 11.6.3 | Applying the Additive Operators (+ , -) to Numbers | 75 |
| 11.7 | Bitwise Shift Operators | 75 |
| 11.7.1 | The Left Shift Operator (<<) | 75 |
| 11.7.2 | The Signed Right Shift Operator (>>) | 76 |
| 11.7.3 | The Unsigned Right Shift Operator (>>>) | 76 |
| 11.8 | Relational Operators | 76 |
| 11.8.1 | The Less-than Operator (<) | 77 |
| 11.8.2 | The Greater-than Operator (>) | 77 |
| 11.8.3 | The Less-than-or-equal Operator (<=) | 77 |
| 11.8.4 | The Greater-than-or-equal Operator (>=) | 77 |
| 11.8.5 | The Abstract Relational Comparison Algorithm | 77 |
| 11.8.6 | The instanceof operator | 78 |
| 11.8.7 | The in operator | 78 |
| 11.9 | Equality Operators | 79 |

| | | |
|-----------|--|------------|
| 11.9.1 | The Equals Operator (==) | 79 |
| 11.9.2 | The Does-not-equals Operator (!=) | 79 |
| 11.9.3 | The Abstract Equality Comparison Algorithm | 79 |
| 11.9.4 | The Strict Equals Operator (===) | 80 |
| 11.9.5 | The Strict Does-not-equal Operator (!==) | 81 |
| 11.9.6 | The Strict Equality Comparison Algorithm | 81 |
| 11.10 | Binary Bitwise Operators | 81 |
| 11.11 | Binary Logical Operators | 82 |
| 11.12 | Conditional Operator (? :) | 83 |
| 11.13 | Assignment Operators | 83 |
| 11.13.1 | Simple Assignment (=) | 84 |
| 11.13.2 | Compound Assignment (op=) | 84 |
| 11.14 | Comma Operator (,) | 84 |
| 12 | Statements | 86 |
| 12.1 | Block | 86 |
| 12.2 | Variable statement | 87 |
| 12.2.1 | Strict Mode Restrictions | 88 |
| 12.3 | Empty Statement | 88 |
| 12.4 | Expression Statement | 88 |
| 12.5 | The if Statement | 89 |
| 12.6 | Iteration Statements | 89 |
| 12.6.1 | The do-while Statement | 89 |
| 12.6.2 | The while statement | 89 |
| 12.6.3 | The for Statement | 90 |
| 12.6.4 | The for-in Statement | 90 |
| 12.7 | The continue Statement | 91 |
| 12.8 | The break Statement | 92 |
| 12.9 | The return Statement | 92 |
| 12.10 | The with Statement | 92 |
| 12.10.1 | Strict Mode Restrictions | 93 |
| 12.11 | The switch Statement | 93 |
| 12.12 | Labelled Statements | 95 |
| 12.13 | The throw statement | 95 |
| 12.14 | The try statement | 95 |
| 12.14.1 | Strict Mode Restrictions | 96 |
| 12.15 | Debugger statement | 96 |
| 13 | Function Definition | 98 |
| 13.1 | Strict Mode Restrictions | 99 |
| 13.2 | Creating Function Objects | 99 |
| 13.2.1 | [[Call]] | 100 |
| 13.2.2 | [[Construct]] | 100 |
| 13.2.3 | The [[ThrowTypeError]] Function Object | 100 |
| 14 | Program | 101 |
| 14.1 | Directive Prologues and the Use Strict Directive | 101 |

| | | |
|-----------|---|------------|
| 15 | Standard Built-in ECMAScript Objects | 103 |
| 15.1 | The Global Object | 104 |
| 15.1.1 | Value Properties of the Global Object | 104 |
| 15.1.2 | Function Properties of the Global Object | 104 |
| 15.1.3 | URI Handling Function Properties | 106 |
| 15.1.4 | Constructor Properties of the Global Object | 110 |
| 15.1.5 | Other Properties of the Global Object | 111 |
| 15.2 | Object Objects | 111 |
| 15.2.1 | The Object Constructor Called as a Function | 111 |
| 15.2.2 | The Object Constructor | 111 |
| 15.2.3 | Properties of the Object Constructor | 112 |
| 15.2.4 | Properties of the Object Prototype Object | 114 |
| 15.2.5 | Properties of Object Instances | 116 |
| 15.3 | Function Objects | 116 |
| 15.3.1 | The Function Constructor Called as a Function | 116 |
| 15.3.2 | The Function Constructor | 116 |
| 15.3.3 | Properties of the Function Constructor | 117 |
| 15.3.4 | Properties of the Function Prototype Object | 117 |
| 15.3.5 | Properties of Function Instances | 120 |
| 15.4 | Array Objects | 121 |
| 15.4.1 | The Array Constructor Called as a Function | 121 |
| 15.4.2 | The Array Constructor | 121 |
| 15.4.3 | Properties of the Array Constructor | 122 |
| 15.4.4 | Properties of the Array Prototype Object | 122 |
| 15.4.5 | Properties of Array Instances | 139 |
| 15.5 | String Objects | 140 |
| 15.5.1 | The String Constructor Called as a Function | 140 |
| 15.5.2 | The String Constructor | 140 |
| 15.5.3 | Properties of the String Constructor | 141 |
| 15.5.4 | Properties of the String Prototype Object | 141 |
| 15.5.5 | Properties of String Instances | 150 |
| 15.6 | Boolean Objects | 151 |
| 15.6.1 | The Boolean Constructor Called as a Function | 151 |
| 15.6.2 | The Boolean Constructor | 151 |
| 15.6.3 | Properties of the Boolean Constructor | 151 |
| 15.6.4 | Properties of the Boolean Prototype Object | 151 |
| 15.6.5 | Properties of Boolean Instances | 152 |
| 15.7 | Number Objects | 152 |
| 15.7.1 | The Number Constructor Called as a Function | 152 |
| 15.7.2 | The Number Constructor | 152 |
| 15.7.3 | Properties of the Number Constructor | 152 |
| 15.7.4 | Properties of the Number Prototype Object | 153 |
| 15.7.5 | Properties of Number Instances | 157 |
| 15.8 | The Math Object | 157 |
| 15.8.1 | Value Properties of the Math Object | 157 |
| 15.8.2 | Function Properties of the Math Object | 158 |
| 15.9 | Date Objects | 163 |

| | | |
|----------------|--|------------|
| 15.9.1 | Overview of Date Objects and Definitions of Internal Operators | 163 |
| 15.9.2 | The Date Constructor Called as a Function | 167 |
| 15.9.3 | The Date Constructor | 167 |
| 15.9.4 | Properties of the Date Constructor | 168 |
| 15.9.5 | Properties of the Date Prototype Object | 169 |
| 15.9.6 | Properties of Date Instances | 176 |
| 15.10 | RegExp (Regular Expression) Objects | 176 |
| 15.10.1 | Patterns | 176 |
| 15.10.2 | Pattern Semantics | 178 |
| 15.10.3 | The RegExp Constructor Called as a Function | 190 |
| 15.10.4 | The RegExp Constructor | 190 |
| 15.10.5 | Properties of the RegExp Constructor | 191 |
| 15.10.6 | Properties of the RegExp Prototype Object | 192 |
| 15.10.7 | Properties of RegExp Instances | 193 |
| 15.11 | Error Objects | 194 |
| 15.11.1 | The Error Constructor Called as a Function | 194 |
| 15.11.2 | The Error Constructor | 194 |
| 15.11.3 | Properties of the Error Constructor | 194 |
| 15.11.4 | Properties of the Error Prototype Object | 194 |
| 15.11.5 | Properties of Error Instances | 195 |
| 15.11.6 | Native Error Types Used in This Standard | 195 |
| 15.11.7 | <i>NativeError</i> Object Structure | 196 |
| 15.12 | The JSON Object | 197 |
| 15.12.1 | The JSON Grammar | 197 |
| 15.12.2 | parse (text [, reviver]) | 199 |
| 15.12.3 | stringify (value [, replacer [, space]]) | 200 |
| 16 | Errors | 205 |
| Annex A | | 206 |
| A.1 | Lexical Grammar | 206 |
| A.2 | Number Conversions | 212 |
| A.3 | Expressions | 213 |
| A.4 | Statements | 217 |
| A.5 | Functions and Programs | 219 |
| A.6 | Universal Resource Identifier Character Classes | 220 |
| A.7 | Regular Expressions | 221 |
| A.8 | JSON | 223 |
| A.8.1 | JSON Lexical Grammar | 223 |
| A.8.2 | JSON Syntactic Grammar | 223 |
| Annex B | | 225 |

| | |
|---|------------|
| Compatibility | 225 |
| B.1 Additional Syntax | 225 |
| B.1.1 Numeric Literals | 225 |
| B.1.2 String Literals | 225 |
| B.2 Additional Properties | 226 |
| B.2.1 escape (string) | 226 |
| B.2.2 unescape (string) | 227 |
| B.2.3 String.prototype.substr (start, length) | 228 |
| B.2.4 Date.prototype.getYear () | 228 |
| B.2.5 Date.prototype.setYear (year) | 228 |
| B.2.6 Date.prototype.toGMTString () | 228 |
| Annex C | 230 |
| The Strict Mode of ECMAScript | 230 |
| Annex D | 231 |
| Correction and Clarifications in the 5th Edition with Possible Compatibility Impact | 231 |
| Annex E | 232 |
| Additions and Changes in Edition 5 which Introduce Incompatibilities with Edition 3. | 232 |

1 Scope

This Standard defines the ECMAScript scripting language.

2 Conformance

A conforming implementation of ECMAScript must provide and support all the types, values, objects, properties, functions, and program syntax and semantics described in this specification.

A conforming implementation of this International standard shall interpret characters in conformance with the Unicode Standard, Version 3.0 or later and ISO/IEC 10646-1 with either UCS-2 or UTF-16 as the adopted encoding form, implementation level 3. If the adopted ISO/IEC 10646-1 subset is not otherwise specified, it is presumed to be the BMP subset, collection 300. If the adopted encoding form is not otherwise specified, it is presumed to be the UTF-16 encoding form.

A conforming implementation of ECMAScript is permitted to provide additional types, values, objects, properties, and functions beyond those described in this specification. In particular, a conforming implementation of ECMAScript is permitted to provide properties not described in this specification, and values for those properties, for objects that are described in this specification.

A conforming implementation of ECMAScript is permitted to support program and regular expression syntax not described in this specification. In particular, a conforming implementation of ECMAScript is permitted to support program syntax that makes use of the “future reserved words” listed in 7.5.3 of this specification.

3 References

ISO/IEC 9899:1996 Programming Languages – C, including amendment 1 and technical corrigenda 1 and 2.

ISO/IEC 10646-1:1993 Information Technology -- Universal Multiple-Octet Coded Character Set (UCS) plus its amendments and corrigenda.

The Unicode Consortium. The Unicode Standard, Version 3.0, defined by: The Unicode Standard, Version 3.0 (Boston, MA, Addison-Wesley, 2000. ISBN 0-201-61635-5).

Unicode Inc. (1998), Unicode Technical Report #15: Unicode Normalization Forms.

ANSI/IEEE Std 754-1985: IEEE Standard for Binary Floating-Point Arithmetic. Institute of Electrical and Electronic Engineers, New York (1985).

4 Overview

This section contains a non-normative overview of the ECMAScript language.

ECMAScript is an object-oriented programming language for performing computations and manipulating computational objects within a host environment. ECMAScript as defined here is not intended to be computationally self-sufficient; indeed, there are no provisions in this specification for input of external data or output of computed results. Instead, it is expected that the computational environment of an ECMAScript program will provide not only the objects and other facilities described in this specification but also certain environment-specific *host* objects, whose description and behaviour are beyond the scope of this specification except to indicate that they may provide certain properties that can be accessed and certain functions that can be called from an ECMAScript program.

A *scripting language* is a programming language that is used to manipulate, customise, and automate the facilities of an existing system. In such systems, useful functionality is already available through a user interface, and the scripting language is a mechanism for exposing that functionality to program control. In this way, the existing system is said to provide a host environment of objects and facilities, which completes the capabilities of the scripting language. A scripting language is intended for use by both professional and non-professional programmers.

ECMAScript was originally designed to be a *Web scripting language*, providing a mechanism to enliven Web pages in browsers and to perform server computation as part of a Web-based client-server architecture. ECMAScript can provide core scripting capabilities for a variety of host environments, and therefore the core scripting language is specified in this document apart from any particular host environment.

Some of the facilities of ECMAScript are similar to those used in other programming languages; in particular Java™, Self, and Scheme as described in:

- Gosling, James, Bill Joy and Guy Steele. The Java™ Language Specification. Addison Wesley Publishing Co., 1996.
- Ungar, David, and Smith, Randall B. Self: The Power of Simplicity. OOPSLA '87 Conference Proceedings, pp. 227–241, Orlando, FL, October 1987.
- IEEE Standard for the Scheme Programming Language. IEEE Std 1178-1990.

4.1 Web Scripting

A web browser provides an ECMAScript host environment for client-side computation including, for instance, objects that represent windows, menus, pop-ups, dialog boxes, text areas, anchors, frames, history, cookies, and input/output. Further, the host environment provides a means to attach scripting code to events such as change of focus, page and image loading, unloading, error and abort, selection, form submission, and mouse actions. Scripting code appears within the HTML and the displayed page is a combination of user interface elements and fixed and computed text and images. The scripting code is reactive to user interaction and there is no need for a main program.

A web server provides a different host environment for server-side computation including objects representing requests, clients, and files; and mechanisms to lock and share data. By using browser-side and server-side scripting together, it is possible to distribute computation between the client and server while providing a customised user interface for a Web-based application.

Each Web browser and server that supports ECMAScript supplies its own host environment, completing the ECMAScript execution environment.

4.2 Language Overview

The following is an informal overview of ECMAScript—not all parts of the language are described. This overview is not part of the standard proper.

ECMAScript is object-based: basic language and host facilities are provided by objects, and an ECMAScript program is a cluster of communicating objects. An ECMAScript *object* is a collection of *properties* each with zero or more *attributes* that determine how each property can be used—for example, when the Writable attribute for a property is set to **false**, any attempt by executed ECMAScript code to change the value of the property fails. Properties are containers that hold other objects, *primitive values*, or *functions*. A primitive value is a member of one of the following built-in types: **Undefined**, **Null**, **Boolean**, **Number**, and **String**; an object is a member of the remaining built-in type **Object**; and a function is a callable object. A function that is associated with an object via a property is a *method*.

ECMAScript defines a collection of *built-in objects* that round out the definition of ECMAScript entities. These built-in objects include the **Global** object, the **Object** object, the **Function** object, the **Array** object, the **String** object, the **Boolean** object, the **Number** object, the **Math** object, the **Date** object, the **RegExp** object, the **JSON** object, and the Error objects **Error**, **EvalError**, **RangeError**, **ReferenceError**, **SyntaxError**, **TypeError** and **URIError**.

ECMAScript also defines a set of built-in *operators*. ECMAScript operators include various unary operations, multiplicative operators, additive operators, bitwise shift operators, relational operators, equality operators, binary bitwise operators, binary logical operators, assignment operators, and the comma operator.

ECMAScript syntax intentionally resembles Java syntax. ECMAScript syntax is relaxed to enable it to serve as an easy-to-use scripting language. For example, a variable is not required to have its type declared nor are types associated with properties, and defined functions are not required to have their declarations appear textually before calls to them.

4.2.1 Objects

ECMAScript does not use classes such as those in C++, Smalltalk, or Java. Instead objects may be created in various ways including via a literal notation or via *constructors* which create objects and then execute code that initialises all or part of them by assigning initial values to their properties. Each constructor is a function that has a property named “prototype” that is used to implement *prototype-*

based inheritance and **shared properties**. Objects are created by using constructors in **new** expressions; for example, `new Date(2009,11)` creates a new `Date` object. Invoking a constructor without using **new** has consequences that depend on the constructor. For example, `Date()` produces a string representation of the current date and time rather than an object.

ECMAScript supports *prototype-based inheritance*. Every object created by a constructor has an implicit reference (called the *object's prototype*) to the value of its constructor's "prototype" property. Furthermore, a prototype may have a non-null implicit reference to its prototype, and so on; this is called the *prototype chain*. When a reference is made to a property in an object, that reference is to the property of that name in the first object in the prototype chain that contains a property of that name. In other words, first the object mentioned directly is examined for such a property; if that object contains the named property, that is the property to which the reference refers; if that object does not contain the named property, the prototype for that object is examined next; and so on.

In a class-based object-oriented language, in general, state is carried by instances, methods are carried by classes, and inheritance is only of structure and behaviour. In ECMAScript, the state and methods are carried by objects, and structure, behaviour, and state are all inherited.

All objects that do not directly contain a particular property that their prototype contains share that property and its value. The following diagram illustrates this:

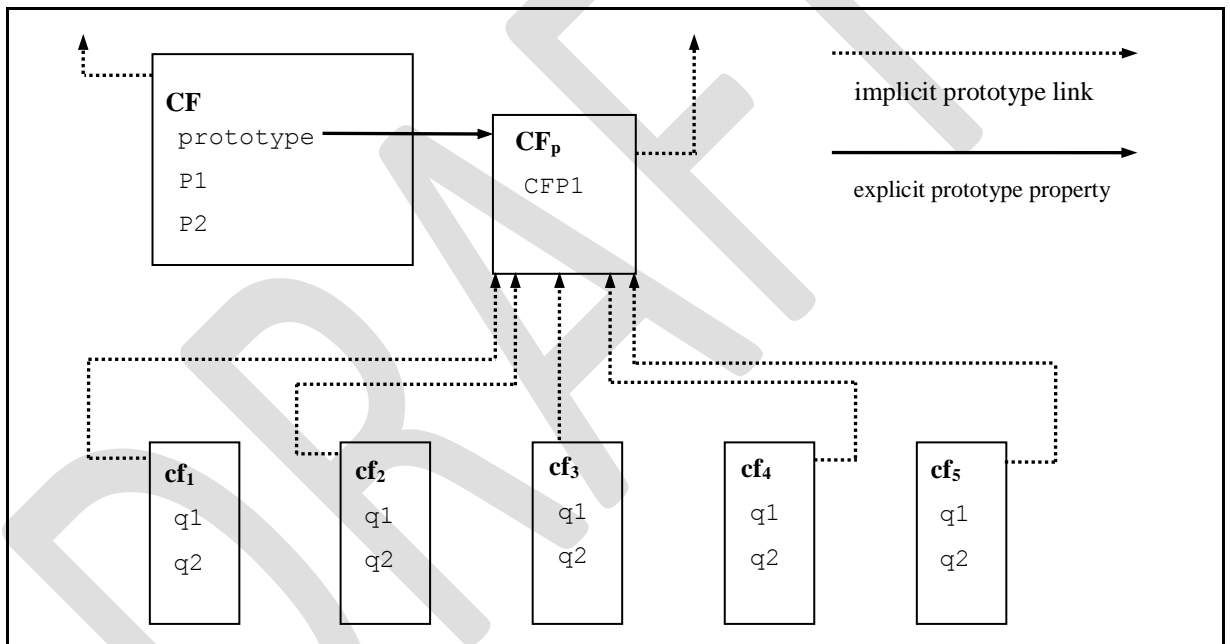

CF is a constructor (and also an object). Five objects have been created by using **new** expressions: **cf₁**, **cf₂**, **cf₃**, **cf₄**, and **cf₅**. Each of these objects contains properties named `q1` and `q2`. The dashed lines represent the implicit prototype relationship; so, for example, **cf₃**'s prototype is **CF_p**. The constructor, **CF**, has two properties itself, named `P1` and `P2`, which are not visible to **CF_p**, **cf₁**, **cf₂**, **cf₃**, **cf₄**, or **cf₅**. The property named `CFP1` in **CF_p** is shared by **cf₁**, **cf₂**, **cf₃**, **cf₄**, and **cf₅** (but not by **CF**), as are any properties found in **CF_p**'s implicit prototype chain that are not named `q1`, `q2`, or `CFP1`. Notice that there is no implicit prototype link between **CF** and **CF_p**.

Unlike class-based object languages, properties can be added to objects dynamically by assigning values to them. That is, constructors are not required to name or assign values to all or any of the constructed object's properties. In the above diagram, one could add a new shared property for **cf₁**, **cf₂**, **cf₃**, **cf₄**, and **cf₅** by assigning a new value to the property in **CF_p**.

4.2.2 The Strict Variant of ECMAScript

The ECMAScript Language recognizes the possibility that some users of the language may wish to restrict their usage of some features available in the language. They might do so in the interests of security, to avoid what they consider to be error prone features, to get enhanced error checking, or for

other reasons of their choosing. In support of this possibility, ECMAScript defines a strict variant of the language. The strict variant of the language excludes some specific syntactic and semantic features of the regular ECMAScript language and modifies the detailed semantics of some features. The strict variant also specifies additional error conditions that must be reported by throwing error exceptions in situations that are not specified as errors by the non-strict form of the language.

The strict variant of ECMAScript is commonly referred to as the *strict mode* of the language. Strict mode selection and use of the strict mode syntax and semantics of ECMAScript is explicitly made at the level of individual ECMAScript code units. Because strict mode is selected at the level of a syntactic code unit, strict mode only imposes restrictions that have local effect within such a code unit. Strict mode does not restrict or modify any aspect of the ECMAScript semantics that must operate consistently across multiple code units. A complete ECMAScript program may be composed for both strict mode and non-strict mode ECMAScript code units. In this case, strict mode only applies when actually executing code that is defined within a strict mode code unit.

In order to conform to this specification, an ECMAScript implementation must implement both the full unrestricted ECMAScript language and the strict mode variant of the ECMAScript language as defined by this specification. In addition, an implementation must support the combination of unrestricted and strict mode code units into a single composite program.

4.3 Definitions

The following are informal definitions of key terms associated with ECMAScript.

4.3.1 Type

A *type* is a set of data values as defined in section 8 of this specification.

4.3.2 Primitive Value

A *primitive value* is a member of one of the types **Undefined**, **Null**, **Boolean**, **Number**, or **String**. A primitive value is a datum that is represented directly at the lowest level of the language implementation.

4.3.3 Object

An *object* is a member of the type **Object**. It is a collection of properties.

4.3.4 Constructor

A *constructor* is a Function object that creates and initialises objects. The value of a constructor's "prototype" property is a prototype object that is used to implement inheritance and shared properties.

4.3.5 Prototype

A *prototype* is an object used to implement structure, state, and behaviour inheritance in ECMAScript. When a constructor creates an object, that object implicitly references the constructor's "prototype" property for the purpose of resolving property references. The constructor's "prototype" property can be referenced by the program expression `constructor.prototype`, and properties added to an object's prototype are shared, through inheritance, by all objects sharing the prototype. Alternatively, a new object may be created with an explicitly specified prototype by using the `Object.create` built-in function.

4.3.6 Native Object

A *native object* is any object in an ECMAScript implementation whose semantics are fully defined by this specification rather than by the host environment. Standard native objects are defined in this specification. Some native objects are built-in; others may be constructed during the course of execution of an ECMAScript program.

4.3.7 Built-in Object

A *built-in object* is any object supplied by an ECMAScript implementation, independent of the host environment, which is present at the start of the execution of an ECMAScript program. Standard built-in objects are defined in this specification, and an ECMAScript implementation may specify and define others. Every built-in object is a native object. A *built-in constructor* is a built-in object that is also a constructor.

4.3.8 Host Object

A *host object* is any object supplied by the host environment to complete the execution environment of ECMAScript. Any object that is not native is a host object.

4.3.9 Undefined Value

The *undefined value* is a primitive value used when a variable has not been assigned a value.

4.3.10 Undefined Type

The type **Undefined** has exactly one value, called **undefined**.

4.3.11 Null Value

The *null value* is a primitive value that represents the intentional absence of any other value.

4.3.12 Null Type

The type **Null** has exactly one value, called **null**.

4.3.13 Boolean Value

A *boolean value* is a primitive value that is a member of the type **Boolean** and is one of two unique values, **true** and **false**.

4.3.14 Boolean Type

The type **Boolean** represents a logical entity and consists of exactly two unique values. One is called **true** and the other is called **false**.

4.3.15 Boolean Object

A *Boolean object* is a member of the type **Object** and is an instance of the standard built-in Boolean constructor. That is, a Boolean object is created by using the Boolean constructor in a **new** expression, supplying a boolean value as an argument. The resulting object has an implicit (unnamed) property that is the boolean value. A Boolean object can be coerced to a boolean value.

4.3.16 String Value

A *string value* is a primitive value that is a member of the type **String** and is a finite ordered sequence of zero or more 16-bit unsigned integer values.

NOTE

Although each value usually represents a single 16-bit unit of UTF-16 text, the language does not place any restrictions or requirements on the values except that they must be 16-bit unsigned integers.

4.3.17 String Type

The type **String** is the set of all string values.

4.3.18 String Object

A *String object* is a member of the type **Object** and is an instance of the standard built-in String constructor. That is, a String object is created by using the String constructor in a **new** expression, supplying a string as an argument. The resulting object has an implicit (unnamed) property that is the string. A String object can be coerced to a string value by calling the String constructor as a function (15.5.1).

4.3.19 Number Value

A *number value* is a primitive value that is a member of the type **Number** and is a direct representation of a number.

4.3.20 Number Type

The type **Number** is a set of primitive values representing numbers. In ECMAScript, the set of values represents the double-precision 64-bit format IEEE 754 values including the special “Not-a-Number” (NaN) values, positive infinity, and negative infinity.

4.3.21 Number Object

A *Number object* is a member of the type **Object** and is an instance of the standard built-in Number constructor. That is, a Number object is created by using the Number constructor in a **new** expression,

supplying a number as an argument. The resulting object has an implicit (unnamed) property that is the number. A Number object can be coerced to a number value by calling the Number constructor as a function (15.7.1).

4.3.22 **Infinity**

The primitive value **Infinity** represents the positive infinite number value. This value is a member of the Number type.

4.3.23 **NaN**

The primitive value **NaN** represents the set of IEEE 754 “Not-a-Number” values. This value is a member of the Number type.

4.3.24 **Function**

A *function* is a member of the type **Object** that may be invoked as a subroutine. In addition to its named properties, a function contains executable code and state that determine how it behaves when invoked. A function’s code may or may not be written in ECMAScript.

4.3.25 **Built-in Function**

A built-in function is a native function that is a built-in object of the language, such as **parseInt** and **Math.exp**. An implementation may also provide implementation-dependent built-in functions that are not described in this specification.

4.3.26 **Property**

A *property* is an association between a name and a value that is part of an object. Depending upon the form of the property the value may be represented either directly as a data value (a primitive value, an object, or a function object) or indirectly by a pair of accessor functions.

4.3.27 **Method**

A *method* is a function that is the value of a property. When a function is called as a method of an object, the object is passed to the function as its **this** value.

4.3.28 **Attribute**

An *attribute* is an internal value that defines some characteristic of a property.

4.3.29 **Own Property**

An own property of an object is a property that is directly present on that object.

4.3.30 **Inherited Property**

An *inherited property* is a property of an object that is not one of its own properties but is a property (either own or inherited) of the object’s prototype.

4.3.31 **Built-in Method**

A *built-in method* is any method that is a built-in function. Standard built-in methods are defined in this specification, and an ECMAScript implementation may specify and define others. A built-in method is a Built-in function.

5 Notational Conventions

5.1 Syntactic and Lexical Grammars

This section describes the context-free grammars used in this specification to define the lexical and syntactic structure of an ECMAScript program.

5.1.1 Context-Free Grammars

A *context-free grammar* consists of a number of *productions*. Each production has an abstract symbol called a *nonterminal* as its *left-hand side*, and a sequence of zero or more nonterminal and *terminal* symbols as its *right-hand side*. For each grammar, the terminal symbols are drawn from a specified alphabet.

Starting from a sentence consisting of a single distinguished nonterminal, called the *goal symbol*, a given context-free grammar specifies a *language*, namely, the (perhaps infinite) set of possible sequences of terminal symbols that can result from repeatedly replacing any nonterminal in the sequence with a right-hand side of a production for which the nonterminal is the left-hand side.

5.1.2 The Lexical and RegExp Grammars

A *lexical grammar* for ECMAScript is given in clause 7. This grammar has as its terminal symbols characters (Unicode code units) that conform to the rules for *SourceCharacter* defined in section 6. It defines a set of productions, starting from the goal symbol *InputElementDiv* or *InputElementRegExp*, that describe how sequences of such characters are translated into a sequence of input elements.

Input elements other than white space and comments form the terminal symbols for the syntactic grammar for ECMAScript and are called ECMAScript *tokens*. These tokens are the reserved words, identifiers, literals, and punctuators of the ECMAScript language. Moreover, line terminators, although not considered to be tokens, also become part of the stream of input elements and guide the process of automatic semicolon insertion (7.9). Simple white space and single-line comments are discarded and do not appear in the stream of input elements for the syntactic grammar. A *MultiLineComment* (that is, a comment of the form “/*...*/” regardless of whether it spans more than one line) is likewise simply discarded if it contains no line terminator; but if a *MultiLineComment* contains one or more line terminators, then it is replaced by a single line terminator, which becomes part of the stream of input elements for the syntactic grammar.

A *RegExp grammar* for ECMAScript is given in 15.10. This grammar also has as its terminal symbols the characters as defined by *SourceCharacter*. It defines a set of productions, starting from the goal symbol *Pattern*, that describe how sequences of characters are translated into regular expression patterns.

Productions of the lexical and RegExp grammars are distinguished by having two colons “: :” as separating punctuation. The lexical and RegExp grammars share some productions.

5.1.3 The Numeric String Grammar

A second grammar is used for translating strings into numeric values. This grammar is similar to the part of the lexical grammar having to do with numeric literals and has as its terminal symbols *SourceCharacter*. This grammar appears in 9.3.1.

Productions of the numeric string grammar are distinguished by having three colons “: : :” as punctuation.

5.1.4 The Syntactic Grammar

The *syntactic grammar* for ECMAScript is given in clauses 11, 12, 13 and 14. This grammar has ECMAScript tokens defined by the lexical grammar as its terminal symbols (5.1.2). It defines a set of productions, starting from the goal symbol *Program*, that describe how sequences of tokens can form syntactically correct ECMAScript programs.

When a stream of characters is to be parsed as an ECMAScript program, it is first converted to a stream of input elements by repeated application of the lexical grammar; this stream of input elements is then parsed by a single application of the syntax grammar. The program is syntactically in error if the tokens in the stream of input elements cannot be parsed as a single instance of the goal nonterminal *Program*, with no tokens left over.

Productions of the syntactic grammar are distinguished by having just one colon “:” as punctuation.

The syntactic grammar as presented in sections 11, 12, 13 and 14 is actually not a complete account of which token sequences are accepted as correct ECMAScript programs. Certain additional token sequences are also accepted, namely, those that would be described by the grammar if only semicolons were added to the sequence in certain places (such as before line terminator characters). Furthermore, certain token sequences that are described by the grammar are not considered acceptable if a terminator character appears in certain “awkward” places.

5.1.5 The JSON Grammar

The JSON grammar is used to translate a string describing a set of ECMAScript objects into actual objects. The JSON grammar is given in 15.12.1.

The JSON grammar consists of the JSON lexical grammar and the JSON syntactic grammar. The JSON lexical grammar is used to translate character sequences into tokens and is similar to parts of the ECMAScript lexical grammar. The JSON syntactic grammar describes how sequences of tokens from the JSON lexical grammar can form syntactically correct JSON object descriptions.

Productions of the JSON lexical grammar are distinguished by having two colons “::” as separating punctuation. The JSON lexical grammar uses some productions from the ECMAScript lexical grammar. The JSON syntactic grammar is similar to parts of the ECMAScript syntactic grammar. Productions of the JSON syntactic grammar are distinguished by using one colon “:” as separating punctuation.

5.1.6 Grammar Notation

Terminal symbols of the lexical and string grammars, and some of the terminal symbols of the syntactic grammar, are shown in **fixed width** font, both in the productions of the grammars and throughout this specification whenever the text directly refers to such a terminal symbol. These are to appear in a program exactly as written. All terminal symbol characters specified in this way are to be understood as the appropriate Unicode character from the ASCII range, as opposed to any similar-looking characters from other Unicode ranges.

Nonterminal symbols are shown in *italic* type. The definition of a nonterminal is introduced by the name of the nonterminal being defined followed by one or more colons. (The number of colons indicates to which grammar the production belongs.) One or more alternative right-hand sides for the nonterminal then follow on succeeding lines. For example, the syntactic definition:

WhileStatement :

while (*Expression*) *Statement*

states that the nonterminal *WhileStatement* represents the token **while**, followed by a left parenthesis token, followed by an *Expression*, followed by a right parenthesis token, followed by a *Statement*. The occurrences of *Expression* and *Statement* are themselves nonterminals. As another example, the syntactic definition:

ArgumentList :

AssignmentExpression
ArgumentList , *AssignmentExpression*

states that an *ArgumentList* may represent either a single *AssignmentExpression* or an *ArgumentList*, followed by a comma, followed by an *AssignmentExpression*. This definition of *ArgumentList* is *recursive*, that is, it is defined in terms of itself. The result is that an *ArgumentList* may contain any positive number of arguments, separated by commas, where each argument expression is an *AssignmentExpression*. Such recursive definitions of nonterminals are common.

The subscripted suffix “*opt*”, which may appear after a terminal or nonterminal, indicates an *optional symbol*. The alternative containing the optional symbol actually specifies two right-hand sides, one that omits the optional element and one that includes it. This means that:

VariableDeclaration :

*Identifier Initialiser*_{*opt*}

is a convenient abbreviation for:

VariableDeclaration :

Identifier

Identifier Initialiser

and that:

IterationStatement :

for (*ExpressionNoIn_{opt}* ; *Expression_{opt}* ; *Expression_{opt}*) *Statement*

is a convenient abbreviation for:

IterationStatement :

for (; *Expression_{opt}* ; *Expression_{opt}*) *Statement*

for (*ExpressionNoIn* ; *Expression_{opt}* ; *Expression_{opt}*) *Statement*

which in turn is an abbreviation for:

IterationStatement :

for (; ; *Expression_{opt}*) *Statement*

for (; *Expression* ; *Expression_{opt}*) *Statement*

for (*ExpressionNoIn* ; ; *Expression_{opt}*) *Statement*

for (*ExpressionNoIn* ; *Expression* ; *Expression_{opt}*) *Statement*

which in turn is an abbreviation for:

IterationStatement :

for (; ;) *Statement*

for (; ; *Expression*) *Statement*

for (; *Expression* ;) *Statement*

for (; *Expression* ; *Expression*) *Statement*

for (*ExpressionNoIn* ; ;) *Statement*

for (*ExpressionNoIn* ; ; *Expression*) *Statement*

for (*ExpressionNoIn* ; *Expression* ;) *Statement*

for (*ExpressionNoIn* ; *Expression* ; *Expression*) *Statement*

so the nonterminal *IterationStatement* actually has eight alternative right-hand sides.

If the phrase “[empty]” appears as the right-hand side of a production, it indicates that the production's right-hand side contains no terminals or nonterminals.

If the phrase “[lookahead \notin *set*]” appears in the right-hand side of a production, it indicates that the production may not be used if the immediately following input token is a member of the given *set*. The *set* can be written as a list of terminals enclosed in curly braces. For convenience, the set can also be written as a nonterminal, in which case it represents the set of all terminals to which that nonterminal could expand. For example, given the definitions

DecimalDigit :: **one of**

0 1 2 3 4 5 6 7 8 9

DecimalDigits ::

DecimalDigit

DecimalDigits *DecimalDigit*

the definition

LookaheadExample ::

n [lookahead \notin {1, 3, 5, 7, 9}] *DecimalDigits*

DecimalDigit [lookahead \notin *DecimalDigit*]

matches either the letter **n** followed by one or more decimal digits the first of which is even, or a decimal digit not followed by another decimal digit.

If the phrase “[no *LineTerminator* here]” appears in the right-hand side of a production of the syntactic grammar, it indicates that the production is a *restricted production*: it may not be used if a *LineTerminator* occurs in the input stream at the indicated position. For example, the production:

ReturnStatement :

return [no *LineTerminator* here] *Expression*_{opt} ;

indicates that the production may not be used if a *LineTerminator* occurs in the program between the **return** token and the *Expression*.

Unless the presence of a *LineTerminator* is forbidden by a restricted production, any number of occurrences of *LineTerminator* may appear between any two consecutive tokens in the stream of input elements without affecting the syntactic acceptability of the program.

When the words “**one of**” follow the colon(s) in a grammar definition, they signify that each of the terminal symbols on the following line or lines is an alternative definition. For example, the lexical grammar for ECMAScript contains the production:

NonZeroDigit :: **one of**

1 2 3 4 5 6 7 8 9

which is merely a convenient abbreviation for:

NonZeroDigit ::

1
2
3
4
5
6
7
8
9

When an alternative in a production of the lexical grammar or the numeric string grammar appears to be a multi-character token, it represents the sequence of characters that would make up such a token.

The right-hand side of a production may specify that certain expansions are not permitted by using the phrase “**but not**” and then indicating the expansions to be excluded. For example, the production:

Identifier ::

IdentifierName **but not** *ReservedWord*

means that the nonterminal *Identifier* may be replaced by any sequence of characters that could replace *IdentifierName* provided that the same sequence of characters could not replace *ReservedWord*.

Finally, a few nonterminal symbols are described by a descriptive phrase in roman type in cases where it would be impractical to list all the alternatives:

SourceCharacter ::

any Unicode code unit

5.2 Algorithm Conventions

The specification often uses a numbered list to specify steps in an algorithm. These algorithms are used to precisely specify the required semantics of ECMAScript language constructs. The algorithms are not intended to imply the use of any specific implementation technique. In practice, there may be more efficient algorithms available to implement a given feature.

In order to facilitate their use in multiple parts of this specification, some algorithms, called *abstract operations*, are named and written in parameterized functional form so that they may be referenced by name from within other algorithms.

When an algorithm is to produce a value as a result, the directive “return x ” is used to indicate that the result of the algorithm is the value of x and that the algorithm should terminate. The notation $\text{Result}(n)$ is used as shorthand for “the result of step n ”.

For clarity of expression, algorithm steps may be subdivided into sequential substeps. Substeps are indented and may themselves be further divided into indented substeps. Outline numbering conventions are used to identify substeps with the first level of substeps labelled with lower case alphabetic characters and the second level of substeps labelled with lower case roman numerals. If more than three levels are required these rules repeat with the fourth level using numeric labels. For example:

1. Top-level step
 - a. Substep.
 - b. Substep
 - i. Subsubstep.
 - ii. Subsubstep.
 1. Subsubsubstep
 - a. Subsubsubsubstep

A step or substep may be written as an “if” predicate that conditions its substeps. In this case, the substeps are only applied if the predicate is true. If a step or substep begins with the word “else”, it is a predicate that is the negation of the preceding “if” predicate step at the same level.

A step may specify the iterative application of its substeps.

Mathematical operations such as addition, subtraction, negation, multiplication, division, and the mathematical functions defined later in this section should always be understood as computing exact mathematical results on mathematical real numbers, which do not include infinities and do not include a negative zero that is distinguished from positive zero. Algorithms in this standard that model floating-point arithmetic include explicit steps, where necessary, to handle infinities and signed zero and to perform rounding. If a mathematical operation or function is applied to a floating-point number, it should be understood as being applied to the exact mathematical value represented by that floating-point number; such a floating-point number must be finite, and if it is $+0$ or -0 then the corresponding mathematical value is simply 0.

The mathematical function $\text{abs}(x)$ yields the absolute value of x , which is $-x$ if x is negative (less than zero) and otherwise is x itself.

The mathematical function $\text{sign}(x)$ yields 1 if x is positive and -1 if x is negative. The sign function is not used in this standard for cases when x is zero.

The notation “ x modulo y ” (y must be finite and nonzero) computes a value k of the same sign as y (or zero) such that $\text{abs}(k) < \text{abs}(y)$ and $x - k = q \times y$ for some integer q .

The mathematical function $\text{floor}(x)$ yields the largest integer (closest to positive infinity) that is not larger than x .

NOTE

$\text{floor}(x) = x - (x \text{ modulo } 1)$.

If an algorithm is defined to “throw an exception”, execution of the algorithm is terminated and no result is returned. The calling algorithms are also terminated, until an algorithm step is reached that explicitly deals with the exception, using terminology such as “If an exception was thrown...”. Once such an algorithm step has been encountered the exception is no longer considered to have occurred.

6 Source Text

ECMAScript source text is represented as a sequence of characters in the Unicode character encoding, version 3.0 or later. The text is expected to have been normalised to Unicode Normalised Form C (canonical composition), as described in Unicode Technical Report #15. Conforming ECMAScript implementations are not required to perform any normalisation of text, or behave as though they were performing normalisation of text, themselves. ECMAScript source text is assumed to be a sequence of 16-bit code units for the purposes of this specification. Such a source text may include sequences of 16-bit code units that are not valid UTF-16

character encodings. If an actual source text is encoded in a form other than 16-bit code units it must be processed as if it was first convert to UTF-16.

SourceCharacter ::

any Unicode code unit

Throughout the rest of this document, the phrase “code unit” and the word “character” will be used to refer to a 16-bit unsigned value used to represent a single 16-bit unit of text. The phrase “Unicode character” will be used to refer to the abstract linguistic or typographical unit represented by a single Unicode scalar value (which may be longer than 16 bits and thus may be represented by more than one code unit). The phrase “code point” refers to such a Unicode scalar value. “Unicode character” only refers to entities represented by single Unicode scalar values: the components of a combining character sequence are still individual “Unicode characters,” even though a user might think of the whole sequence as a single character.

In string literals, regular expression literals, and identifiers, any character (code unit) may also be expressed as a Unicode escape sequence consisting of six characters, namely `\u` plus four hexadecimal digits. Within a comment, such an escape sequence is effectively ignored as part of the comment. Within a string literal or regular expression literal, the Unicode escape sequence contributes one character to the value of the literal. Within an identifier, the escape sequence contributes one character to the identifier.

NOTE

Although this document sometimes refers to a “transformation” between a “character” within a “string” and the 16-bit unsigned integer that is the code unit of that character, there is actually no transformation because a “character” within a “string” is actually represented using that 16-bit unsigned value.

ECMAScript differs from the Java programming language in the behaviour of Unicode escape sequences. In a Java program, if the Unicode escape sequence `\u000A`, for example, occurs within a single-line comment, it is interpreted as a line terminator (Unicode character `000A` is line feed) and therefore the next character is not part of the comment. Similarly, if the Unicode escape sequence `\u000A` occurs within a string literal in a Java program, it is likewise interpreted as a line terminator, which is not allowed within a string literal—one must write `\n` instead of `\u000A` to cause a line feed to be part of the string value of a string literal. In an ECMAScript program, a Unicode escape sequence occurring within a comment is never interpreted and therefore cannot contribute to termination of the comment. Similarly, a Unicode escape sequence occurring within a string literal in an ECMAScript program always contributes a character to the string value of the literal and is never interpreted as a line terminator or as a quote mark that might terminate the string literal.

7 Lexical Conventions

The source text of an ECMAScript program is first converted into a sequence of input elements, which are tokens, line terminators, comments, or white space. The source text is scanned from left to right, repeatedly taking the longest possible sequence of characters as the next input element.

There are two goal symbols for the lexical grammar. The *InputElementDiv* symbol is used in those syntactic grammar contexts where a leading division (`/`) or division-assignment (`/=`) operator is permitted. The *InputElementRegExp* symbol is used in other syntactic grammar contexts.

NOTE

There are no syntactic grammar contexts where both a leading division or division-assignment, and a leading RegularExpressionLiteral are permitted. This is not affected by semicolon insertion (section 7.9); in examples such as the following:

```
a = b
/hi/g.exec(c).map(d);
```

where the first non-whitespace, non-comment character after a LineTerminator is slash (`/`) and the syntactic context allows division or division-assignment, no semicolon is inserted at the LineTerminator. That is, the above example is interpreted in the same way as:

```
a = b / hi / g.exec(c).map(d);
```

As a workaround, one may enclose the regular expression literal in parentheses.

Syntax

InputElementDiv ::

WhiteSpace
LineTerminator
Comment
Token
DivPunctuator

InputElementRegExp ::

WhiteSpace
LineTerminator
Comment
Token
RegularExpressionLiteral

7.1 Unicode Format-Control Characters

The Unicode format-control characters (i.e., the characters in category “Cf” in the Unicode Character Database such as LEFT-TO-RIGHT MARK or RIGHT-TO-LEFT MARK) are control codes used to control the formatting of a range of text in the absence of higher-level protocols for this (such as mark-up languages).

It is useful to allow format-control characters in source text to facilitate editing and display. All format control characters may be used in within comments, and within string literals and regular expression literals.

<ZWJ> and <ZWNJ> are format control characters that are used to make necessary distinctions when forming words or phrases in certain languages. In ECMAScript source text, <ZWJ> and <ZWNJ> may also be used in an identifier after the first character.

<BOM> is a format-control character used primarily at the start of a text to mark it as Unicode and to allow detection of the text's encoding and byte order. <BOM> characters intended for this purpose can sometimes also appear after the start of a text, for example as a result of concatenating files. <ZWSP> is a format-control character used for line break control when justifying text. In ECMAScript source text, <ZWSP> and <BOM> characters are treated as white space characters (7.2).

The following format-control characters have special treatment outside of comments, string literals, and regular expression literals:

| <i>Code Unit Value</i> | <i>Name</i> | <i>Formal Name</i> | <i>Usage</i> |
|------------------------|-----------------------|--------------------|-----------------------|
| <code>\u200B</code> | Zero width space | <ZWSP> | <i>Whitespace</i> |
| <code>\u200C</code> | Zero width non-joiner | <ZWNJ> | <i>IdentifierPart</i> |
| <code>\u200D</code> | Zero width joiner | <ZWJ> | <i>IdentifierPart</i> |
| <code>\uFEFF</code> | Byte Order Mark | <BOM> | <i>Whitespace</i> |

7.2 White Space

1. White space characters are used to improve source text readability and to separate tokens (indivisible lexical units) from each other, but are otherwise insignificant. White space characters may occur between any two tokens, and may occur within a *StringLiteral* or a *RegularExpressionLiteral* (where they are considered significant characters forming part of the literal value) or within a *Comment*, but cannot appear within any other kind of token.

The following characters are considered to be white space:

| <i>Code Unit Value</i> | <i>Name</i> | <i>Formal Name</i> |
|------------------------|--|--------------------|
| <code>\u0009</code> | Tab | <TAB> |
| <code>\u000B</code> | Vertical Tab | <VT> |
| <code>\u000C</code> | Form Feed | <FF> |
| <code>\u0020</code> | Space | <SP> |
| <code>\u00A0</code> | No-break space | <NBSP> |
| <code>\uFEFF</code> | Byte Order Mark | <BOM> |
| Other category “Zs” | Any other Unicode “space separator” | <USP> |

ECMAScript implementations must recognize all of the white space characters defined in Unicode 3.0. Later editions of the Unicode Standard may define other white space characters. ECMAScript implementations may recognize white space characters from later editions of the Unicode Standard.

Syntax

WhiteSpace ::
 <TAB>
 <VT>
 <FF>
 <SP>
 <NBSP>
 <BOM>
 <USP>

7.3 Line Terminators

Like white space characters, line terminator characters are used to improve source text readability and to separate tokens (indivisible lexical units) from each other. However, unlike white space characters, line terminators have some influence over the behaviour of the syntactic grammar. In general, line terminators may occur between any two tokens, but there are a few places where they are forbidden by the syntactic grammar. Line terminators also affect the process of automatic semicolon insertion (7.9). A line terminator cannot occur within any token except a *StringLiteral*. Any line terminators within a *StringLiteral* token must be preceded by an escape sequence.

A line terminator can occur within a *MultiLineComment* (7.4) but cannot occur within a *SingleLineComment*.

Line terminators are included in the set of white space characters that are matched by the `\s` class in regular expressions.

The following characters are considered to be line terminators:

| <i>Code Unit Value</i> | <i>Name</i> | <i>Formal Name</i> |
|------------------------|---------------------|--------------------|
| <code>\u000A</code> | Line Feed | <LF> |
| <code>\u000D</code> | Carriage Return | <CR> |
| <code>\u2028</code> | Line separator | <LS> |
| <code>\u2029</code> | Paragraph separator | <PS> |

Only the characters in the above table are treated as line terminators. Other new line or line breaking characters are treated as white space but not as line terminators. The character sequence <CR><LF> is commonly used as a line terminator. It should be considered a single character for the purpose of reporting line numbers.

Syntax

LineTerminator ::

<LF>
<CR>
<LS>
<PS>

LineTerminatorSequence ::

<LF>
<CR> [lookahead ∉ <LF>]
<LS>
<PS>
<CR> <LF>

7.4 Comments

Description

Comments can be either single or multi-line. Multi-line comments cannot nest.

Because a single-line comment can contain any character except a *LineTerminator* character, and because of the general rule that a token is always as long as possible, a single-line comment always consists of all characters from the *//* marker to the end of the line. However, the *LineTerminator* at the end of the line is not considered to be part of the single-line comment; it is recognised separately by the lexical grammar and becomes part of the stream of input elements for the syntactic grammar. This point is very important, because it implies that the presence or absence of single-line comments does not affect the process of automatic semicolon insertion (7.9).

Comments behave like white space and are discarded except that, if a *MultiLineComment* contains a line terminator character, then the entire comment is considered to be a *LineTerminator* for purposes of parsing by the syntactic grammar.

Syntax

Comment ::

MultiLineComment
SingleLineComment

MultiLineComment ::

/ MultiLineCommentChars_{opt} */*

MultiLineCommentChars ::

MultiLineNotAsteriskChar MultiLineCommentChars_{opt}
** PostAsteriskCommentChars_{opt}*

PostAsteriskCommentChars ::

MultiLineNotForwardSlashOrAsteriskChar MultiLineCommentChars_{opt}
** PostAsteriskCommentChars_{opt}*

MultiLineNotAsteriskChar ::

SourceCharacter **but not** *asterisk* *****

MultiLineNotForwardSlashOrAsteriskChar ::

SourceCharacter **but not** *forward-slash* **/** **or** *asterisk* *****

SingleLineComment ::

// SingleLineCommentChars_{opt}

SingleLineCommentChars ::

SingleLineCommentChar SingleLineCommentChars_{opt}

SingleLineCommentChar ::
SourceCharacter **but not** *LineTerminator*

7.5 Tokens

Syntax

Token ::
IdentifierName
Punctuator
NumericLiteral
StringLiteral

NOTE

The DivPunctuator and RegularExpressionLiteral productions define tokens, but are not included in the Token production.

7.6 Identifier Names and Identifiers

Description

Identifier Names are tokens that are interpreted according to the grammar given in the “Identifiers” section of chapter 5 of the Unicode standard, with some small modifications. An *Identifier* is an *IdentifierName* that is not a *ReservedWord*. The Unicode identifier grammar is based on both normative and informative character categories specified by the Unicode Standard. The characters in the specified categories in version 3.0 of the Unicode standard must be treated as in those categories by all conforming ECMAScript implementations.

This standard specifies specific character additions: The dollar sign (\$) and the underscore (_) are permitted anywhere in an *IdentifierName*.

Unicode escape sequences are also permitted in an *IdentifierName*, where they contribute a single character to the *IdentifierName*, as computed by the CV of the *UnicodeEscapeSequence* (see 7.8.4). The \ preceding the *UnicodeEscapeSequence* does not contribute a character to the *IdentifierName*. A *UnicodeEscapeSequence* cannot be used to put a character into an *IdentifierName* that would otherwise be illegal. In other words, if a \ *UnicodeEscapeSequence* sequence were replaced by its *UnicodeEscapeSequence*'s CV, the result must still be a valid *IdentifierName* that has the exact same sequence of characters as the original *IdentifierName*. All interpretations of identifiers within this specification are based upon their actual characters regardless of whether or not an escape sequence was used to contribute any particular characters.

Two *IdentifierName* that are canonically equivalent according to the Unicode standard are *not* equal unless they are represented by the exact same sequence of code units (in other words, conforming ECMAScript implementations are only required to do bitwise comparison on *IdentifierName* values). The intent is that the incoming source text has been converted to normalised form C before it reaches the compiler.

ECMAScript implementations may recognize identifier characters defined in later editions of the Unicode Standard. If portability is a concern, programmers should only employ identifier characters defined in Unicode 3.0.

Syntax

Identifier ::
IdentifierName **but not** *ReservedWord*

IdentifierName ::
IdentifierStart
IdentifierName *IdentifierPart*

IdentifierStart ::
UnicodeLetter
\$
_ *UnicodeEscapeSequence*

IdentifierPart ::
IdentifierStart
UnicodeCombiningMark
UnicodeDigit
UnicodeConnectorPunctuation
<ZWJ>
<ZWJ>

UnicodeLetter
any character in the Unicode categories “Uppercase letter (Lu)”, “Lowercase letter (Ll)”, “Titlecase letter (Lt)”, “Modifier letter (Lm)”, “Other letter (Lo)”, or “Letter number (Nl)”.

UnicodeCombiningMark
any character in the Unicode categories “Non-spacing mark (Mn)” or “Combining spacing mark (Mc)”

UnicodeDigit
any character in the Unicode category “Decimal number (Nd)”

UnicodeConnectorPunctuation
any character in the Unicode category “Connector punctuation (Pc)”

UnicodeEscapeSequence
see 7.8.4.

7.6.1 Reserved Words Description

A reserved word is an *IdentifierName* that cannot be used as an *Identifier*.

Syntax
ReservedWord ::
Keyword
FutureReservedWord
NullLiteral
BooleanLiteral

7.6.1.1 Keywords

The following tokens are ECMAScript keywords and may not be used as *Identifiers* in ECMAScript programs.

Syntax
Keyword :: one of

| | | | |
|-----------------|-----------------|-------------------|---------------|
| break | do | instanceof | typeof |
| case | else | new | var |
| catch | finally | return | void |
| continue | for | switch | while |
| debugger | function | this | with |
| default | if | throw | |
| delete | in | try | |

7.6.1.2 Future Reserved Words

The following words are used as keywords in proposed extensions and are therefore reserved to allow for the possibility of future adoption of those extensions.

Syntax
FutureReservedWord :: one of

| | | | |
|--------------|---------------|----------------|--------------|
| class | enum | extends | super |
| const | export | import | |

The following tokens are also considered to be *FutureReservedWords* when they occur within strict mode code (10.1.1). The occurrence of any of these tokens within strict mode code in any context where the occurrence of a *FutureReservedWords* would produce an error must also produce an equivalent error:

| | | | | |
|-------------------|----------------|------------------|---------------|--------------|
| implements | let | private | public | yield |
| interface | package | protected | static | |

7.7 Punctuators

Syntax

Punctuator :: one of

| | | | | | |
|-----|------|-----|-----|-----|-----|
| { | } | (|) | [|] |
| . | ; | , | < | > | <= |
| >= | == | != | === | !== | |
| + | - | * | % | ++ | -- |
| << | >> | >>> | & | | ^ |
| ! | ~ | && | | ? | : |
| = | += | -= | *= | %= | <<= |
| >>= | >>>= | &= | = | ^= | |

DivPunctuator :: one of

| | |
|---|----|
| / | /= |
|---|----|

7.8 Literals

Syntax

Literal ::

- NullLiteral*
- BooleanLiteral*
- NumericLiteral*
- StringLiteral*
- RegularExpressionLiteral*

7.8.1 Null Literals

Syntax

NullLiteral ::

null

Semantics

The value of the null literal **null** is the sole value of the Null type, namely **null**.

7.8.2 Boolean Literals

Syntax

BooleanLiteral ::

true

false

Semantics

The value of the Boolean literal **true** is a value of the Boolean type, namely **true**.

The value of the Boolean literal **false** is a value of the Boolean type, namely **false**.

7.8.3 Numeric Literals

Syntax

NumericLiteral ::

DecimalLiteral
HexIntegerLiteral

DecimalLiteral ::

DecimalIntegerLiteral . *DecimalDigits*_{opt} *ExponentPart*_{opt}
. *DecimalDigits* *ExponentPart*_{opt}
DecimalIntegerLiteral *ExponentPart*_{opt}

DecimalIntegerLiteral ::

0
NonZeroDigit *DecimalDigits*_{opt}

DecimalDigits ::

DecimalDigit
DecimalDigits *DecimalDigit*

DecimalDigit :: one of

0 1 2 3 4 5 6 7 8 9

NonZeroDigit :: one of

1 2 3 4 5 6 7 8 9

ExponentPart ::

ExponentIndicator *SignedInteger*

ExponentIndicator :: one of

e E

SignedInteger ::

DecimalDigits
+ *DecimalDigits*
- *DecimalDigits*

HexIntegerLiteral ::

0x *HexDigit*
0X *HexDigit*
HexIntegerLiteral *HexDigit*

HexDigit :: one of

0 1 2 3 4 5 6 7 8 9 a b c d e f A B C D E F

The source character immediately following a *NumericLiteral* must not be an *IdentifierStart* or *DecimalDigit*.

NOTE

For example:

3in

is an error and not the two input elements **3** and **in**.

Semantics

A numeric literal stands for a value of the Number type. This value is determined in two steps: first, a mathematical value (MV) is derived from the literal; second, this mathematical value is rounded as described below.

- The MV of *NumericLiteral* :: *DecimalLiteral* is the MV of *DecimalLiteral*.
- The MV of *NumericLiteral* :: *HexIntegerLiteral* is the MV of *HexIntegerLiteral*.
- The MV of *DecimalLiteral* :: *DecimalIntegerLiteral* . is the MV of *DecimalIntegerLiteral*.
- The MV of *DecimalLiteral* :: *DecimalIntegerLiteral* . *DecimalDigits* is the MV of *DecimalIntegerLiteral* plus (the MV of *DecimalDigits* times 10^{-n}), where *n* is the number of characters in *DecimalDigits*.
- The MV of *DecimalLiteral* :: *DecimalIntegerLiteral* . *ExponentPart* is the MV of *DecimalIntegerLiteral* times 10^e , where *e* is the MV of *ExponentPart*.
- The MV of *DecimalLiteral* :: *DecimalIntegerLiteral* . *DecimalDigits* *ExponentPart* is (the MV of *DecimalIntegerLiteral* plus (the MV of *DecimalDigits* times 10^{-n})) times 10^e , where *n* is the number of characters in *DecimalDigits* and *e* is the MV of *ExponentPart*.
- The MV of *DecimalLiteral* :: . *DecimalDigits* is the MV of *DecimalDigits* times 10^{-n} , where *n* is the number of characters in *DecimalDigits*.
- The MV of *DecimalLiteral* :: . *DecimalDigits* *ExponentPart* is the MV of *DecimalDigits* times 10^{e-n} , where *n* is the number of characters in *DecimalDigits* and *e* is the MV of *ExponentPart*.
- The MV of *DecimalLiteral* :: *DecimalIntegerLiteral* is the MV of *DecimalIntegerLiteral*.
- The MV of *DecimalLiteral* :: *DecimalIntegerLiteral* *ExponentPart* is the MV of *DecimalIntegerLiteral* times 10^e , where *e* is the MV of *ExponentPart*.
- The MV of *DecimalIntegerLiteral* :: 0 is 0.
- The MV of *DecimalIntegerLiteral* :: *NonZeroDigit* *DecimalDigits* is (the MV of *NonZeroDigit* times 10^n) plus the MV of *DecimalDigits*, where *n* is the number of characters in *DecimalDigits*.
- The MV of *DecimalDigits* :: *DecimalDigit* is the MV of *DecimalDigit*.
- The MV of *DecimalDigits* :: *DecimalDigits* *DecimalDigit* is (the MV of *DecimalDigits* times 10) plus the MV of *DecimalDigit*.
- The MV of *ExponentPart* :: *ExponentIndicator* *SignedInteger* is the MV of *SignedInteger*.
- The MV of *SignedInteger* :: *DecimalDigits* is the MV of *DecimalDigits*.
- The MV of *SignedInteger* :: + *DecimalDigits* is the MV of *DecimalDigits*.
- The MV of *SignedInteger* :: - *DecimalDigits* is the negative of the MV of *DecimalDigits*.
- The MV of *DecimalDigit* :: 0 or of *HexDigit* :: 0 is 0.
- The MV of *DecimalDigit* :: 1 or of *NonZeroDigit* :: 1 or of *HexDigit* :: 1 is 1.
- The MV of *DecimalDigit* :: 2 or of *NonZeroDigit* :: 2 or of *HexDigit* :: 2 is 2.
- The MV of *DecimalDigit* :: 3 or of *NonZeroDigit* :: 3 or of *HexDigit* :: 3 is 3.
- The MV of *DecimalDigit* :: 4 or of *NonZeroDigit* :: 4 or of *HexDigit* :: 4 is 4.
- The MV of *DecimalDigit* :: 5 or of *NonZeroDigit* :: 5 or of *HexDigit* :: 5 is 5.
- The MV of *DecimalDigit* :: 6 or of *NonZeroDigit* :: 6 or of *HexDigit* :: 6 is 6.
- The MV of *DecimalDigit* :: 7 or of *NonZeroDigit* :: 7 or of *HexDigit* :: 7 is 7.
- The MV of *DecimalDigit* :: 8 or of *NonZeroDigit* :: 8 or of *HexDigit* :: 8 is 8.
- The MV of *DecimalDigit* :: 9 or of *NonZeroDigit* :: 9 or of *HexDigit* :: 9 is 9.
- The MV of *HexDigit* :: a or of *HexDigit* :: A is 10.
- The MV of *HexDigit* :: b or of *HexDigit* :: B is 11.
- The MV of *HexDigit* :: c or of *HexDigit* :: C is 12.
- The MV of *HexDigit* :: d or of *HexDigit* :: D is 13.
- The MV of *HexDigit* :: e or of *HexDigit* :: E is 14.
- The MV of *HexDigit* :: f or of *HexDigit* :: F is 15.
- The MV of *HexIntegerLiteral* :: 0x *HexDigit* is the MV of *HexDigit*.
- The MV of *HexIntegerLiteral* :: 0X *HexDigit* is the MV of *HexDigit*.
- The MV of *HexIntegerLiteral* :: *HexIntegerLiteral* *HexDigit* is (the MV of *HexIntegerLiteral* times 16) plus the MV of *HexDigit*.

Once the exact MV for a numeric literal has been determined, it is then rounded to a value of the Number type. If the MV is 0, then the rounded value is +0; otherwise, the rounded value must be *the* number value for the MV (in the sense defined in 8.5), unless the literal is a *DecimalLiteral* and the literal has more than 20 significant digits, in which case the number value may be either the number value for the MV of a literal produced by replacing each significant digit after the 20th with a 0 digit or the number

value for the MV of a literal produced by replacing each significant digit after the 20th with a 0 digit and then incrementing the literal at the 20th significant digit position. A digit is *significant* if it is not part of an *ExponentPart* and

- it is not 0; or
- there is a nonzero digit to its left and there is a nonzero digit, not in the *ExponentPart*, to its right.

A conforming implementation, when processing strict mode code (10.1.1), must not extend the syntax of *NumericLiteral* to include *OctalIntegerLiteral* as described in B.1.1.

7.8.4 String Literals

A string literal is zero or more characters enclosed in single or double quotes. Each character may be represented by an escape sequence. All characters may appear literally in a string literal except for the closing quote character, backslash, carriage return, line separator, paragraph separator, and line feed. Any character may appear in the form of an escape sequence.

Syntax

StringLiteral ::

" *DoubleStringCharacters*_{opt} "
' *SingleStringCharacters*_{opt} '

DoubleStringCharacters ::

DoubleStringCharacter *DoubleStringCharacters*_{opt}

SingleStringCharacters ::

SingleStringCharacter *SingleStringCharacters*_{opt}

DoubleStringCharacter ::

SourceCharacter **but not** double-quote " **or** backslash \ **or** *LineTerminator*
\ *EscapeSequence*
LineContinuation

SingleStringCharacter ::

SourceCharacter **but not** single-quote ' **or** backslash \ **or** *LineTerminator*
\ *EscapeSequence*
LineContinuation

LineContinuation ::

\ *LineTerminatorSequence*

EscapeSequence ::

CharacterEscapeSequence
0 [lookahead ∉ *DecimalDigit*]
HexEscapeSequence
UnicodeEscapeSequence

CharacterEscapeSequence ::

SingleEscapeCharacter
NonEscapeCharacter

SingleEscapeCharacter :: **one of**

' " \ b f n r t v

NonEscapeCharacter ::
SourceCharacter **but not** *EscapeCharacter* **or** *LineTerminator*

EscapeCharacter ::
SingleEscapeCharacter
DecimalDigit
x
u

HexEscapeSequence ::
x *HexDigit* *HexDigit*

UnicodeEscapeSequence ::
u *HexDigit* *HexDigit* *HexDigit* *HexDigit*

The definitions of the nonterminal *HexDigit* is given in section 7.6. *SourceCharacter* is described in sections 2 and 6.

A string literal stands for a value of the `String` type. The string value (SV) of the literal is described in terms of character values (CV) contributed by the various parts of the string literal. As part of this process, some characters within the string literal are interpreted as having a mathematical value (MV), as described below or in section 7.8.3.

- The SV of *StringLiteral* :: "" is the empty character sequence.
- The SV of *StringLiteral* :: ' ' is the empty character sequence.
- The SV of *StringLiteral* :: " *DoubleStringCharacters* " is the SV of *DoubleStringCharacters*.
- The SV of *StringLiteral* :: ' *SingleStringCharacters* ' is the SV of *SingleStringCharacters*.
- The SV of *DoubleStringCharacters* :: *DoubleStringCharacter* is a sequence of one character, the CV of *DoubleStringCharacter*.
- The SV of *DoubleStringCharacters* :: *DoubleStringCharacter* *DoubleStringCharacters* is a sequence of the CV of *DoubleStringCharacter* followed by all the characters in the SV of *DoubleStringCharacters* in order.
- The SV of *SingleStringCharacters* :: *SingleStringCharacter* is a sequence of one character, the CV of *SingleStringCharacter*.
- The SV of *SingleStringCharacters* :: *SingleStringCharacter* *SingleStringCharacters* is a sequence of the CV of *SingleStringCharacter* followed by all the characters in the SV of *SingleStringCharacters* in order.
- The SV of *LineContinuation* :: \ *LineTerminatorSequence* is the empty character sequence.
- The CV of *DoubleStringCharacter* :: *SourceCharacter* **but not** *double-quote* " **or** *backslash* \ **or** *LineTerminator* is the *SourceCharacter* character itself.
- The CV of *DoubleStringCharacter* :: \ *EscapeSequence* is the CV of the *EscapeSequence*.
- The CV of *SingleStringCharacter* :: *SourceCharacter* **but not** *single-quote* ' **or** *backslash* \ **or** *LineTerminator* is the *SourceCharacter* character itself.
- The CV of *SingleStringCharacter* :: \ *EscapeSequence* is the CV of the *EscapeSequence*.
- The CV of *EscapeSequence* :: *CharacterEscapeSequence* is the CV of the *CharacterEscapeSequence*.
- The CV of *EscapeSequence* :: **0** [lookahead \notin *DecimalDigit*] is a <NUL> character (Unicode value 0000).
- The CV of *EscapeSequence* :: *HexEscapeSequence* is the CV of the *HexEscapeSequence*.
- The CV of *EscapeSequence* :: *UnicodeEscapeSequence* is the CV of the *UnicodeEscapeSequence*.
- The CV of *CharacterEscapeSequence* :: *SingleEscapeCharacter* is the character whose code unit value is determined by the *SingleEscapeCharacter* according to the following table:

| <i>Escape Sequence</i> | <i>Code Unit Value</i> | <i>Name</i> | <i>Symbol</i> |
|------------------------|------------------------|----------------------|---------------|
| <code>\b</code> | <code>\u0008</code> | backspace | <BS> |
| <code>\t</code> | <code>\u0009</code> | horizontal tab | <HT> |
| <code>\n</code> | <code>\u000A</code> | line feed (new line) | <LF> |
| <code>\v</code> | <code>\u000B</code> | vertical tab | <VT> |
| <code>\f</code> | <code>\u000C</code> | form feed | <FF> |
| <code>\r</code> | <code>\u000D</code> | carriage return | <CR> |
| <code>\"</code> | <code>\u0022</code> | double quote | " |
| <code>\'</code> | <code>\u0027</code> | single quote | ' |
| <code>\\</code> | <code>\u005C</code> | backslash | \ |

- The CV of *CharacterEscapeSequence* :: *NonEscapeCharacter* is the CV of the *NonEscapeCharacter*.
- The CV of *NonEscapeCharacter* :: *SourceCharacter* **but not** *EscapeCharacter* **or** *LineTerminator* is the *SourceCharacter* character itself.
- The CV of *HexEscapeSequence* :: **x** *HexDigit HexDigit* is the character whose code unit value is (16 times the MV of the first *HexDigit*) plus the MV of the second *HexDigit*.
- The CV of *UnicodeEscapeSequence* :: **u** *HexDigit HexDigit HexDigit HexDigit* is the character whose code unit value is (4096 times the MV of the first *HexDigit*) plus (256 times the MV of the second *HexDigit*) plus (16 times the MV of the third *HexDigit*) plus the MV of the fourth *HexDigit*.

A conforming implementation, when processing strict mode code (10.1.1), may not extend the syntax of *EscapeSequence* to include *OctalEscapeSequence* as described in B.1.1.

NOTE

A line terminator character cannot appear in a string literal, except as part of a LineContinuation to produce the empty character sequence. The correct way to cause a line terminator character to be part of the string value of a string literal is to use an escape sequence such as \n or \u000A.

7.8.5 Regular Expression Literals

A regular expression literal is an input element that is converted to a `RegExp` object (section 15.10) each time the literal is evaluated. Two regular expression literals in a program evaluate to regular expression objects that never compare as `===` to each other even if the two literals' contents are identical. A `RegExp` object may also be created at runtime by `new RegExp` (section 15.10.4) or calling the `RegExp` constructor as a function (section 15.10.3).

The productions below describe the syntax for a regular expression literal and are used by the input element scanner to find the end of the regular expression literal. The strings of characters comprising the *RegularExpressionBody* and the *RegularExpressionFlags* are passed uninterpreted to the regular expression constructor, which interprets them according to its own, more stringent grammar. An implementation may extend the regular expression constructor's grammar, but it must not extend the *RegularExpressionBody* and *RegularExpressionFlags* productions or the productions used by these productions.

Syntax

RegularExpressionLiteral ::
/ RegularExpressionBody / RegularExpressionFlags

RegularExpressionBody ::
RegularExpressionFirstChar RegularExpressionChars

RegularExpressionChars ::
_[empty]
RegularExpressionChars RegularExpressionChar

RegularExpressionFirstChar ::
 RegularExpressionNonTerminator **but not** * or \ or / or [
 RegularExpressionBackslashSequence
 RegularExpressionClass

RegularExpressionChar ::
 RegularExpressionNonTerminator **but not** \ or / or [
 RegularExpressionBackslashSequence
 RegularExpressionClass

RegularExpressionBackslashSequence ::
 RegularExpressionNonTerminator

RegularExpressionNonTerminator ::
 SourceCharacter **but not** *LineTerminator*

RegularExpressionClass ::
 [*RegularExpressionClassChars*]

RegularExpressionClassChars ::
 [empty]
 RegularExpressionClassChars *RegularExpressionClassChar*

RegularExpressionClassChar ::
 RegularExpressionNonTerminator **but not**] or \
 RegularExpressionBackslashSequence

RegularExpressionFlags ::
 [empty]
 RegularExpressionFlags *IdentifierPart*

NOTE

Regular expression literals may not be empty; instead of representing an empty regular expression literal, the characters // start a single-line comment. To specify an empty regular expression, use /(?:)/.

Semantics

A regular expression literal evaluates to a value of the Object type that is an instance of the standard built-in constructor `RegExp`. This value is determined in two steps: first, the characters comprising the regular expression's *RegularExpressionBody* and *RegularExpressionFlags* production expansions are collected uninterpreted into two strings `Pattern` and `Flags`, respectively. Then each time the literal is evaluated, a new object is created as if by the expression `new RegExp(Pattern, Flags)` where `RegExp` is the standard built-in constructor with that name. The newly constructed object becomes the value of the *RegularExpressionLiteral*. If the call to `new RegExp` would generate an error specified in 15.10.4.1, the error must be treated as an early error (Section 16).

7.9 Automatic Semicolon Insertion

Certain ECMAScript statements (empty statement, variable statement, expression statement, **do-while** statement, **continue** statement, **break** statement, **return** statement, and **throw** statement) must be terminated with semicolons. Such semicolons may always appear explicitly in the source text. For convenience, however, such semicolons may be omitted from the source text in certain situations. These situations are described by saying that semicolons are automatically inserted into the source code token stream in those situations.

7.9.1 Rules of Automatic Semicolon Insertion

- When, as the program is parsed from left to right, a token (called the *offending token*) is encountered that is not allowed by any production of the grammar, then a semicolon is automatically inserted before the offending token if one or more of the following conditions is true:

1. The offending token is separated from the previous token by at least one *LineTerminator*.
 2. The offending token is `}`.
- When, as the program is parsed from left to right, the end of the input stream of tokens is encountered and the parser is unable to parse the input token stream as a single complete ECMAScript *Program*, then a semicolon is automatically inserted at the end of the input stream.
 - When, as the program is parsed from left to right, a token is encountered that is allowed by some production of the grammar, but the production is a *restricted production* and the token would be the first token for a terminal or nonterminal immediately following the annotation “[no *LineTerminator* here]” within the restricted production (and therefore such a token is called a restricted token), and the restricted token is separated from the previous token by at least one *LineTerminator*, then a semicolon is automatically inserted before the restricted token.

However, there is an additional overriding condition on the preceding rules: a semicolon is never inserted automatically if the semicolon would then be parsed as an empty statement or if that semicolon would become one of the two semicolons in the header of a **for** statement (section 12.6.3).

NOTE

These are the only restricted productions in the grammar:

PostfixExpression :

LeftHandSideExpression [no *LineTerminator* here] **++**

LeftHandSideExpression [no *LineTerminator* here] **--**

ContinueStatement :

continue [no *LineTerminator* here] *Identifier*_{opt} ;

BreakStatement :

break [no *LineTerminator* here] *Identifier*_{opt} ;

ReturnStatement :

return [no *LineTerminator* here] *Expression*_{opt} ;

ThrowStatement :

throw [no *LineTerminator* here] *Expression* ;

The practical effect of these restricted productions is as follows:

- When a **++** or **--** token is encountered where the parser would treat it as a postfix operator, and at least one *LineTerminator* occurred between the preceding token and the **++** or **--** token, then a semicolon is automatically inserted before the **++** or **--** token.
- When a **continue**, **break**, **return**, or **throw** token is encountered and a *LineTerminator* is encountered before the next token, a semicolon is automatically inserted after the **continue**, **break**, **return**, or **throw** token.

The resulting practical advice to ECMAScript programmers is:

- A postfix **++** or **--** operator should appear on the same line as its operand.
- An *Expression* in a **return** or **throw** statement should start on the same line as the **return** or **throw** token.
- A label in a **break** or **continue** statement should be on the same line as the **break** or **continue** token.

7.9.2 Examples of Automatic Semicolon Insertion

The source

```
{ 1 2 } 3
```

is not a valid sentence in the ECMAScript grammar, even with the automatic semicolon insertion rules. In contrast, the source

```
{ 1
 2 } 3
```

is also not a valid ECMAScript sentence, but is transformed by automatic semicolon insertion into the following:

```
{ 1
  ;2 ;} 3;
```

which is a valid ECMAScript sentence.

The source

```
for (a; b
)
```

is not a valid ECMAScript sentence and is not altered by automatic semicolon insertion because the semicolon is needed for the header of a **for** statement. Automatic semicolon insertion never inserts one of the two semicolons in the header of a **for** statement.

The source

```
return
a + b
```

is transformed by automatic semicolon insertion into the following:

```
return;
a + b;
```

NOTE

*The expression **a + b** is not treated as a value to be returned by the **return** statement, because a 'LineTerminator' separates it from the token **return**.*

The source

```
a = b
++c
```

is transformed by automatic semicolon insertion into the following:

```
a = b;
++c;
```

NOTE

*The token **++** is not treated as a postfix operator applying to the variable **b**, because a 'LineTerminator' occurs between **b** and **++**.*

The source

```
if (a > b)
else c = d
```

is not a valid ECMAScript sentence and is not altered by automatic semicolon insertion before the **else** token, even though no production of the grammar applies at that point, because an automatically inserted semicolon would then be parsed as an empty statement.

The source

```
a = b + c
(d + e).print()
```

is *not* transformed by automatic semicolon insertion, because the parenthesised expression that begins the second line can be interpreted as an argument list for a function call:

```
a = b + c(d + e).print()
```

In the circumstance that an assignment statement must begin with a left parenthesis, it is a good idea for the programmer to provide an explicit semicolon at the end of the preceding statement rather than to rely on automatic semicolon insertion.

DRAFT

8 Types

Algorithms within this specification manipulate values each of which has an associated type. The possible value types are exactly those defined in this section. Types are further subclassified into ECMAScript language types and specification types.

An ECMAScript language type corresponds to values that are directly manipulated by an ECMAScript programmer using the ECMAScript language. The ECMAScript language types are Undefined, Null, Boolean, String, Number, and Object.

A specification type corresponds to meta-values that are used within algorithms to describe the semantics of ECMAScript language constructs and ECMAScript language types. The specification types are Reference, List, Completion, Property Descriptor, Property Identifier, Lexical Environment, and Environment Record. Specification type values are specification artefacts that do not necessarily correspond to any specific entity within an ECMAScript implementation. Specification type values may be used to describe intermediate results of ECMAScript expression evaluation but such values cannot be stored as properties of objects or values of ECMAScript language variables.

Within this specification, the notation “Type(*x*)” is used as shorthand for “the type of *x*” where “type” refers to the ECMAScript language and specification types defined in this section.

8.1 The Undefined Type

The Undefined type has exactly one value, called **undefined**. Any variable that has not been assigned a value has the value **undefined**.

8.2 The Null Type

The Null type has exactly one value, called **null**.

8.3 The Boolean Type

The Boolean type represents a logical entity having two values, called **true** and **false**.

8.4 The String Type

The String type is the set of all finite ordered sequences of zero or more 16-bit unsigned integer values (“elements”). The String type is generally used to represent textual data in a running ECMAScript program, in which case each element in the string is treated as a code unit value (see section 6). Each element is regarded as occupying a position within the sequence. These positions are indexed with nonnegative integers. The first element (if any) is at position 0, the next element (if any) at position 1, and so on. The length of a string is the number of elements (i.e., 16-bit values) within it. The empty string has length zero and therefore contains no elements.

When a string contains actual textual data, each element is considered to be a single UTF-16 code unit. Whether or not this is the actual storage format of a String, the characters within a String are numbered by their initial code unit element position as though they were represented using UTF-16. All operations on Strings (except as otherwise stated) treat them as sequences of undifferentiated 16-bit unsigned integers; they do not ensure the resulting string is in normalised form, nor do they ensure language-sensitive results.

NOTE

The rationale behind these decisions was to keep the implementation of Strings as simple and high-performing as possible. The intent is that textual data coming into the execution environment from outside (e.g., user input, text read from a file or received over the network, etc.) be converted to Unicode Normalised Form C before the running program sees it. Usually this would occur at the same time incoming text is converted from its original character encoding to Unicode (and would impose no additional overhead). Since it is recommended that ECMAScript source code be in Normalised Form C, string literals are guaranteed to be normalised (if source text is guaranteed to be normalised), as long as they do not contain any Unicode escape sequences.

8.5 The Number Type

The Number type has exactly 18437736874454810627 (that is, $2^{64}-2^{53}+3$) values, representing the double-precision 64-bit format IEEE 754 values as specified in the IEEE Standard for Binary Floating-Point Arithmetic, except that the 9007199254740990 (that is, $2^{53}-2$) distinct “Not-a-Number” values of the IEEE

Standard are represented in ECMAScript as a single special **NaN** value. (Note that the **NaN** value is produced by the program expression **NaN**.) In some implementations, external code might be able to detect a difference between various Not-a-Number values, but such behaviour is implementation-dependent; to ECMAScript code, all NaN values are indistinguishable from each other.

There are two other special values, called **positive Infinity** and **negative Infinity**. For brevity, these values are also referred to for expository purposes by the symbols $+\infty$ and $-\infty$, respectively. (Note that these two infinite number values are produced by the program expressions **+Infinity** (or simply **Infinity**) and **-Infinity**.)

The other 18437736874454810624 (that is, $2^{64}-2^{53}$) values are called the finite numbers. Half of these are positive numbers and half are negative numbers; for every finite positive number there is a corresponding negative number having the same magnitude.

Note that there is both a **positive zero** and a **negative zero**. For brevity, these values are also referred to for expository purposes by the symbols **+0** and **-0**, respectively. (Note that these two zero number values are produced by the program expressions **+0** (or simply **0**) and **-0**.)

The 18437736874454810622 (that is, $2^{64}-2^{53}-2$) finite nonzero values are of two kinds:

18428729675200069632 (that is, $2^{64}-2^{54}$) of them are normalised, having the form

$$s \times m \times 2^e$$

where s is $+1$ or -1 , m is a positive integer less than 2^{53} but not less than 2^{52} , and e is an integer ranging from -1074 to 971 , inclusive.

The remaining 9007199254740990 (that is, $2^{53}-2$) values are denormalised, having the form

$$s \times m \times 2^e$$

where s is $+1$ or -1 , m is a positive integer less than 2^{52} , and e is -1074 .

Note that all the positive and negative integers whose magnitude is no greater than 2^{53} are representable in the Number type (indeed, the integer 0 has two representations, **+0** and **-0**).

A finite number has an *odd significand* if it is nonzero and the integer m used to express it (in one of the two forms shown above) is odd. Otherwise, it has an *even significand*.

In this specification, the phrase “the number value for x ” where x represents an exact nonzero real mathematical quantity (which might even be an irrational number such as π) means a number value chosen in the following manner. Consider the set of all finite values of the Number type, with **-0** removed and with two additional values added to it that are not representable in the Number type, namely 2^{1024} (which is $+1 \times 2^{53} \times 2^{971}$) and -2^{1024} (which is $-1 \times 2^{53} \times 2^{971}$). Choose the member of this set that is closest in value to x . If two values of the set are equally close, then the one with an even significand is chosen; for this purpose, the two extra values 2^{1024} and -2^{1024} are considered to have even significands. Finally, if 2^{1024} was chosen, replace it with $+\infty$; if -2^{1024} was chosen, replace it with $-\infty$; if **+0** was chosen, replace it with **-0** if and only if x is less than zero; any other chosen value is used unchanged. The result is the number value for x . (This procedure corresponds exactly to the behaviour of the IEEE 754 “round to nearest” mode.)

Some ECMAScript operators deal only with integers in the range -2^{31} through $2^{31}-1$, inclusive, or in the range 0 through $2^{32}-1$, inclusive. These operators accept any value of the Number type but first convert each such value to one of 2^{32} integer values. See the descriptions of the ToInt32 and ToUint32 operators in sections 9.5 and 9.6, respectively.

8.6 The Object Type

An Object is a collection of properties. Each property is either a named data property, a named accessor property, or an internal property.

- A *named data property* associates a name with an ECMAScript language value and a set of Boolean attributes.

- A *named accessor property* associates a name with one or two accessor functions, and a set of Boolean attributes. The accessor functions are used to store or retrieve an ECMAScript language value that is associated with the property.
- An *internal property* has no name and is not directly accessible via ECMAScript language operators. Internal properties exist purely for specification purposes.

There are two types of access for named (non-internal) properties: *get* and *put*, corresponding to retrieval and assignment, respectively.

8.6.1 Property Attributes

Attributes are used in this specification to define and explain the state of named properties. A named data property associates a name with the following attributes:

Table 1 Attributes of a Named Data Property

| <i>Attribute Name</i> | <i>Value Domain</i> | <i>Description</i> |
|-----------------------|------------------------------|---|
| [[Value]] | Any ECMAScript language type | The value retrieved by reading the property. |
| [[Writable]] | Boolean | If false , attempts by ECMAScript code to change the property's [[Value]] attribute using [[Put]] will not succeed. |
| [[Enumerable]] | Boolean | If true , the property will be enumerated by a for-in enumeration (section 12.6.4). Otherwise, the property is said to be non-enumerable. |
| [[Configurable]] | Boolean | If false , attempts to delete the property, change the property to be an accessor property, or change its attributes (other than [[Value]]) will fail. |

A named accessor property associates a name with the following attributes:

Table 2 Attributes of a Named Accessor Property

| <i>Attribute Name</i> | <i>Value Domain</i> | <i>Description</i> |
|-----------------------|----------------------------|--|
| [[Get]] | Object <i>or</i> Undefined | If the value is an Object it must be a function Object. The function's [[Call]] internal method (8.6.2) is called with an empty arguments list to return the property value each time a get access of the property is performed. |
| [[Set]] | Object <i>or</i> Undefined | If the value is an Object it must be a function Object. The function's [[Call]] internal method (8.6.2) is called with an empty arguments list containing the assigned value as its sole argument each time a set access of the property is performed. The effect of a property's [[Set]] internal method may, but is not required to, have an effect on the value returned by subsequent calls to the property's [[Get]] internal method. |
| [[Enumerable]] | Boolean | If true , the property is to be enumerated by a for-in enumeration (section 12.6.4). Otherwise, the property is said to be non-enumerable. |
| [[Configurable]] | Boolean | If false , attempts to delete the property, change the property to be a data property, or change its attributes will fail. |

If the value of an attribute is not explicitly specified by this specification for a named property, the default value defined in the following table is used:

Table 3 Default Attribute Values

| Attribute Name | Default Value |
|------------------|------------------|
| [[Value]] | undefined |
| [[Get]] | undefined |
| [[Set]] | undefined |
| [[Writable]] | false |
| [[Enumerable]] | false |
| [[Configurable]] | false |

8.6.2 Object Internal Properties and Methods

This specification uses various internal properties to define the semantics of object values. These internal properties are not part of the ECMAScript language. They are defined by this specification purely for expository purposes. An implementation of ECMAScript must behave as if it produced and operated upon internal properties in the manner described here. The names of internal properties are enclosed in double square brackets [[]]. When an algorithm uses an internal property of an object and the object does not implement the indicated internal property, a **TypeError** exception is thrown.

The following table summarises the internal properties used by this specification that are applicable to all ECMAScript objects. The description indicates their behaviour for native ECMAScript objects, unless stated otherwise in this document for particular types of ECMAScript objects. Host objects may support these internal properties with any implementation-dependent behaviour as long as it is consistent with the specific host object restrictions stated in this document.

The “Value Type Domain” columns of the following tables define the types of values associated with internal properties. The type names refer to the types defined in section 8 augmented by the following additional names. “*any*” means the value may be any ECMAScript language type. “*primitive*” means Undefined, Null, Boolean, String, or Number. “*SpecOp*” means the internal property is an internal method, an implementation provided procedure defined by an abstract operation specification. “SpecOp” is followed by a list of descriptive parameter names. If a parameter name is the same as a type name then the name describes the type of the parameter. If a “SpecOp” returns a value, its parameter list is followed by the symbol “→” and the type of the returned value.

Table 4 Internal Properties Common to All Objects

| <i>Internal Property</i> | <i>Value Type Domain</i> | <i>Description</i> |
|--------------------------|--|--|
| [[Prototype]] | Object or Null | The prototype of this object. |
| [[Class]] | String | A string value indicating a specification defined classification of objects. |
| [[Extensible]] | Boolean | If true , own properties may be added to the object. |
| [[Get]] | SpecOp(<i>propertyName</i>) → any | Returns the value of the named property. |
| [[GetOwnProperty]] | SpecOp(<i>propertyName</i>) → Undefined or Property Descriptor | Returns the Property Descriptor of the named own property of this object, or undefined if absent. |
| [[GetProperty]] | SpecOp(<i>propertyName</i>) → Undefined or Property Descriptor | Returns the fully populated Property Descriptor of the named property of this object, or undefined if absent. |
| [[Put]] | SpecOp(<i>propertyName</i> , any, Boolean) | Sets the specified named property to the value of the second parameter. The flag controls failure handling. |
| [[CanPut]] | SpecOp(<i>propertyName</i>) → Boolean | Returns a Boolean value indicating whether a [[Put]] operation with <i>propertyName</i> can be performed. |
| [[HasProperty]] | SpecOp(<i>propertyName</i>) → Boolean | Returns a Boolean value indicating whether the object already has a property with the given name. |
| [[Delete]] | SpecOp(<i>propertyName</i> , Boolean) → Boolean | Removes the specified named own property from the object. The flag controls failure handling. |
| [[DefaultValue]] | SpecOp(<i>Hint</i>) → primitive | <i>Hint</i> is a string. Returns a default value for the object. |
| [[DefineOwnProperty]] | SpecOp(<i>propertyName</i> , PropertyDescriptor, Boolean) → Boolean | Creates or alters the named own property to have the state described by a Property Descriptor. The flag controls failure handling. |

Every object (including host objects) must implement all of the internal properties listed in Table 4. However, the [[DefaultValue]] internal method may, for some objects, simply throw a **TypeError** exception.

All objects have an internal property called [[Prototype]]. The value of this property is either **null** or an object and is used for implementing inheritance. Whether or not a native object can have a host object as its [[Prototype]] depends on the implementation. Every [[Prototype]] chain must have finite length (that is, starting from any object, recursively accessing the [[Prototype]] internal property must eventually lead to a **null** value). Named data properties of the [[Prototype]] object are inherited (are visible as properties of the child object) for the purposes of get access, but not for put access. Named accessor properties are inherited for both get access and put access.

Every ECMAScript object has a Boolean-valued [[Extensible]] internal property that controls whether or not named properties may be added to the object. If the value of the [[Extensible]] internal property is **false** then additional named properties may not be added to the object. In addition, if [[Extensible]] is **false** the value of the [[Class]] and [[Prototype]] internal properties of the object may not be modified. Once the value of an [[Extensible]] internal property has been set to **false** it may not be subsequently changed to **true**.

NOTE

*This specification defines no ECMAScript language operators or built-in functions that permit a program to modify an object's [[Class]] or [[Prototype]] internal properties or to change the value of [[Extensible]] from **false** to **true**. Implementation specific extensions that modify [[Class]], [[Prototype]] or [[Extensible]] must not violate the invariants defined in the preceding paragraph.*

The value of the [[Class]] internal property is defined by this specification for every kind of built-in object. The value of the [[Class]] internal property of a host object may be any String value except one of "Arguments", "Array", "Boolean", "Date", "Error", "Function", "JSON", "Math", "Number", "Object", "RegExp", and "String". The value of a [[Class]] internal property is used internally to distinguish different kinds of objects. Note that this specification does not provide any

means for a program to access that value except through `Object.prototype.toString` (see 15.2.4.2).

For most native objects the common internal methods behave as described in 8.12, except that Array objects have a slightly different implementation of the `[[DefineOwnProperty]]` internal method (see 15.4.5.1) and String objects have a slightly different implementation of the `[[GetOwnProperty]]` internal method (see 15.5.5.2). Arguments objects (10.6) have different implementations of `[[Get]]`, `[[GetOwnProperty]]`, `[[DefineOwnProperty]]`, and `[[Delete]]`.

Host objects may implement these internal methods in any manner unless specified otherwise; for example, one possibility is that `[[Get]]` and `[[Put]]` for a particular host object indeed fetch and store property values but `[[HasProperty]]` always generates **false**.

The `[[GetOwnProperty]]` internal method of a host object must conform to the following invariants for each property of the host object:

- If a property is described as a data property and it may return different values over time, then either or both of the `[[Writable]]` and `[[Configurable]]` attributes must be **true** even if no mechanism to change the value is exposed via the other internal methods.
- If a property is described as a data property and its `[[Writable]]` and `[[Configurable]]` are both, then the SameValue (9.12) must be returned for the `[[Value]]` attribute of the property on all calls to `[[GetOwnProperty]]`.
- If the attributes other than `[[Writable]]` may change over time or if the property might disappear, then the `[[Configurable]]` attribute must be **true**.
- If the `[[Writable]]` attribute may change from **false** to **true**, then the `[[Configurable]]` attribute must be **true**.
- If the value of the host object's `[[Extensible]]` internal property is has been observed by ECMAScript code to be **false**, then if a call to `[[GetOwnProperty]]` describes a property as non-existent all subsequent calls must also describe that property as non-existent.

The `[[DefineOwnProperty]]` internal method of a host object must not permit the addition of a new property to a host object if the `[[Extensible]]` internal property of that host object has been observed by ECMAScript code to be **false**.

If the `[[Extensible]]` internal property of that host object has been observed by ECMAScript code to be **false** then it must not subsequently become **true**.

Table 5 Internal Properties Only Defined for Some Objects

| <i>Internal Property</i> | <i>Value Type Domain</i> | <i>Description</i> |
|--------------------------|---|--|
| [[PrimitiveValue]] | <i>primitive</i> | Internal state information associated with this object. Of the standard built-in ECMAScript objects, only Boolean, Date, Number, and String objects implement [[PrimitiveValue]]. |
| [[Construct]] | SpecOp(a List of <i>any</i>) → Object | Creates an object. Invoked via the new operator. The arguments to the SpecOp are the arguments passed to the new operator. Objects that implement this internal method are called <i>constructors</i> . |
| [[Call]] | SpecOp(<i>any</i> , a List of <i>any</i>) → <i>any</i> or Reference | Executes code associated with the object. Invoked via a function call expression. The arguments to the SpecOp are a this object and a list containing the arguments passed to the function call expression. Objects that implement this internal method are <i>callable</i> . Only callable objects that are host objects may return Reference values. |
| [[HasInstance]] | SpecOp(<i>any</i>) → Boolean | Returns a Boolean value indicating whether the argument is likely an Object that was constructed by this object. Of the standard built-in ECMAScript objects, only Function objects implement [[HasInstance]]. |
| [[Scope]] | Lexical Environment | A lexical environment that defines the environment in which a Function object is executed. Of the standard built-in ECMAScript objects, only Function objects implement [[Scope]]. |
| [[FormalParameters]] | List of Strings | A possibly empty List containing the identifier strings of a Function's <i>FormalParameterList</i> . Of the standard built-in ECMAScript objects, only Function objects implement [[FormalParameterList]]. |
| [[Code]] | ECMAScript code | The ECMAScript code of a function. Of the standard built-in ECMAScript objects, only Function objects implement [[Code]]. |
| [[TargetFunction]] | Object | The target function of a function object created using the standard built-in Function.prototype.bind method. Only ECMAScript objects created using Function.prototype.bind have a [[TargetFunction]] internal property. |
| [[BoundThis]] | <i>any</i> | The pre-bound this value of a function Object created using the standard built-in Function.prototype.bind method. Only ECMAScript objects created using Function.prototype.bind have a [[BoundThis]] internal property. |
| [[BoundArguments]] | List of <i>any</i> | The pre-bound argument values of a function Object created using the standard built-in Function.prototype.bind method. Only ECMAScript objects created using Function.prototype.bind have a [[BoundArguments]] internal property. |
| [[Match]] | SpecOp(<i>string</i> , <i>index</i>) → <i>MatchResult</i> | Tests for a regular expression match and returns a MatchResult value (see section 15.10.2.1). Of the standard built-in ECMAScript objects, only RegExp objects implement [[Match]]. |
| [[ParameterMap]] | Object | Provides a mapping between the properties of an arguments object (10.6) and the formal parameters of the associated function. Only ECMAScript objects that are arguments objects have a [[ParameterMap]] internal property. |

8.7 The Reference Specification Type

The Reference type is used to explain the behaviour of such operators as **delete**, **typeof**, and the assignment operators. For example, the left-hand operand of an assignment is expected to produce a reference. The behaviour of assignment could, instead, be explained entirely in terms of a case analysis on the syntactic form of the left-hand operand of an assignment operator, but for one difficulty: function calls are permitted to return references. This possibility is admitted purely for the sake of host objects. No built-in ECMAScript function defined by this specification returns a reference and there is no provision for a user-defined function to return a reference. (Another reason not to use a syntactic case analysis is that it would be lengthy and awkward, affecting many parts of the specification.)

A **Reference** is a resolved name binding. A Reference consists of three components, the *base* value, the *referenced name* and the Boolean valued *strict reference* flag. The base value is either **undefined**, an Object, a Boolean, a String, a Number, or an environment record (10.2.1). A base value of **undefined** indicates that the reference could not be resolved to a binding. The referenced name is a String.

The following abstract operations are used in this specification to access the components of references:

- **GetBase(V)**. Returns the base value component of the reference *V*.
- **GetReferencedName(V)**. Returns the referenced name component of the reference *V*.
- **IsStrictReference(V)**. Returns the strict reference component of the reference *V*.
- **HasPrimitiveBase(V)**. Returns **true** if the base value is a Boolean, String, or Number.
- **IsPropertyReference(V)**. Returns **true** if either the base value is an object or **HasPrimitiveBase(V)** is **true**; otherwise returns **false**.
- **IsUnresolvableReference(V)**. Returns **true** if the base value is **undefined** and **false** otherwise.

The following abstract operations are used in this specification to operate on references:

8.7.1 **GetValue (V)**

1. If **Type(V)** is not **Reference**, return *V*.
2. Let *base* be the result of calling **GetBase(V)**.
3. If **IsUnresolvableReference(V)**, throw a **ReferenceError** exception.
4. If **IsPropertyReference(V)**, then
 - a. If **HasPrimitiveBase(V)**, then let *base* be **ToObject(base)** (section 9.9).
 - b. Return the result of calling the **[[Get]]** internal method of *base*, passing **GetReferencedName(V)** for the argument.
5. Else, *base* must be an environment record.
 - a. Return the result of calling the **GetBindingValue** (section 10.2.1) concrete method of *base* passing **GetReferencedName(V)** and **IsStrictReference(V)** as arguments.

NOTE

The object that may be created in step 4.a is immediately discarded after its use in the next step. An implementation might choose to avoid the actual creation of the object.

8.7.2 **PutValue (V, W)**

1. If **Type(V)** is not **Reference**, throw a **ReferenceError** exception.
2. Let *base* be the result of calling **GetBase(V)**.
3. If **IsUnresolvableReference(V)**, then
 - a. If **IsStrictReference(V)** is **true**, then
 - i. Throw **ReferenceError** exception.
 - b. Call the **[[Put]]** internal method of the global object, passing **GetReferencedName(V)** for the property name, *W* for the value, and **false** for the *Throw* flag.
4. Else if **IsPropertyReference(V)**, then
 - a. If **HasPrimitiveBase(V)** is **false**, then let *put* be the **[[Put]]** internal method of *base*, otherwise let *put* be the special **[[Put]]** internal method defined below.
 - b. Call the *put* internal method using *base* as its **this** object, and passing **GetReferencedName(V)** for the property name, *W* for the value, and **IsStrictReference(V)** for the *Throw* flag.
5. Else *base* must be a reference whose base is an environment record. So,
 - a. Call the **SetMutableBinding** (10.2.1) concrete method of *base*, passing **GetReferencedName(V)**, *W*, and **IsStrictReference(V)** as arguments.
6. Return.

The following **[[Put]]** internal method is used by **PutValue** when *V* is a property reference with a primitive base value. It is called using *base* as its **this** value and with property *P*, value *W*, and boolean flag *Throw* as arguments. The following steps are taken:

1. Let *O* be **ToObject(base)**.
2. If the result of calling the **[[CanPut]]** internal method of *O* with argument *P* is **false**, then
 - a. If *Throw* is **true**, then throw a **TypeError** exception.
 - b. Else return.

3. Let *ownDesc* be the result of calling the `[[GetOwnProperty]]` internal method of *O* with argument *P*.
4. If `IsDataDescriptor(ownDesc)` is **true**, then
 - a. If *Throw* is **true**, then throw a **TypeError** exception.
 - b. Else Return.
5. Let *desc* be the result of calling the `[[GetProperty]]` internal method of *O* with argument *P*. This may be either an own or inherited accessor property descriptor or an inherited data property descriptor.
6. If `IsAccessorDescriptor(desc)` is **true**, then
 - a. Let *setter* be *desc*.`[[Set]]` which cannot be **undefined**.
 - b. Call the `[[Call]]` internal method of *setter* providing *Base* as the **this** value and an argument list containing only *W*.
7. Else, this is a request to create an own property on the transient object *O*
 - a. If *Throw* is **true**, then throw a **TypeError** exception.
8. Return.

NOTE

The object that may be created in step 1 is not accessible outside of the above method. An implementation might choose to avoid the actual creation of that transient object. The only situations where such an actual property assignment that uses this internal method can have visible effect are when it either invokes an accessor function or is in violation of a Throw predicated error check. When Throw is true any property assignment that would create a new property on the transient object throws an error.

8.8 The List Specification Type

The List type is used to explain the evaluation of argument lists (see 11.2.4) in **new** expressions, in function calls, and in other algorithms where a simple list of values is needed. Values of the List type are simply ordered sequences of values. These sequences may be of any length.

8.9 The Completion Specification Type

The Completion type is used to explain the behaviour of statements (**break**, **continue**, **return** and **throw**) that perform nonlocal transfers of control. Values of the Completion type are triples of the form (*type*, *value*, *target*), where *type* is one of **normal**, **break**, **continue**, **return**, or **throw**, *value* is any ECMAScript language value or **empty**, and *target* is any ECMAScript identifier or **empty**.

The term “abrupt completion” refers to any completion with a type other than **normal**.

8.10 The Property Descriptor and Property Identifier Specification Types

The Property Descriptor type is used to explain the manipulation and reification of named property attributes. Values of the Property Descriptor type are records composed of named fields where each field’s name is an attribute name and its value is a corresponding attribute value as specified in 8.6.1. In addition, any field may be present or absent.

Property Descriptor values may be further classified as data property descriptors and accessor property descriptors based upon the existence or use of certain fields. A data property descriptor is one that includes any fields named either `[[Value]]` or `[[Writable]]`. An accessor property descriptor is one that includes any fields named either `[[Get]]` or `[[Set]]`. Any property descriptor may have fields named `[[Enumerable]]` and `[[Configurable]]`. A Property Descriptor value may not be both a data property descriptor and an accessor property descriptor; however, it may be neither. A generic property descriptor is a Property Descriptor value that is neither a data property descriptor nor an accessor property descriptor. A fully populated property descriptor is one that is either an accessor property descriptor or a data property descriptor and that has all of the fields that correspond to the property attributes defined in either 8.6.1 Table 1 or Table 2.

For notational convenience within this specification, an object literal-like syntax can be used to define a property descriptor value. For example, Property Descriptor `{[[Value]]: 42, [[Writable]]: false, [[Configurable]]: true}` defines a data property descriptor. Field name order is not significant. Any fields that are not explicitly listed are considered to be absent.

In specification text and algorithms, dot notation may be used to refer to a specific field of a Property Descriptor. For example, if *D* is a property descriptor then *D*.`[[Value]]` is short hand for “the field of *D* named `[[Value]]`”.

The Property Identifier type is used to associate a property name with a Property Descriptor. Values of the Property Identifier type are pairs of the form (name, descriptor), where name is a string and descriptor is a Property Descriptor value.

The following abstract operations are used in this specification to operate upon Property Descriptor values:

8.10.1 IsAccessorDescriptor (Desc)

When the abstract operation IsAccessorDescriptor is called with property descriptor *Desc*, the following steps are taken:

1. If *Desc* is **undefined**, then return **false**.
2. If both *Desc*.[[Get]] and *Desc*.[[Set]] are absent, then return **false**.
3. Return **true**.

8.10.2 IsDataDescriptor (Desc)

When the abstract operation IsDataDescriptor is called with property descriptor *Desc*, the following steps are taken:

1. If *Desc* is **undefined**, then return **false**.
2. If both *Desc*.[[Value]] and *Desc*.[[Writable]] are absent, then return **false**.
3. Return **true**.

8.10.3 IsGenericDescriptor (Desc)

When the abstract operation IsGenericDescriptor is called with property descriptor *Desc*, the following steps are taken:

1. If *Desc* is **undefined**, then return **false**.
2. If IsAccessorDescriptor(*Desc*) and IsDataDescriptor(*Desc*) are both **false**, then return **true**.
3. Return **false**.

8.10.4 FromPropertyDescriptor (Desc)

When the abstract operation FromPropertyDescriptor is called with property descriptor *Desc*, the following steps are taken:

The following algorithm assumes that *Desc* is a fully populated Property Descriptor, such as that returned from [[GetOwnProperty]] (8.12.1).

1. If *Desc* is **undefined**, then return **undefined**.
2. Let *obj* be the result of creating a new object as if by the expression **new Object()** where **Object** is the standard built-in constructor with that name.
3. If IsDataDescriptor(*Desc*) is **true**, then
 - a. Call the [[DefineOwnProperty]] internal method of *obj* with arguments "**value**", Property Descriptor {[Value]: *Desc*.[[Value]], [Writable]: **true**, [Enumerable]: **true**, [Configurable]: **true**}, and **false**.
 - b. Call the [[DefineOwnProperty]] internal method of *obj* with arguments "**writable**", Property Descriptor {[Value]: *Desc*.[[Writable]], [Writable]: **true**, [Enumerable]: **true**, [Configurable]: **true**}, and **false**.
4. Else, IsAccessorDescriptor(*Desc*) must be **true**, so
 - a. Call the [[DefineOwnProperty]] internal method of *obj* with arguments "**get**", Property Descriptor {[Value]: *Desc*.[[Get]], [Writable]: **true**, [Enumerable]: **true**, [Configurable]: **true**}, and **false**.
 - b. Call the [[DefineOwnProperty]] internal method of *obj* with arguments "**set**", Property Descriptor {[Value]: *Desc*.[[Set]], [Writable]: **true**, [Enumerable]: **true**, [Configurable]: **true**}, and **false**.
5. Call the [[DefineOwnProperty]] internal method of *obj* with arguments "**enumerable**", Property Descriptor {[Value]: *Desc*.[[Enumerable]], [Writable]: **true**, [Enumerable]: **true**, [Configurable]: **true**}, and **false**.
6. Call the [[DefineOwnProperty]] internal method of *obj* with arguments "**configurable**", Property Descriptor {[Value]: *Desc*.[[Configurable]], [Writable]: **true**, [Enumerable]: **true**, [Configurable]: **true**}, and **false**.
7. Return *obj*.

8.10.5 ToPropertyDescriptor (Obj)

When the abstract operation ToPropertyDescriptor is called with object *Desc*, the following steps are taken:

1. If Type(*Obj*) is not Object throw a **TypeError** exception.
2. Let *desc* be the result of creating a new Property Descriptor that initially has no fields.
3. If the result of calling the [[HasProperty]] internal method of *Obj* with argument "enumerable" is **true**, then
 - a. Let *enum* be the result of calling the [[Get]] internal method of *Obj* with "enumerable".
 - b. Set the [[Enumerable]] field of *desc* to ToBoolean(*enum*).
4. If the result of calling the [[HasProperty]] internal method of *Obj* with argument "configurable" is **true**, then
 - a. Let *conf* be the result of calling the [[Get]] internal method of *Obj* with argument "configurable".
 - b. Set the [[Configurable]] field of *desc* to ToBoolean(*conf*).
5. If the result of calling the [[HasProperty]] internal method of *Obj* with argument "value" is **true**, then
 - a. Let *value* be the result of calling the [[Get]] internal method of *Obj* with argument "value".
 - b. Set the [[Value]] field of *desc* to *value*.
6. If the result of calling the [[HasProperty]] internal method of *Obj* with argument "writable" is **true**, then
 - a. Let *writable* be the result of calling the [[Get]] internal method of *Obj* with argument "writable".
 - b. Set the [[Writable]] field of *desc* to ToBoolean(*writable*).
7. If the result of calling the [[HasProperty]] internal method of *Obj* with argument "get" is **true**, then
 - a. Let *getter* be the result of calling the [[Get]] internal method of *Obj* with argument "get".
 - b. If IsCallable(*getter*) is **false** and *getter* is not **undefined**, then throw a **TypeError** exception.
 - c. Set the [[Get]] field of *desc* to *getter*.
8. If the result of calling the [[HasProperty]] internal method of *Obj* with argument "set" is **true**, then
 - a. Let *setter* be the result of calling the [[Get]] internal method of *Obj* with argument "set".
 - b. If IsCallable(*setter*) is **false** and *setter* is not **undefined**, then throw a **TypeError** exception.
 - c. Set the [[Set]] field of *desc* to *setter*.
9. If either *desc*.[[Get]] or *desc*.[[Set]] are present, then
 - a. If either *desc*.[[Value]] or *desc*.[[Writable]] are present, then throw a **TypeError** exception.
10. Return *desc*.

8.11 The Lexical Environment and Environment Record Specification Types

The Lexical Environment and Environment Record types are used to explain the behaviour of name resolution in nested functions and blocks. These types and the operations upon them are defined in section 10.

8.12 Algorithms for Object Internal Methods

In the following algorithm descriptions, assume *O* is a native ECMAScript object, *P* is a string, *Desc* is a Property Description record, and *Throw* is a Boolean flag.

8.12.1 [[GetOwnProperty]] (P)

When the [[GetOwnProperty]] internal method of *O* is called with property name *P*, the following steps are taken:

1. If *O* doesn't have an own property with name *P*, return **undefined**.
2. Let *D* be a newly created Property Descriptor (Section 8.10) with no fields.
3. Let *X* be *O*'s own property named *P*.
4. If *X* is a data property, then
 - a. Set *D*.[[Value]] to the value of *X*'s [[Value]] attribute.
 - b. Set *D*.[[Writable]] to the value of *X*'s [[Writable]] attribute
5. Else *X* is an accessor property, so
 - a. Set *D*.[[Get]] to the value of *X*'s [[Get]] attribute.
 - b. Set *D*.[[Set]] to the value of *X*'s [[Set]] attribute.

6. Set $D.[[Enumerable]]$ to the value of X 's $[[Enumerable]]$ attribute.
7. Set $D.[[Configurable]]$ to the value of X 's $[[Configurable]]$ attribute.
8. Return D .

Note, however, that if O is a String object it has a more elaborate $[[GetOwnProperty]]$ internal method (15.5.5.2).

8.12.2 $[[GetProperty]]$ (P)

When the $[[GetProperty]]$ internal method of O is called with property name P , the following steps are taken:

1. Let $prop$ be the result of calling the $[[GetOwnProperty]]$ internal method of O with property name P .
2. If $prop$ is not **undefined**, return $prop$.
3. Let $proto$ be the value of the $[[Prototype]]$ internal property of O .
4. If $proto$ is **null**, return **undefined**.
5. Return the result of calling the $[[GetProperty]]$ internal method of $proto$ with argument P .

8.12.3 $[[Get]]$ (P)

When the $[[Get]]$ internal method of O is called with property name P , the following steps are taken:

1. Let $desc$ be the result of calling the $[[GetProperty]]$ internal method of O with property name P .
2. If $desc$ is **undefined**, return **undefined**.
3. If $IsDataDescriptor(desc)$ is **true**, return $desc.[[Value]]$.
4. Otherwise, $IsAccessorDescriptor(desc)$ must be true so, let $getter$ be $desc.[[Get]]$.
5. If $getter$ is **undefined**, return **undefined**.
6. Return the result calling the $[[Call]]$ internal method of $getter$ providing O as the **this** value and providing no arguments.

8.12.4 $[[CanPut]]$ (P)

When the $[[CanPut]]$ internal method of O is called with property name P , the following steps are taken:

1. Let $desc$ be the result of calling the $[[GetOwnProperty]]$ internal method of O with argument P .
2. If $desc$ is not **undefined**, then
 - a. If $IsAccessorDescriptor(desc)$ is **true**, then
 - i. If $desc.[[Set]]$ is **undefined**, then return **false**.
 - ii. Else return **true**.
 - b. Else, $desc$ must be a $DataDescriptor$ so return the value of $desc.[[Writable]]$.
3. Let $proto$ be the $[[Prototype]]$ internal property of O .
4. If $proto$ is **null**, then return the value of the $[[Extensible]]$ internal property of O .
5. Let $inherited$ be the result of calling the $[[GetProperty]]$ internal method of $proto$ with property name P .
6. If $inherited$ is **undefined**, return the value of the $[[Extensible]]$ internal property of O .
7. If $IsAccessorDescriptor(inherited)$ is **true**, then
 - a. If $inherited.[[Set]]$ is **undefined**, then return **false**.
 - b. Else return **true**.
8. Else, $inherited$ must be a $DataDescriptor$
 - a. If the $[[Extensible]]$ internal property of O is **false**, return **false**.
 - b. Else return the value of $inherited.[[Writable]]$.

NOTE

Host objects may define additional constraints upon $[[Put]]$ operations. If possible, host objects should not allow $[[Put]]$ operations in situations where this definition of $[[CanPut]]$ returns false.

8.12.5 $[[Put]]$ (P, V, Throw)

When the $[[Put]]$ internal method of O is called with property P , value V , and boolean flag $Throw$, the following steps are taken:

1. If the result of calling the $[[CanPut]]$ internal method of O with argument P is **false**, then
 - a. If $Throw$ is **true**, then throw a **TypeError** exception.
 - b. Else return.
2. Let $ownDesc$ be the result of calling the $[[GetOwnProperty]]$ internal method of O with argument P .

3. If `IsDataDescriptor(ownDesc)` is **true**, then
 - a. Let *valueDesc* be the Property Descriptor `{[[Value]]: V}`.
 - b. Call the `[[DefineOwnProperty]]` internal method of *O* passing *P*, *valueDesc*, and *Throw* as arguments.
 - c. Return.
4. Let *desc* be the result of calling the `[[GetProperty]]` internal method of *O* with argument *P*. This may be either an own or inherited accessor property descriptor or an inherited data property descriptor.
5. If `IsAccessorDescriptor(desc)` is **true**, then
 - a. Let *setter* be *desc*.`[[Set]]` which cannot be **undefined**.
 - b. Call the `[[Call]]` internal method of *setter* providing *O* as the **this** value and providing *V* as the sole argument.
6. Else, create a named data property named *P* on object *O* as follows
 - a. Let *newDesc* be the Property Descriptor `{[[Value]]: V, [[Writable]]: true, [[Enumerable]]: true, [[Configurable]]: true}`.
 - b. Call the `[[DefineOwnProperty]]` internal method of *O* passing *P*, *newDesc*, and *Throw* as arguments.
7. Return.

8.12.6 `[[HasProperty]]` (**P**)

When the `[[HasProperty]]` internal method of *O* is called with property name *P*, the following steps are taken:

Let *desc* be the result of calling the `[[GetProperty]]` internal method of *O* with property name *P*.
 If *desc* is **undefined**, then return **false**.
 Else return **true**.

8.12.7 `[[Delete]]` (**P, Throw**)

When the `[[Delete]]` internal method of *O* is called with property name *P* and the boolean flag *Throw*, the following steps are taken:

1. Let *desc* be the result of calling the `[[GetOwnProperty]]` internal method of *O* with property name *P*.
2. If *desc* is **undefined**, then return **true**.
3. If *desc*.`[[Configurable]]` is **true**, then
 - a. Remove the own property with name *P* from *O*.
 - b. Return **true**.
4. Else if *Throw*, then throw a **TypeError** exception.
5. Return **false**.

8.12.8 `[[DefaultValue]]` (**hint**)

When the `[[DefaultValue]]` internal method of *O* is called with hint String, the following steps are taken:

1. Let *toString* be the result of calling the `[[Get]]` internal method of object *O* with argument **"toString"**.
2. If `IsCallable(toString)` is **true** then,
 - a. Let *str* be the result of calling the `[[Call]]` internal method of *toString*, with *O* as the **this** value and an empty argument list.
 - b. If *str* is a primitive value, return *str*.
3. Let *valueOf* be the result of calling the `[[Get]]` internal method of object *O* with argument **"valueOf"**.
4. If `IsCallable(valueOf)` is **true** then,
 - a. Let *val* be the result of calling the `[[Call]]` internal method of *valueOf*, with *O* as the **this** value and an empty argument list.
 - b. If *val* is a primitive value, return *val*.
5. Throw a **TypeError** exception.

When the `[[DefaultValue]]` internal method of *O* is called with hint Number, the following steps are taken:

1. Let *valueOf* be the result of calling the `[[Get]]` internal method of object *O* with argument **"valueOf"**.

2. If `IsCallable(valueOf)` is **true** then,
 - a. Let *val* be the result of calling the `[[Call]]` internal method of *valueOf*, with *O* as the **this** value and an empty argument list.
 - b. If *val* is a primitive value, return *val*.
3. Let *toString* be the result of calling the `[[Get]]` internal method of object *O* with argument **"toString"**.
4. If `IsCallable(toString)` is **true** then,
 - a. Let *str* be the result of calling the `[[Call]]` internal method of *toString*, with *O* as the **this** value and an empty argument list.
 - b. If *str* is a primitive value, return *str*.
5. Throw a **TypeError** exception.

When the `[[DefaultValue]]` internal method of *O* is called with no hint, then it behaves as if the hint were Number, unless *O* is a Date object (see 15.9.6), in which case it behaves as if the hint were String.

The above specification of `[[DefaultValue]]` for native objects can return only primitive values. If a host object implements its own `[[DefaultValue]]` internal method, it must ensure that its `[[DefaultValue]]` internal method can return only primitive values.

8.12.9 `[[DefineOwnProperty]]` (*P*, *Desc*, *Throw*)

In the following algorithm, the term “Reject” means “If *Throw* is **true**, then throw a **TypeError** exception, otherwise return **false**.”

When the `[[DefineOwnProperty]]` internal method of *O* is called with property name *P*, property descriptor *Desc*, and boolean flag *Throw*, the following steps are taken:

1. Let *current* be the result of calling the `[[GetOwnProperty]]` internal method of *O* with property name *P*.
2. Let *extensible* be the value of the `[[Extensible]]` internal property of *O*.
3. If *current* is **undefined** and *extensible* is **false**, then Reject.
4. If *current* is **undefined** and *extensible* is **true**, then
 - a. If `IsGenericDescriptor(Desc)` or `IsDataDescriptor(Desc)` is **true**, then
 - i. Create an own data property named *P* of object *O* whose `[[Value]]`, `[[Writable]]`, `[[Enumerable]]` and `[[Configurable]]` attribute values are described by *Desc*. If the value of an attribute field of *Desc* is absent, the attribute of the newly created property is set to its default value.
 - b. Else, *Desc* must be an accessor Property Descriptor so,
 - i. Create an own accessor property named *P* of object *O* whose `[[Get]]`, `[[Set]]`, `[[Enumerable]]` and `[[Configurable]]` attribute values are described by *Desc*. If the value of an attribute field of *Desc* is absent, the attribute of the newly created property is set to its default value.
 - c. Return **true**.
5. Return **true**, if every field in *Desc* is absent.
6. Return **true**, if every field in *Desc* also occurs in *current* and the value of every field in *Desc* is the same value as the corresponding field in *current* when compared using the `SameValue` algorithm (9.12).
7. If the `[[Configurable]]` field of *current* is **false** then
 - a. Reject, if the `[[Configurable]]` field of *Desc* is **true**.
 - b. Reject, if the `[[Enumerable]]` fields of *current* and *Desc* are the Boolean negation of each other.
8. If `IsGenericDescriptor(Desc)` is **true**, then no further validation is required.
9. Else, if `IsDataDescriptor(current)` and `IsDataDescriptor(Desc)` have different results, then
 - a. Reject, if the `[[Configurable]]` field of *current* is **false**.
 - b. If `IsDataDescriptor(current)` is **true**, then
 - i. Convert the property named *P* of object *O* from a data property to an accessor property. Preserve the existing values of the converted property’s `[[Configurable]]` and `[[Enumerable]]` attributes and set the rest of the property’s attributes to their default values.
 - c. Else,

- i. Convert the property named *P* of object *O* from an accessor property to a data property. Preserve the existing values of the converted property's `[[Configurable]]` and `[[Enumerable]]` attributes and set the rest of the property's attributes to their default values.
- 10. Else, if `IsDataDescriptor(current)` and `IsDataDescriptor(Desc)` are both **true**, then
 - a. If the `[[Configurable]]` field of *current* is **false**, then
 - i. Reject, if the `[[Writable]]` field of *current* is **false** and the `[[Writable]]` field of *Desc* is **true**.
 - ii. If the `[[Writable]]` field of *current* is **false**, then
 - 1. Reject, if the `[[Value]]` field of *Desc* is present and `SameValue(Desc.[[Value]], current.[[Value]])` is **false**.
 - b. else, the `[[Configurable]]` field of *current* is **true**, so any change is acceptable.
- 11. Else, `IsAccessorDescriptor(current)` and `IsAccessorDescriptor(Desc)` are both **true** so,
 - a. If the `[[Configurable]]` field of *current* is **false**, then
 - i. Reject, if the `[[Set]]` field of *Desc* is present and `SameValue(Desc.[[Set]], current.[[Set]])` is **false**.
 - ii. Reject, if the `[[Get]]` field of *Desc* is present and `SameValue(Desc.[[Get]], current.[[Get]])` is **false**.
- 12. For each attribute field of *Desc* that is present, set the correspondingly named attribute of the property named *P* of object *O* to the value of the field.
- 13. Return **true**.

However, if *O* is an Array object, it has a more elaborate `[[DefineOwnProperty]]` internal method (15.4.5.1).

NOTE

The above algorithm contains steps that test various fields of the Property Descriptor Desc for specific values. The fields that are tested in this manner need not actually exist in Desc. If a field is absent then the result of any test of its value is logically false.

*Step 10.b allows any field of Desc to be different from the corresponding field of current if current's `[[Configurable]]` field is **true**. This even permits changing the `[[Value]]` of a property whose `[[Writable]]` attribute is **false**. This is allowed because a **true** `[[Configurable]]` attribute would permit an equivalent sequence of calls where `[[Writable]]` is first set to **true**, a new `[[Value]]` is set, and then `[[Writable]]` is set to **false**.*

9 Type Conversion and Testing

The ECMAScript runtime system performs automatic type conversion as needed. To clarify the semantics of certain constructs it is useful to define a set of conversion abstract operations. These abstract operations are not a part of the language; they are defined here to aid the specification of the semantics of the language. The conversion abstract operations are polymorphic; that is, they can accept a value of any ECMAScript language type, but not of specification types.

9.1 ToPrimitive

The abstract operation ToPrimitive takes an *input* argument and an optional argument *PreferredType*. The abstract operation ToPrimitive converts its *input* argument to a non-Object type. If an object is capable of converting to more than one primitive type, it may use the optional hint *PreferredType* to favour that type. Conversion occurs according to the following table:

| <i>Input Type</i> | <i>Result</i> |
|-------------------|---|
| Undefined | The result equals the <i>input</i> argument (no conversion). |
| Null | The result equals the <i>input</i> argument (no conversion). |
| Boolean | The result equals the <i>input</i> argument (no conversion). |
| Number | The result equals the <i>input</i> argument (no conversion). |
| String | The result equals the <i>input</i> argument (no conversion). |
| Object | Return a default value for the Object. The default value of an object is retrieved by calling the <code>[[DefaultValue]]</code> internal method of the object, passing the optional hint <i>PreferredType</i> . The behaviour of the <code>[[DefaultValue]]</code> internal method is defined by this specification for all native ECMAScript objects (8.12.8). |

9.2 ToBoolean

The abstract operation ToBoolean converts its argument to a value of type Boolean according to the following table:

| <i>Argument Type</i> | <i>Result</i> |
|----------------------|---|
| Undefined | false |
| Null | false |
| Boolean | The result equals the input argument (no conversion). |
| Number | The result is false if the argument is +0 , -0 , or NaN ; otherwise the result is true . |
| String | The result is false if the argument is the empty string (its length is zero); otherwise the result is true . |
| Object | true |

9.3 ToNumber

The abstract operation ToNumber converts its argument to a value of type Number according to the following table:

| <i>Argument Type</i> | <i>Result</i> |
|----------------------|---|
| Undefined | NaN |
| Null | +0 |
| Boolean | The result is 1 if the argument is true . The result is +0 if the argument is false . |
| Number | The result equals the input argument (no conversion). |
| String | See grammar and note below. |
| Object | Apply the following steps: 1. Let <i>primValue</i> be ToPrimitive(input argument, hint Number). 2. Return ToNumber(<i>primValue</i>). |

9.3.1 ToNumber Applied to the String Type

ToNumber applied to strings applies the following grammar to the input string. If the grammar cannot interpret the string as an expansion of *StringNumericLiteral*, then the result of ToNumber is **NaN**.

StringNumericLiteral :::

*StrWhiteSpace*_{opt}

*StrWhiteSpace*_{opt} *StrNumericLiteral* *StrWhiteSpace*_{opt}

StrWhiteSpace :::

StrWhiteSpaceChar *StrWhiteSpace*_{opt}

StrWhiteSpaceChar :::

WhiteSpace

LineTerminator

StrNumericLiteral :::

StrDecimalLiteral

HexIntegerLiteral

StrDecimalLiteral :::

StrUnsignedDecimalLiteral

+ *StrUnsignedDecimalLiteral*

- *StrUnsignedDecimalLiteral*

StrUnsignedDecimalLiteral :::

Infinity

DecimalDigits **.** *DecimalDigits*_{opt} *ExponentPart*_{opt}

. *DecimalDigits* *ExponentPart*_{opt}

DecimalDigits *ExponentPart*_{opt}

DecimalDigits :::

DecimalDigit

DecimalDigits *DecimalDigit*

DecimalDigit ::: **one of**

0 1 2 3 4 5 6 7 8 9

ExponentPart :::

ExponentIndicator *SignedInteger*

ExponentIndicator ::: **one of**

e E

SignedInteger :::
DecimalDigits
+ *DecimalDigits*
- *DecimalDigits*

HexIntegerLiteral :::
0x *HexDigit*
0X *HexDigit*
HexIntegerLiteral *HexDigit*

HexDigit ::: one of
0 1 2 3 4 5 6 7 8 9 a b c d e f A B C D E F

Some differences should be noted between the syntax of a *StringNumericLiteral* and a *NumericLiteral* (see 7.8.3):

- A *StringNumericLiteral* may be preceded and/or followed by white space and/or line terminators.
- A *StringNumericLiteral* that is decimal may have any number of leading 0 digits.
- A *StringNumericLiteral* that is decimal may be preceded by + or - to indicate its sign.
- A *StringNumericLiteral* that is empty or contains only white space is converted to +0.

The conversion of a string to a number value is similar overall to the determination of the number value for a numeric literal (see 7.8.3), but some of the details are different, so the process for converting a string numeric literal to a value of Number type is given here in full. This value is determined in two steps: first, a mathematical value (MV) is derived from the string numeric literal; second, this mathematical value is rounded as described below.

- The MV of *StringNumericLiteral* ::: [empty] is 0.
- The MV of *StringNumericLiteral* ::: *StrWhiteSpace* is 0.
- The MV of *StringNumericLiteral* ::: *StrWhiteSpace*_{opt} *StrNumericLiteral* *StrWhiteSpace*_{opt} is the MV of *StrNumericLiteral*, no matter whether white space is present or not.
- The MV of *StrNumericLiteral* ::: *StrDecimalLiteral* is the MV of *StrDecimalLiteral*.
- The MV of *StrNumericLiteral* ::: *HexIntegerLiteral* is the MV of *HexIntegerLiteral*.
- The MV of *StrDecimalLiteral* ::: *StrUnsignedDecimalLiteral* is the MV of *StrUnsignedDecimalLiteral*.
- The MV of *StrDecimalLiteral* ::: + *StrUnsignedDecimalLiteral* is the MV of *StrUnsignedDecimalLiteral*.
- The MV of *StrDecimalLiteral* ::: - *StrUnsignedDecimalLiteral* is the negative of the MV of *StrUnsignedDecimalLiteral*. (Note that if the MV of *StrUnsignedDecimalLiteral* is 0, the negative of this MV is also 0. The rounding rule described below handles the conversion of this signless mathematical zero to a floating-point +0 or -0 as appropriate.)
- The MV of *StrUnsignedDecimalLiteral* ::: **Infinity** is 10¹⁰⁰⁰⁰ (a value so large that it will round to +∞).
- The MV of *StrUnsignedDecimalLiteral* ::: *DecimalDigits* . is the MV of *DecimalDigits*.
- The MV of *StrUnsignedDecimalLiteral* ::: *DecimalDigits* . *DecimalDigits* is the MV of the first *DecimalDigits* plus (the MV of the second *DecimalDigits* times 10⁻ⁿ), where n is the number of characters in the second *DecimalDigits*.
- The MV of *StrUnsignedDecimalLiteral* ::: *DecimalDigits* . *ExponentPart* is the MV of *DecimalDigits* times 10^e, where e is the MV of *ExponentPart*.
- The MV of *StrUnsignedDecimalLiteral* ::: *DecimalDigits* . *DecimalDigits* *ExponentPart* is (the MV of the first *DecimalDigits* plus (the MV of the second *DecimalDigits* times 10⁻ⁿ)) times 10^e, where n is the number of characters in the second *DecimalDigits* and e is the MV of *ExponentPart*.
- The MV of *StrUnsignedDecimalLiteral* ::: . *DecimalDigits* is the MV of *DecimalDigits* times 10⁻ⁿ, where n is the number of characters in *DecimalDigits*.
- The MV of *StrUnsignedDecimalLiteral* ::: . *DecimalDigits* *ExponentPart* is the MV of *DecimalDigits* times 10^{e-n}, where n is the number of characters in *DecimalDigits* and e is the MV of *ExponentPart*.

- The MV of *StrUnsignedDecimalLiteral*::: *DecimalDigits* is the MV of *DecimalDigits*.
- The MV of *StrUnsignedDecimalLiteral*::: *DecimalDigits ExponentPart* is the MV of *DecimalDigits* times 10^e , where e is the MV of *ExponentPart*.
- The MV of *DecimalDigits* ::: *DecimalDigit* is the MV of *DecimalDigit*.
- The MV of *DecimalDigits* ::: *DecimalDigits DecimalDigit* is (the MV of *DecimalDigits* times 10) plus the MV of *DecimalDigit*.
- The MV of *ExponentPart* ::: *ExponentIndicator SignedInteger* is the MV of *SignedInteger*.
- The MV of *SignedInteger* ::: *DecimalDigits* is the MV of *DecimalDigits*.
- The MV of *SignedInteger* ::: + *DecimalDigits* is the MV of *DecimalDigits*.
- The MV of *SignedInteger* ::: - *DecimalDigits* is the negative of the MV of *DecimalDigits*.
- The MV of *DecimalDigit* ::: 0 or of *HexDigit* ::: 0 is 0.
- The MV of *DecimalDigit* ::: 1 or of *HexDigit* ::: 1 is 1.
- The MV of *DecimalDigit* ::: 2 or of *HexDigit* ::: 2 is 2.
- The MV of *DecimalDigit* ::: 3 or of *HexDigit* ::: 3 is 3.
- The MV of *DecimalDigit* ::: 4 or of *HexDigit* ::: 4 is 4.
- The MV of *DecimalDigit* ::: 5 or of *HexDigit* ::: 5 is 5.
- The MV of *DecimalDigit* ::: 6 or of *HexDigit* ::: 6 is 6.
- The MV of *DecimalDigit* ::: 7 or of *HexDigit* ::: 7 is 7.
- The MV of *DecimalDigit* ::: 8 or of *HexDigit* ::: 8 is 8.
- The MV of *DecimalDigit* ::: 9 or of *HexDigit* ::: 9 is 9.
- The MV of *HexDigit* ::: a or of *HexDigit* ::: A is 10.
- The MV of *HexDigit* ::: b or of *HexDigit* ::: B is 11.
- The MV of *HexDigit* ::: c or of *HexDigit* ::: C is 12.
- The MV of *HexDigit* ::: d or of *HexDigit* ::: D is 13.
- The MV of *HexDigit* ::: e or of *HexDigit* ::: E is 14.
- The MV of *HexDigit* ::: f or of *HexDigit* ::: F is 15.
- The MV of *HexIntegerLiteral* ::: 0x *HexDigit* is the MV of *HexDigit*.
- The MV of *HexIntegerLiteral* ::: 0X *HexDigit* is the MV of *HexDigit*.
- The MV of *HexIntegerLiteral* ::: *HexIntegerLiteral HexDigit* is (the MV of *HexIntegerLiteral* times 16) plus the MV of *HexDigit*.

Once the exact MV for a string numeric literal has been determined, it is then rounded to a value of the Number type. If the MV is 0, then the rounded value is +0 unless the first non white space character in the string numeric literal is '-', in which case the rounded value is -0. Otherwise, the rounded value must be the number value for the MV (in the sense defined in 8.5), unless the literal includes a *StrUnsignedDecimalLiteral* and the literal has more than 20 significant digits, in which case the number value may be either the number value for the MV of a literal produced by replacing each significant digit after the 20th with a 0 digit or the number value for the MV of a literal produced by replacing each significant digit after the 20th with a 0 digit and then incrementing the literal at the 20th digit position. A digit is *significant* if it is not part of an *ExponentPart* and

- it is not 0; or
- there is a nonzero digit to its left and there is a nonzero digit, not in the *ExponentPart*, to its right.

9.4 ToInteger

The abstract operation ToInteger converts its argument to an integral numeric value. This abstract operation functions as follows:

1. Let *number* be the result of calling ToNumber on the input argument.
2. If *number* is NaN, return +0.
3. If *number* is +0, -0, +∞, or -∞, return *number*.
4. Return the result of computing $\text{sign}(\text{number}) * \text{floor}(\text{abs}(\text{number}))$.

9.5 ToInt32: (Signed 32 Bit Integer)

The abstract operation ToInt32 converts its argument to one of 2^{32} integer values in the range -2^{31} through $2^{31}-1$, inclusive. This abstract operation functions as follows:

1. Let *number* be the result of calling ToNumber on the input argument.
2. If *number* is NaN, +0, -0, +∞, or -∞, return +0.
3. Let *posInt* be $\text{sign}(\text{number}) * \text{floor}(\text{abs}(\text{number}))$.
4. Let *int32bit* be *posInt* modulo 2^{32} ; that is, a finite integer value *k* of Number type with positive sign and less than 2^{32} in magnitude such that the mathematical difference of *posInt* and *k* is mathematically an integer multiple of 2^{32} .
5. If *int32bit* is greater than or equal to 2^{31} , return $\text{int32bit} - 2^{32}$, otherwise return *int32bit*.

NOTE

Given the above definition of ToInt32:

The ToInt32 abstract operation is idempotent: if applied to a result that it produced, the second application leaves that value unchanged.

$\text{ToInt32}(\text{ToUint32}(x))$ is equal to $\text{ToInt32}(x)$ for all values of *x*. (It is to preserve this latter property that +∞ and -∞ are mapped to +0.)

ToInt32 maps -0 to +0.

9.6 ToUint32: (Unsigned 32 Bit Integer)

The abstract operation ToUint32 converts its argument to one of 2^{32} integer values in the range 0 through $2^{32}-1$, inclusive. This abstraction operator functions as follows:

1. Let *number* be the result of calling ToNumber on the input argument.
2. If *number* is NaN, +0, -0, +∞, or -∞, return +0.
3. Let *posInt* be $\text{sign}(\text{number}) * \text{floor}(\text{abs}(\text{number}))$.
4. Let *int32bit* be *posInt* modulo 2^{32} ; that is, a finite integer value *k* of Number type with positive sign and less than 2^{32} in magnitude such that the mathematical difference of *posInt* and *k* is mathematically an integer multiple of 2^{32} .
5. Return *int32bit*.

NOTE

Given the above definition of ToUint32:

Step 5 is the only difference between ToUint32 and ToInt32.

The ToUint32 abstract operation is idempotent: if applied to a result that it produced, the second application leaves that value unchanged.

$\text{ToUint32}(\text{ToInt32}(x))$ is equal to $\text{ToUint32}(x)$ for all values of *x*. (It is to preserve this latter property that +∞ and -∞ are mapped to +0.)

ToUint32 maps -0 to +0.

9.7 ToUint16: (Unsigned 16 Bit Integer)

The abstract operation ToUint16 converts its argument to one of 2^{16} integer values in the range 0 through $2^{16}-1$, inclusive. This abstract operation functions as follows:

1. Let *number* be the result of calling ToNumber on the input argument.
2. If *number* is NaN, +0, -0, +∞, or -∞, return +0.
3. Let *posInt* be $\text{sign}(\text{number}) * \text{floor}(\text{abs}(\text{number}))$.
4. Let *int16bit* be *posInt* modulo 2^{16} ; that is, a finite integer value *k* of Number type with positive sign and less than 2^{16} in magnitude such that the mathematical difference of *posInt* and *k* is mathematically an integer multiple of 2^{16} .
5. Return *int16bit*.

NOTE

Given the above definition of *ToUint16*:

The substitution of 2^{16} for 2^{32} in step 4 is the only difference between *ToUint32* and *ToUint16*.

ToUint16 maps -0 to $+0$.

9.8 ToString

The abstract operation *ToString* converts its argument to a value of type *String* according to the following table:

| Argument Type | Result |
|---------------|---|
| Undefined | "undefined" |
| Null | "null" |
| Boolean | If the argument is true , then the result is " true ". If the argument is false , then the result is " false ". |
| Number | See 9.8.1 below. |
| String | Return the input argument (no conversion) |
| Object | Apply the following steps: 1. Let <i>primValue</i> be <i>ToPrimitive</i> (input argument, hint <i>String</i>). 2. Return <i>ToString</i> (<i>primValue</i>). |

9.8.1 ToString Applied to the Number Type

The abstract operation *ToString* converts a number *m* to string format as follows:

1. If *m* is **NaN**, return the string "**NaN**".
2. If *m* is **+0** or **-0**, return the string "**0**".
3. If *m* is less than zero, return the string concatenation of the string **"-"** and *ToString*($-m$).
4. If *m* is infinity, return the string "**Infinity**".
5. Otherwise, let *n*, *k*, and *s* be integers such that $k \geq 1$, $10^{k-1} \leq s < 10^k$, the number value for $s \times 10^{n-k}$ is *m*, and *k* is as small as possible. Note that *k* is the number of digits in the decimal representation of *s*, that *s* is not divisible by 10, and that the least significant digit of *s* is not necessarily uniquely determined by these criteria.
6. If $k \leq n \leq 21$, return the string consisting of the *k* digits of the decimal representation of *s* (in order, with no leading zeroes), followed by $n-k$ occurrences of the character '0'.
7. If $0 < n \leq 21$, return the string consisting of the most significant *n* digits of the decimal representation of *s*, followed by a decimal point '.', followed by the remaining $k-n$ digits of the decimal representation of *s*.
8. If $-6 < n \leq 0$, return the string consisting of the character '0', followed by a decimal point '.', followed by $-n$ occurrences of the character '0', followed by the *k* digits of the decimal representation of *s*.
9. Otherwise, if $k = 1$, return the string consisting of the single digit of *s*, followed by lowercase character 'e', followed by a plus sign '+' or minus sign '-' according to whether $n-1$ is positive or negative, followed by the decimal representation of the integer $\text{abs}(n-1)$ (with no leading zeros).
10. Return the string consisting of the most significant digit of the decimal representation of *s*, followed by a decimal point '.', followed by the remaining $k-1$ digits of the decimal representation of *s*, followed by the lowercase character 'e', followed by a plus sign '+' or minus sign '-' according to whether $n-1$ is positive or negative, followed by the decimal representation of the integer $\text{abs}(n-1)$ (with no leading zeros).

NOTE

The following observations may be useful as guidelines for implementations, but are not part of the normative requirements of this Standard:

If *x* is any number value other than **-0**, then *ToNumber*(*ToString*(*x*)) is exactly the same number value as *x*.

The least significant digit of s is not always uniquely determined by the requirements listed in step 5.

For implementations that provide more accurate conversions than required by the rules above, it is recommended that the following alternative version of step 5 be used as a guideline:

Otherwise, let n , k , and s be integers such that $k \geq 1$, $10^{k-1} \leq s < 10^k$, the number value for $s \times 10^{n-k}$ is m , and k is as small as possible. If there are multiple possibilities for s , choose the value of s for which $s \times 10^{n-k}$ is closest in value to m . If there are two such possible values of s , choose the one that is even. Note that k is the number of digits in the decimal representation of s and that s is not divisible by 10.

Implementers of ECMAScript may find useful the paper and code written by David M. Gay for binary-to-decimal conversion of floating-point numbers:

Gay, David M. *Correctly Rounded Binary-Decimal and Decimal-Binary Conversions*. Numerical Analysis Manuscript 90-10. AT&T Bell Laboratories (Murray Hill, New Jersey). November 30, 1990. Available as <http://cm.bell-labs.com/cm/cs/doc/90/4-10.ps.gz>. Associated code available as <http://cm.bell-labs.com/netlib/fp/dtoa.c.gz> and as http://cm.bell-labs.com/netlib/fp/g_fmt.c.gz and may also be found at the various **netlib** mirror sites.

9.9 ToObject

The abstract operation ToObject converts its argument to a value of type Object according to the following table:

| Argument Type | Result |
|---------------|--|
| Undefined | Throw a TypeError exception. |
| Null | Throw a TypeError exception. |
| Boolean | Create a new Boolean object whose <code>[[PrimitiveValue]]</code> internal property is set to the value of the boolean. See 15.6 for a description of Boolean objects. |
| Number | Create a new Number object whose <code>[[PrimitiveValue]]</code> internal property is set to the value of the number. See 15.7 for a description of Number objects. |
| String | Create a new String object whose <code>[[PrimitiveValue]]</code> internal property is set to the value of the string. See 15.5 for a description of String objects. |
| Object | The result is the input argument (no conversion). |

9.10 CheckObjectCoercible

The abstract operation CheckObjectCoercible throws an error if its argument is a value that cannot be converted to an Object using ToObject. It is defined by the following table:

| Argument Type | Result |
|---------------|-------------------------------------|
| Undefined | Throw a TypeError exception. |
| Null | Throw a TypeError exception. |
| Boolean | Return |
| Number | Return |
| String | Return |
| Object | Return |

9.11 IsCallable

The abstract operation IsCallable determines if its argument, which must be an ECMAScript language value, is a callable function Object according to the following table:

| <i>Argument Type</i> | <i>Result</i> |
|----------------------|--|
| Undefined | Return false . |
| Null | Return false . |
| Boolean | Return false . |
| Number | Return false . |
| String | Return false . |
| Object | If the argument object has an <code>[[Call]]</code> internal method, then return true , otherwise return false . |

9.12 The SameValue Algorithm

The internal comparison abstract operation `SameValue(x, y)`, where x and y are ECMAScript language values, produces **true** or **false**. Such a comparison is performed as follows:

1. If `Type(x)` is different from `Type(y)`, return **false**.
2. If `Type(x)` is `Undefined`, return **true**.
3. If `Type(x)` is `Null`, return **true**.
4. If `Type(x)` is `Number`, then
 - a. If x is `NaN` and y is `NaN`, return **true**.
 - b. If x is `+0` and y is `-0`, return **false**.
 - c. If x is `-0` and y is `+0`, return **false**.
 - d. If x is the same number value as y , return **true**.
 - e. Return **false**.
5. If `Type(x)` is `String`, then return **true** if x and y are exactly the same sequence of characters (same length and same characters in corresponding positions); otherwise, return **false**.
6. If `Type(x)` is `Boolean`, return **true** if x and y are both **true** or both **false**; otherwise, return **false**.
7. Return **true** if x and y refer to the same object. Otherwise, return **false**.

10 Executable Code and Execution Contexts

10.1 Types of Executable Code

There are three types of ECMAScript executable code:

- *Global code* is source text that is treated as an ECMAScript *Program*. The global code of a particular *Program* does not include any source text that is parsed as part of a *FunctionBody*.
- *Eval code* is the source text supplied to the built-in **eval** function. More precisely, if the parameter to the built-in **eval** function is a string, it is treated as an ECMAScript *Program*. The eval code for a particular invocation of **eval** is the global code portion of that *Program*.
- *Function code* is source text that is parsed as part of a *FunctionBody*. The *function code* of a particular *FunctionBody* does not include any source text that is parsed as part of a nested *FunctionBody*. *Function code* also denotes the source text supplied when using the built-in **Function** object as a constructor. More precisely, the last parameter provided to the **Function** constructor is converted to a string and treated as the *FunctionBody*. If more than one parameter is provided to the **Function** constructor, all parameters except the last one are converted to strings and concatenated together, separated by commas. The resulting string is interpreted as the *FormalParameterList* for the *FunctionBody* defined by the last parameter. The function code for a particular instantiation of a **Function** does not include any source text that is parsed as part of a nested *FunctionBody*.

10.1.1 Strict Mode Code

An ECMAScript *Program* syntactic unit may be processed using either unrestricted or strict mode syntax and semantics. When processed using strict mode the three types of ECMAScript code are referred to as strict global code, strict eval code, and strict function code. Code is interpreted in strict mode code in the following situations:

- Global code is strict global code if the *Program* that defines the global code includes a Use Strict Directive (14.1).
- Eval code is strict eval code if it is a *Program* that includes a Use Strict Directive (14.1) or if the call to eval is a direct call (see section 15.1.2.1.1) to the eval function that is contained in strict mode code.
- Function code that is part of a *FunctionDeclaration* or *FunctionExpression* is strict function code if its *FunctionDeclaration* or *FunctionExpression* is contained in strict mode code or if its *FunctionBody* includes a Use Strict Directive (14.1).
- Function code that is supplied as the last argument to the built-in **Function** constructor is strict function code if the last argument is a string that when processed as a *FunctionBody* includes a Use Strict Directive (14.1).

10.2 Lexical Environments

A *Lexical Environment* is a specification type used to define the association of *Identifiers* to specific variables and functions based upon the lexical nesting structure of ECMAScript code. A *Lexical Environment* consists of an *Environment Record* and a possibly null reference to an *outer* *Lexical Environment*. Usually a *Lexical Environment* is associated with some specific syntactic structure of ECMAScript code such as a *FunctionDeclaration*, a *WithStatement*, or a *catch* clause of a *TryStatement* and a new *Lexical Environment* is created each time such code is evaluated.

An *Environment Record* records the identifier bindings that are created within the scope of its associated *Lexical Environment*.

The outer environment reference is used to model the logical nesting of *Lexical Environment* values. The outer reference of a (inner) *Lexical Environment* is a reference to the *Lexical Environment* that logically surrounds the inner *Lexical Environment*. An outer *Lexical Environment* may, of course, have its own outer *Lexical Environment*. A *Lexical Environment* may serve as the outer environment for multiple inner *Lexical Environments*. For example, if a *FunctionDeclaration* contains two nested *FunctionDeclarations*

then the Lexical Environments of each of the nested functions will have as their outer Lexical Environment the Lexical Environment of the current execution of the surrounding function.

Lexical Environments and Environment Record values are purely specification mechanisms and need not correspond to any specific artefact of an ECMAScript implementation. It is impossible for an ECMAScript program to directly access or manipulate such values.

10.2.1 Environment Records

There are two kinds of Environment Record values used in this specification: *declarative environment records* and *object environment records*. Declarative environment records are used to define the effect of ECMAScript language syntactic elements such as *FunctionDeclarations*, *VariableDeclarations*, and *Catch* clauses that directly associate **identifier** bindings with ECMAScript language values. Object environment records are used to define the effect of ECMAScript elements such as *Program* and *WithStatement* that associate **identifier** bindings with the properties of some object.

For specification purposes Environment Record values can be thought of as existing in a simple object-oriented hierarchy where Environment Record is an abstract class with two concrete subclasses, declarative environment record and object environment record. The abstract class defines the following abstract specification methods that have distinct concrete algorithms for each of its subclasses:

| <i>Method</i> | <i>Purpose</i> |
|----------------------------|---|
| HasBinding(N) | Determine if an environment record has a binding for an identifier. Return true if it does and false if it does not. The string value <i>N</i> is the text of the identifier. |
| CreateMutableBinding(N, D) | Create a new mutable binding in an environment record. The string value <i>N</i> is the text of the bound name. If the optional Boolean argument <i>D</i> is true the binding is may be subsequently deleted. |
| SetMutableBinding(N, V, S) | Set the value of an already existing mutable binding in an environment record. The string value <i>N</i> is the text of the bound name. <i>V</i> is the value for the binding and may be a value of any ECMAScript language type. <i>S</i> is a Boolean flag. If <i>S</i> is true and the binding cannot be set throw a TypeError exception. <i>S</i> is used to identify strict mode references. |
| GetBindingValue(N, S) | Returns the value of an already existing binding from an environment record. The string value <i>N</i> is the text of the bound name. <i>S</i> is used to identify strict mode references. If <i>S</i> is true and the binding does not exist or is uninitialized throw a ReferenceError exception. |
| DeleteBinding(N) | Delete a binding from an environment record. The string value <i>N</i> is the text of the bound name. If a binding for <i>N</i> exists, remove the binding and return true . If the binding exists but cannot be removed return false . If the binding does not exist return true . |
| ImplicitThisValue() | Returns the value to use as the this value on calls to function objects that are obtained as binding values from this environment record. |

10.2.1.1 Declarative Environment Records

Each declarative environment record is associated with an ECMAScript program scope containing variable and/or function declarations. A declarative environment record binds the set of identifiers defined by the declarations contained within its scope.

In addition to the mutable bindings supported by all Environment Records, declarative environment records also provide for immutable bindings. An immutable binding is one where the association between an identifier and a value may not be modified once it has been established. Creation and initialization of immutable binding are distinct steps so it is possible for such bindings to exist in either an initialized or uninitialized state. Declarative environment records support the following methods in addition to the Environment Record abstract specification methods:

| <i>Method</i> | <i>Purpose</i> |
|---------------------------------|---|
| CreateImmutableBinding(N) | Create a new but uninitialized immutable binding in an environment record. The string value <i>N</i> is the text of the bound name. |
| InitializeImmutableBinding(N,V) | Set the value of an already existing but uninitialized immutable binding in an environment record. The string value <i>N</i> is the text of the bound name. <i>V</i> is the value for the binding and is a value of any ECMAScript language type. |

The behaviour of the concrete specification methods for Declarative Environment Records are defined by the following algorithms.

10.2.1.1.1 HasBinding(*N*)

The concrete environment record method HasBinding for declarative environment records simply determines if the argument identifier is one of the identifiers bound by the record:

1. Let *envRec* be the declarative environment record for which the method was invoked.
2. If *envRec* has a binding for the name that is the value of *N*, return **true**.
3. If it does not have such a binding, return **false**.

10.2.1.1.2 CreateMutableBinding (*N*, *D*)

The concrete Environment Record method CreateMutableBinding for declarative environment records creates a new mutable binding for the name *N* that is initialized to the value **undefined**. A binding must not already exist in this Environment Record for *N*. If Boolean argument *D* is provided and has the value **true** the new binding is marked as being subject to deletion.

1. Let *envRec* be the declarative environment record for which the method was invoked.
2. Assert: *envRec* does not already have a binding for *N*.
3. Create a mutable binding in *envRec* for *N* and set its bound value to **undefined**. If *D* is true record that the newly created binding may be deleted by a subsequent DeleteBinding call.

10.2.1.1.3 SetMutableBinding (*N*,*V*,*S*)

The concrete Environment Record method SetMutableBinding for declarative environment records attempts to change the bound value of the current binding of the identifier whose name is the value of the argument *N* to the value of argument *V*. A binding for *N* must already exist. If the binding is an immutable binding, a **TypeError** is always thrown. The *S* argument is ignored because strict mode does not change the meaning of setting bindings in declarative environment records.

1. Let *envRec* be the declarative environment record for which the method was invoked.
2. Assert: *envRec* must have a binding for *N*.
3. If the binding for *N* in *envRec* is a mutable binding, change its bound value to *V*.
4. Else this must be an attempt to change the value of an immutable binding so throw a **TypeError** exception.

10.2.1.1.4 GetBindingValue(*N*,*S*)

The concrete Environment Record method GetBindingValue for declarative environment records simply returns the value of its bound identifier whose name is the value of the argument *N*. The binding must already exist. If *S* is **true** and the binding is an uninitialized immutable binding throw a **ReferenceError** exception.

1. Let *envRec* be the declarative environment record for which the method was invoked.
2. Assert: *envRec* has a binding for *N*.
3. If the binding for *N* in *envRec* is an uninitialized immutable binding, then
 - a. If *S* is **false**, return the value **undefined**, otherwise throw a **ReferenceError** exception.
4. Else, return the value currently bound to *N* in *envRec*.

10.2.1.1.5 DeleteBinding (*N*)

The concrete Environment Record method DeleteBinding for declarative environment records can only delete bindings that have been explicitly designated as being subject to deletion.

1. Let *envRec* be the declarative environment record for which the method was invoked.
2. If *envRec* does not have a binding for the name that is the value of *N*, return **true**.
3. If the binding for *N* in *envRec* is cannot be deleted, return **false**.
4. Remove the binding for *N* from *envRec*.
5. Return **true**.

10.2.1.1.6 ImplicitThisValue()

Declarative Environment Records always return **undefined** as their `ImplicitThisValue`.

1. Return **undefined**.

10.2.1.1.7 CreateImmutableBinding (N)

The concrete Environment Record method `CreateImmutableBinding` for declarative environment records creates a new immutable binding for the name *N* that is initialized to the value **undefined**. A binding must not already exist in this environment record for *N*.

1. Let *envRec* be the declarative environment record for which the method was invoked.
2. Assert: *envRec* does not already have a binding for *N*.
3. Create an immutable binding in *envRec* for *N* and record that it is uninitialized.

10.2.1.1.8 InitializeImmutableBinding (N,V)

The concrete Environment Record method `InitializeImmutableBinding` for declarative environment records is used to set the bound value of the current binding of the identifier whose name is the value of the argument *N* to the value of argument *V*. An uninitialized immutable binding for *N* must already exist.

1. Let *envRec* be the declarative environment record for which the method was invoked.
2. Assert: *envRec* must have an uninitialized immutable binding for *N*.
3. Set the bound value for *N* in *envRec* to *V*.
4. Record that the immutable binding for *N* in *envRec* has been initialized.

10.2.1.2 Object Environment Records

Each object environment record is associated with an object called its *binding object*. An object environment record binds the set of identifier names that directly correspond to the property names of its binding object. Property names that are not an *IdentifierName* are not included in the set of bound identifiers. Both own and inherited properties are included in the set regardless of the setting of their `[[Enumerable]]` attribute. Because properties can be dynamically added and deleted from objects, the set of identifiers bound by an object environment record may potentially change as a side-effect of any operation that adds or deletes properties. Any bindings that are created as a result of such a side-effect are considered to be a mutable binding even if the `Writable` attribute of the corresponding property has the value **false**. Immutable bindings do not exist for object environment records.

Object environment records can be configured to provide their binding object as an implicit this value for use in function calls. This capability is used to specify the behaviour of `With Statement` (12.10) induced bindings. The capability is controlled by a *provideThis* Boolean value that is associated with each object environment record. By default, the value of *provideThis* is **false** for any object environment record.

The behaviour of the concrete specification methods for Object Environment Records is defined by the following algorithms.

10.2.1.2.1 HasBinding(N)

The concrete Environment Record method `HasBinding` for object environment records determines if its associated binding object has a property whose name is the value of the argument *N*:

1. Let *envRec* be the object environment record for which the method was invoked.
2. Let *bindings* be the binding object for *envRec*.
3. Return the result of calling the `[[HasProperty]]` internal method of *bindings*, passing *N* as the property name.

10.2.1.2.2 CreateMutableBinding (N, D)

The concrete Environment Record method `CreateMutableBinding` for object environment records creates in an environment record's associated binding object a property whose name is the string value *N* and initializes it to the value **undefined**. A property named *N* must not already exist in the binding object. If Boolean argument *D* is provided and has the value **true** the new property's `[[Configurable]]` attribute is set to **true**, otherwise it is set to **false**.

1. Let *envRec* be the object environment record for which the method was invoked.
2. Let *bindings* be the binding object for *envRec*.
3. Assert: The result of calling the `[[HasProperty]]` internal method of *bindings*, passing *N* as the property name, is **false**.
4. If *D* is **true** then let *configValue* be **true** otherwise let *configValue* be **false**.
5. Call the `[[DefineOwnProperty]]` internal method of *bindings*, passing *N*, Property Descriptor `{[[Value]]: undefined, [[Writable]]: true, [[Enumerable]]: true, [[Configurable]]: configValue}`, and **false** as arguments.

10.2.1.2.3 SetMutableBinding (N,V,S)

The concrete Environment Record method `SetMutableBinding` for object environment records attempts to set the value of the environment record's associated binding object's property whose name is the value of the argument *N* to the value of argument *V*. A property named *N* should already exist but if it does not or is not currently writable, error handling is determined by the value of the Boolean argument *S*.

1. Let *envRec* be the object environment record for which the method was invoked.
2. Let *bindings* be the binding object for *envRec*.
3. Call the `[[Put]]` internal method of *bindings* with arguments *N*, *V*, and *S*.

10.2.1.2.4 GetBindingValue(N,S)

The concrete Environment Record method `GetBindingValue` for object environment records returns the value of its associated binding object's property whose name is the string value of the argument identifier *N*. The property should already exist but if it does not the result depends upon the value of the *S* argument:

1. Let *envRec* be the object environment record for which the method was invoked.
2. Let *bindings* be the binding object for *envRec*.
3. Let *value* be the result of calling the `[[HasProperty]]` internal method of *bindings*, passing *N* as the property name.
4. If *value* is **false**, then
 - a. If *S* is **false**, return the value **undefined**, otherwise throw a **ReferenceError** exception.
5. Return the result of calling the `[[Get]]` internal method of *bindings*, passing *N* for the argument.

10.2.1.2.5 DeleteBinding (N)

The concrete Environment Record method `DeleteBinding` for object environment records can only delete bindings that correspond to properties of the environment object whose `[[Configurable]]` attribute have the value **true**.

1. Let *envRec* be the object environment record for which the method was invoked.
2. Let *bindings* be the binding object for *envRec*.
3. Return the result of calling the `[[Delete]]` internal method of *bindings*, passing *N* and **false** as arguments.

10.2.1.2.6 ImplicitThisValue()

Object Environment Records return **undefined** as their `ImplicitThisValue` unless their `provideThis` flag is **true**.

1. Let *envRec* be the object environment record for which the method was invoked.
2. If the `provideThis` flag of *envRec* is **true**, return the binding object for *envRec*.
3. Otherwise, return **undefined**.

10.2.2 Lexical Environment Operations

The following abstract operations are used in this specification to operate upon lexical environments:

10.2.2.1 GetIdentifierReference (lex, name, strict)

The abstract operation GetIdentifierReference is called with a Lexical Environment *lex*, an identifier string *name*, and a boolean flag *strict*. The value of *lex* may be **null**. When called, the following steps are performed:

1. If *lex* is the value **null**, then
 - a. Return a value of type Reference whose base value is **undefined**, whose referenced name is *name*, and whose strict mode flag is *strict*.
2. Let *envRec* be *lex*'s environment record.
3. Let *exists* be the result of calling the HasBinding(*N*) concrete method of *envRec* passing *name* as the argument *N*.
4. If *exists* is **true**, then
 - a. Return a value of type Reference whose base value is *envRec*, whose referenced name is *name*, and whose strict mode flag is *strict*.
5. Else
 - a. Let *outer* be the value of *lex*'s outer environment reference.
 - b. Return the result of calling GetIdentifierReference passing *outer*, *name*, and *strict* as arguments.

10.2.2.2 NewDeclarativeEnvironment (E)

When the abstract operation NewDeclarativeEnvironment is called with either a Lexical Environment or **null** as argument *E* the following steps are performed:

1. Let *env* be a new Lexical Environment.
2. Let *envRec* be a new declarative environment record containing no bindings.
3. Set *env*'s environment record to be *envRec*.
4. Set the outer lexical environment reference of *env* to *E*.
5. Return *env*.

10.2.2.3 NewObjectEnvironment (O, E)

When the abstract operation NewObjectEnvironment is called with an Object *O* and a Lexical Environment *E* (or **null**) as arguments, the following steps are performed:

1. Let *env* be a new Lexical Environment.
2. Let *envRec* be a new object environment record containing *O* as the binding object.
3. Set *env*'s environment record to be *envRec*.
4. Set the outer lexical environment reference of *env* to *E*.
5. Return *env*.

10.2.3 The Global Environment

The *global environment* is a unique Lexical Environment which is created before any ECMAScript code is executed. The global environment's Environment Record is an object environment record whose binding object is the global object (15.1). The global environment's outer environment reference is **null**.

As ECMAScript code is executed, additional properties may be added to the global object and the initial properties may be modified.

10.3 Execution Contexts

When control is transferred to ECMAScript executable code, control is entering an *execution context*. Active execution contexts logically form a stack. The top execution context on this logical stack is the running execution context. A new execution context is created whenever control is transferred from the executable code associated with the currently running execution context to executable code that is not associated with that execution context. The newly created execution context is pushed onto the stack and becomes the running execution context.

An execution context contains whatever state is necessary to track the execution progress of its associated code. In addition, each execution context has the following state components:

| <i>Component</i> | <i>Purpose</i> |
|---------------------|--|
| LexicalEnvironment | Identifies the Lexical Environment used to resolve identifier references made by code within this execution context. |
| VariableEnvironment | Identifies the Lexical Environment whose environment record holds bindings created by <i>VariableStatements</i> and <i>FunctionDeclarations</i> within this execution context. |
| ThisBinding | The value associated with the this keyword within ECMAScript code associated with this execution context. |

The LexicalEnvironment and VariableEnvironment components of an execution context are always Lexical Environments. When an execution context is created its LexicalEnvironment and VariableEnvironment components initially have the same value. The value of the VariableEnvironment component never changes while the value of the LexicalEnvironment component may change during execution of code within an execution context.

In most situations only the running execution context (the top of the execution context stack) is directly manipulated by algorithms within this specification. Hence when the terms “LexicalEnvironment”, “VariableEnvironment” and “ThisBinding” are used without qualification they are in reference to those components of the running execution context.

An execution context is purely a specification mechanism and need not correspond to any particular artefact of an ECMAScript implementation. It is impossible for an ECMAScript program to access an execution context.

10.3.1 Identifier Resolution

Identifier resolution is the process of determining the binding of an *Identifier* using the LexicalEnvironment of the running execution context. During execution of ECMAScript code, the syntactic production *PrimaryExpression* : *Identifier* is evaluated using the following algorithm:

1. Let *env* be the running execution context’s LexicalEnvironment.
2. If the syntactic production that is being evaluated is contained in a strict mode code, then let *strict* be **true** else let *strict* be **false**.
3. Return the result of calling GetIdentifierReference function passing *env*, *Identifier*, and *strict* as arguments.

The result of evaluating an identifier is always a value of type Reference with its referenced name component equal to the *Identifier* string.

10.4 Establishing an Execution Context

Evaluation of global code or code using the eval function (15.1.2.1) establishes and enters a new execution context. Every invocation of an ECMAScript code function (13.2.1) also establishes and enters a new execution context, even if a function is calling itself recursively. Every return exits an execution context. A thrown exception may also exit one or more execution contexts.

When control enters an execution context, the execution context’s ThisBinding is set, its VariableEnvironment and initial LexicalEnvironment are defined, and declaration binding instantiation (10.5) is performed. The exact manner in which these actions occur depend on the type of code being entered.

10.4.1 Global Code

The following steps are performed when control enters the execution context for global code:

1. Initialize the execution context using the global code as described in 10.4.1.1.
2. Perform Declaration Binding Instantiation as described in 10.5 using the global code.

10.4.1.1 Initial Global Execution Context

The following steps are performed to initialize a global execution context for ECMAScript code C:

1. Set the VariableEnvironment to the Global Environment.
2. Set the LexicalEnvironment to the Global Environment.

3. Set the `ThisBinding` to the global object.

10.4.2 Eval Code

The following steps are performed when control enters the execution context for eval code:

1. If there is no calling context or if the eval code is not being evaluated by a direct call (15.1.2.1.1) to the eval function then,
 - a. Initialize the execution context as if it was a global execution context using the eval code as *C* as described in 10.4.1.1.
2. Else,
 - a. Set the `ThisBinding` to the same value as the `ThisBinding` of the calling execution context.
 - b. Set the `LexicalEnvironment` to the same value as the `LexicalEnvironment` of the calling execution context.
 - c. Set the `VariableEnvironment` to the same value as the `VariableEnvironment` of the calling execution context.
3. If the eval code is strict code, then
 - a. Let *strictVarEnv* be the result of calling `NewDeclarativeEnvironment` passing the `LexicalEnvironment` as the argument.
 - b. Set the `LexicalEnvironment` to *strictVarEnv*.
 - c. Set the `VariableEnvironment` to *strictVarEnv*.
4. Perform Declaration Binding Instantiation as described in 10.5 using the eval code.

10.4.2.1 Strict Mode Restrictions

The eval code cannot instantiate variable or function bindings in the variable environment of the calling context that invoked the eval if either the code of the calling context or the eval code is strict code. Instead such bindings are instantiated in a new `VariableEnvironment` that is only accessible to the eval code.

10.4.3 Function Code

The following steps are performed when control enters the execution context for function code contained in function object *F*, a caller provided *thisArg*, and a caller provided *argumentsList*:

1. If the function code is strict code, set the `ThisBinding` to *thisArg*.
2. Else if *thisArg* is **null** or **undefined**, set the `ThisBinding` to the global object.
3. Else if *thisArg* is not an Object, set the `ThisBinding` to `ToObject(thisArg)`.
4. Else set the `ThisBinding` to *thisArg*.
5. Let *localEnv* be the result of calling `NewDeclarativeEnvironment` passing the value of the `[[Scope]]` internal property of *F* as the argument.
6. Set the `LexicalEnvironment` to *localEnv*.
7. Set the `VariableEnvironment` to *localEnv*.
8. Let *code* be the value of *F*'s `[[Code]]` internal property.
9. Perform Declaration Binding Instantiation using the function code *code* and *argumentsList* as described in 10.5.

10.5 Declaration Binding Instantiation

Every execution context has an associated `VariableEnvironment`. Variables and functions declared in ECMAScript code evaluated in an execution context are added as bindings in that `VariableEnvironment`'s `Environment Record`. For function code, parameters are also added as bindings to that `Environment Record`.

Which `Environment Record` is used to bind a declaration and its kind depends upon the type of ECMAScript code executed by the execution context, but the remainder of the behaviour is generic. On entering an execution context, bindings are created in the `VariableEnvironment` as follows using the caller provided *code* and, if it is function code, argument List *args*:

1. Let *env* be the environment record component of the running execution context's `VariableEnvironment`.
2. If *code* is eval code, then let *configurableBindings* be **true** else let *configurableBindings* be **false**.
3. If *code* is strict mode code, then let *strict* be **true** else let *strict* be **false**.
4. If *code* is function code, then

- a. Let *func* be the function whose [[Call]] internal method initiated execution of *code*. Let *names* be the value of *func*'s [[FormalParameters]] internal property.
 - b. Let *argCount* be the number of elements in *args*.
 - c. Let *n* be the number 0.
 - d. For each string *argName* in *names*, in list order do
 - i. Let *n* be the current value of *n* plus 1.
 - ii. If *n* is greater than *argCount*, let *v* be **undefined** otherwise let *v* be the value of the *n*'th element of *args*.
 - iii. Let *argAlreadyDeclared* be the result of calling *env*'s HasBinding concrete method passing *argName* as the argument.
 - iv. If *argAlreadyDeclared* is **false**, call *env*'s CreateMutableBinding concrete method passing *argName* as the argument.
 - v. Call *env*'s SetMutableBinding concrete method passing *argName*, *v*, and *strict* as the arguments.
5. For each *FunctionDeclaration* *f* in *code*, in source text order do
 - a. Let *fn* be the *Identifier* in *FunctionDeclaration* *f*.
 - b. Let *fo* be the result of instantiating *FunctionDeclaration* *f* as described in section 13.
 - c. Let *funcAlreadyDeclared* be the result of calling *env*'s HasBinding concrete method passing *fn* as the argument.
 - d. If *funcAlreadyDeclared* is **false**, call *env*'s CreateMutableBinding concrete method passing *fn* and *configurableBindings* as the arguments.
 - e. Call *env*'s SetMutableBinding concrete method passing *fn*, *fo*, and *strict* as the arguments.
 6. For each *VariableDeclaration* and *VariableDeclarationNoIn* *d* in *code*, in source text order do
 - a. Let *dn* be the *Identifier* in *d*.
 - b. Let *varAlreadyDeclared* be the result of calling *env*'s HasBinding concrete method passing *dn* as the argument.
 - c. If *varAlreadyDeclared* is **false**, then
 - i. Call *env*'s CreateMutableBinding concrete method passing *dn* and *configurableBindings* as the arguments.
 - ii. Call *env*'s SetMutableBinding concrete method passing *dn*, **undefined**, and *strict* as the arguments.
 7. Let *argumentsAlreadyDeclared* be the result of calling *env*'s HasBinding concrete method passing **"arguments"** as the argument
 8. If *code* is function code and *argumentsAlreadyDeclared* is **false**, then
 - a. Let *argsObj* be the result of calling the abstract operation CreateArgumentsObject (10.6) passing *func*, *names*, *args*, *env* and *strict* as arguments.
 - b. If *strict* is **true**, then
 - i. Call *env*'s CreateImmutableBinding concrete method passing the string **"arguments"** as the argument.
 - ii. Call *env*'s InitializeImmutableBinding concrete method passing **"arguments"** and *argsObj* as arguments.
 - c. Else,
 - i. Call *env*'s CreateMutableBinding concrete method passing the string **"arguments"** as the argument.
 - ii. Call *env*'s SetMutableBinding concrete method passing **"arguments"**, *argsObj*, and **false** as arguments.

10.6 Arguments Object

When control enters an execution context for function code, an arguments object is created unless (section 10.5) the identifier **arguments** occurs as an *Identifier* in the function's *FormalParameterList* or as the *Identifier* of *VariableDeclaration* or *FunctionDeclaration* contained in the function code.

The arguments object is created by calling the abstract operation CreateArgumentsObject with arguments *func* the function object whose code is to be evaluated, *names* a List containing the function's formal parameter names, *args* the actual arguments passed to the [[Call]] internal method, *env* the variable environment for the function code, and *strict* a Boolean that indicates whether or not the function code is strict code. When CreateArgumentsObject is called the following steps are performed:

1. Let *len* be the number of elements in *args*.
2. Let *obj* be the result of creating a new ECMAScript object.
3. Set the `[[Class]]` internal property of *obj* to **"Arguments"**.
4. Let *Object* be the standard built-in Object constructor (15.2.3).
5. Set the `[[Prototype]]` internal property of *obj* to the standard built-in Array prototype object (15.4.4).
6. Call the `[[DefineOwnProperty]]` internal method on *obj* passing **"constructor"**, the Property Descriptor `{[[Value]]: Object, [[Writable]]: true, [[Enumerable]]: false, [[Configurable]]: true}`, and **false** as arguments.
7. Let *toString* be the arguments object **toString** method defined below.
8. Let *toLocaleString* be the arguments object **toLocaleString** method defined below.
9. Call the `[[DefineOwnProperty]]` internal method on *obj* passing **"toString"**, the Property Descriptor `{[[Value]]: toString, [[Writable]]: true, [[Enumerable]]: false, [[Configurable]]: true}`, and **false** as arguments.
10. Call the `[[DefineOwnProperty]]` internal method on *obj* passing **"toLocaleString"**, the Property Descriptor `{[[Value]]: toLocaleString, [[Writable]]: true, [[Enumerable]]: false, [[Configurable]]: true}`, and **false** as arguments.
11. Call the `[[DefineOwnProperty]]` internal method on *obj* passing **"length"**, the Property Descriptor `{[[Value]]: len, [[Writable]]: true, [[Enumerable]]: false, [[Configurable]]: true}`, and **false** as arguments.
12. Let *map* be the result of creating a new object as if by the expression **new Object()** where **Object** is the standard built-in constructor with that name
13. Let *mappedNames* be an empty List.
14. Let *indx* = *len* - 1.
15. Repeat while *indx* >= 0,
 - a. Let *val* be the element of *args* at 0-origin list position *indx*.
 - b. Call the `[[DefineOwnProperty]]` internal method on *obj* passing `Tostring(indx)`, the property descriptor `{[[Value]]: val, [[Writable]]: true, [[Enumerable]]: true, [[Configurable]]: true}`, and **false** as arguments.
 - c. If *indx* is less than the number of elements in *names*, then
 - i. Let *name* be the element of *names* at 0-origin list position *indx*.
 - ii. If *strict* is **false** and *name* is not an element of *mappedNames*, then
 1. Add *name* as an element of the list *mappedNames*.
 2. Let *g* be the result of calling the *MakeArgGetter* abstract operation with arguments *name* and *env*.
 3. Let *p* be the result of calling the *MakeArgSetter* abstract operation with arguments *name* and *env*.
 4. Call the `[[DefineOwnProperty]]` internal method of *map* passing `Tostring(indx)`, the Property Descriptor `{[[Set]]: p, [[Get]]: g, [[Configurable]]: true}`, and **false** as arguments.
 - d. Let *indx* = *indx* - 1
16. If *mappedNames* is not empty, then
 - a. Set the `[[ParameterMap]]` internal property of *obj* to *map*.
 - b. Set the `[[Get]]`, `[[GetOwnProperty]]`, `[[DefineOwnProperty]]`, and `[[Delete]]` internal methods of *obj* to the definitions provided below.
17. If *strict* is **false**, then
 - a. Call the `[[DefineOwnProperty]]` internal method on *obj* passing **"callee"**, the property descriptor `{[[Value]]: func, [[Writable]]: true, [[Enumerable]]: false, [[Configurable]]: true}`, and **false** as arguments.
18. Else, *strict* is **true** so
 - a. Let *thrower* be the `[[ThrowTypeError]]` function Object (13.2.3).
 - b. Call the `[[DefineOwnProperty]]` internal method of *obj* with arguments **"caller"**, PropertyDescriptor `{[[Get]]: thrower, [[Set]]: thrower, [[Enumerable]]: false, [[Configurable]]: false}`, and **false**.
 - c. Call the `[[DefineOwnProperty]]` internal method of *obj* with arguments **"callee"**, PropertyDescriptor `{[[Get]]: thrower, [[Set]]: thrower, [[Enumerable]]: false, [[Configurable]]: false}`, and **false**.
19. Return *obj*

The abstract operation *MakeArgGetter* called with string *name* and environment record *env* creates a function object that when executed returns the value bound for *name* in *env*. It performs the following steps:

1. Let *body* be the result of concatenating the Strings "return ", *name*, and ";"
2. Return the result of creating a function object as described in 13.2 using no *FormalParameterList*, *body* for *FunctionBody*, and *env* as *Scope*.

The abstract operation *MakeArgSetter* called with string *name* and environment record *env* creates a function object that when executed sets the value bound for *name* in *env*. It performs the following steps:

1. Let *param* be the string *name* concatenated with the String "_arg"
2. Let *body* be the String "<name> = <param>;" with <name> replaced by the value of *name* and <param> replaced by the value of *param*.
3. Return the result of creating a function object as described in 13.2 using a List containing the single string *param* as *FormalParameterList*, *body* for *FunctionBody*, and *env* as *Scope*.

The **toString** method of an arguments object performs the following steps when called with a this value *O* and an argument list *L*:

1. Let *toString* be the result of calling the `[[Get]]` internal method of the standard built-in object **Object.prototype** passing "toString" as the argument.
2. If `IsCallable(toString)` is **false**, throw a **TypeError** exception.
3. Return the result of calling the `[[Call]]` internal method of *toString* passing *O* as the **this** value and *L* as the arguments list.

The **toLocaleString** method of an arguments object performs the following steps when called with a this value *O* and an argument list *L*:

1. Let *toLocaleString* be the result of calling the `[[Get]]` internal method of the standard built-in object **Object.prototype** passing "toLocaleString" as the argument.
2. If `IsCallable(toLocaleString)` is **false**, throw a **TypeError** exception.
3. Return the result of calling the `[[Call]]` internal method of *toLocaleString* passing *O* as the **this** value and *L* as the arguments list.

NOTE

These definitions of **toString** and **toLocaleString** exist to provide compatibility with Edition 3 where argument objects inherit from **Object.prototype** instead of **Array.prototype**.

The `[[Get]]` internal method of an arguments object for a function with formal parameters when called with a property name *P* performs the following steps:

1. Let *map* be the value of the `[[ParameterMap]]` internal property of the arguments object.
2. Let *isMapped* be the result of calling the `[[GetOwnProperty]]` internal method of *map* passing *P* as the argument.
3. If the value of *isMapped* is **undefined**, then
 - a. Let *v* be the result of calling the default `[[Get]]` internal method (8.12.3) on the arguments object passing *P* as the argument.
 - b. If *P* is "caller" and *v* is a strict mode Function object, throw a **TypeError** exception.
 - c. Return *v*.
4. Else, *map* contains a formal parameter mapping for *P* so,
 - a. Return the result of calling the `[[Get]]` internal method of *map* passing *P* as the argument.

The `[[GetOwnProperty]]` internal method of an arguments object for a function with formal parameters when called with a property name *P* performs the following steps:

1. Let *desc* be the result of calling the default `[[GetOwnProperty]]` internal method (8.12.1) on the arguments object passing *P* as the argument.
2. If *desc* is **undefined** then return *desc*.
3. Let *map* be the value of the `[[ParameterMap]]` internal property of the arguments object.
4. Let *isMapped* be the result of calling the `[[GetOwnProperty]]` internal method of *map* passing *P* as the argument.
5. If the value of *isMapped* is not **undefined**, then

- a. Set *desc*.[[Value]] to the result of calling the [[Get]] internal method of *map* passing *P* as the argument.
6. Return *desc*.

The [[DefineOwnProperty]] internal method of an arguments object for a function with formal parameters when called with a property name *P*, Property Descriptor *Desc*, and boolean flag *Throw* performs the following steps:

1. Let *map* be the value of the [[ParameterMap]] internal property of the arguments object.
2. Let *isMapped* be the result of calling the [[GetOwnProperty]] internal method of *map* passing *P* as the argument.
3. Let *allowed* be the result of calling the default [[DefineOwnProperty]] internal method (8.12.9) on the arguments object passing *P*, *Desc*, and **false** as the arguments.
4. If *allowed* is **false**, then
 - a. If *Throw* is **true** then throw a **TypeError** exception, otherwise return **false**.
5. If the value of *isMapped* is not **undefined**, then
 - a. If IsAccessorDescriptor(*Desc*) is **true**, then
 - i. Call the [[Delete]] internal method of *map* passing *P*, and **false** as the arguments.
 - b. Else
 - i. If *Desc*.[[Value]] is present, then
 1. Call the [[Put]] internal method of *map* passing *P*, *Desc*.[[Value]], and *Throw* as the arguments.
 - ii. If *Desc*.[[Writable]] is present and its value is **false**, then
 1. Call the [[Delete]] internal method of *map* passing *P* and **false** as arguments.
6. Return **true**.

The [[Delete]] internal method of an arguments object for a function with formal parameters when called with a property name *P* and Boolean flag *Throw* performs the following steps:

1. Let *map* be the value of the [[ParameterMap]] internal property of the arguments object.
2. Let *isMapped* be the result of calling the [[GetOwnProperty]] internal method of *map* passing *P* as the argument.
3. Let *result* be the result of calling the default [[Delete]] internal method (8.12.7) on the arguments object passing *P* and *Throw* as the arguments.
4. If *result* is **true** and the value of *isMapped* is not **undefined**, then
 - a. Call the [[Delete]] internal method of *map* passing *P*, and **false** as the arguments.
5. Return *result*.

NOTE

Array index (15.4) named data properties of an arguments object whose numeric name values are less than the number of formal parameters of the corresponding function object initially share their values with the corresponding argument bindings in the function's execution context. This means that changing the property changes the corresponding value of the argument binding and vice-versa. This correspondence is broken if such a property is deleted and then redefined or if the property is changed into an accessor property.

The ParameterMap object and its property values are used as a device for specifying the arguments object correspondence to argument bindings. The ParameterMap object and the objects that are the values of its properties are not directly accessible from ECMAScript code. An ECMAScript implementation does not need to actually create or use such objects to implement the specified semantics.

Arguments objects for strict mode functions define non-configurable accessor properties named "caller" and "callee" which throw a TypeError exception on access. The "callee" property has a more specific meaning for non-strict mode functions and a "caller" property has historically been provided as an implementation-defined extension by some ECMAScript implementations. The strict mode definition of these properties exists to ensure that neither of them is defined in any other manner by conforming ECMAScript implementations.

11 Expressions

11.1 Primary Expressions

Syntax

PrimaryExpression :

this
Identifier
Literal
ArrayLiteral
ObjectLiteral
(*Expression*)

11.1.1 The **this** Keyword

The **this** keyword evaluates to the value of the *ThisBinding* of the current execution context.

11.1.2 Identifier Reference

An *Identifier* is evaluated by performing Identifier Resolution as stated in 10.3.1. The result of evaluating an *Identifier* is always a value of type Reference.

11.1.3 Literal Reference

A *Literal* is evaluated as described in 7.8.

11.1.4 Array Initialiser

An array initialiser is an expression describing the initialisation of an Array object, written in a form of a literal. It is a list of zero or more expressions, each of which represents an array element, enclosed in square brackets. The elements need not be literals; they are evaluated each time the array initialiser is evaluated.

Array elements may be elided at the beginning, middle or end of the element list. Whenever a comma in the element list is not preceded by an *AssignmentExpression* (i.e., a comma at the beginning or after another comma), the missing array element contributes to the length of the Array and increases the index of subsequent elements. Elided array elements are not defined. If an element is elided at the end of an array, that element does not contribute to the length of the Array.

Syntax

ArrayLiteral :

[*Elision_{opt}*]
[*ElementList*]
[*ElementList* , *Elision_{opt}*]

ElementList :

Elision_{opt} *AssignmentExpression*
ElementList , *Elision_{opt}* *AssignmentExpression*

Elision :

,
Elision ,

Semantics

The production *ArrayLiteral* : [*Elision_{opt}*] is evaluated as follows:

1. Let *array* be the result of creating a new object as if by the expression **new Array()** where **Array** is the standard built-in constructor with that name.
2. Let *pad* be the result of evaluating *Elision*; if not present, use the numeric value zero.
3. Call the *[[Put]]* internal method of *array* with arguments "**length**", *pad*, and **false**.
4. Return *array*.

The production *ArrayLiteral* : [*ElementList*] is evaluated as follows:

1. Return the result of evaluating *ElementList*.

The production *ArrayLiteral* : [*ElementList* , *Elision_{opt}*] is evaluated as follows:

1. Let *array* be the result of evaluating *ElementList*.
2. Let *pad* be the result of evaluating *Elision*; if not present, use the numeric value zero.
3. Let *len* be the result of calling the `[[Get]]` internal method of *array* with argument "**length**".
4. Call the `[[Put]]` internal method of *array* with arguments "**length**", `ToUint32(pad+len)`, and **false**.
5. Return *array*.

The production *ElementList* : *Elision_{opt}* *AssignmentExpression* is evaluated as follows:

1. Let *array* be the result of creating a new object as if by the expression **new Array()** where **Array** is the standard built-in constructor with that name.
2. Let *firstIndex* be the result of evaluating *Elision*; if not present, use the numeric value zero.
3. Let *initResult* be the result of evaluating *AssignmentExpression*.
4. Let *initValue* be `GetValue(initResult)`.
5. Call the `[[DefineOwnProperty]]` internal method of *array* with arguments `Tostring(firstIndex)`, the Property Descriptor { `[[Value]]: initValue`, `[[Writable]]: true`, `[[Enumerable]]: true`, `[[Configurable]]: true`}, and **false**.
6. Return *array*.

The production *ElementList* : *ElementList* , *Elision_{opt}* *AssignmentExpression* is evaluated as follows:

1. Let *array* be the result of evaluating *ElementList*.
2. Let *pad* be the result of evaluating *Elision*; if not present, use the numeric value zero.
3. Let *initResult* be the result of evaluating *AssignmentExpression*.
4. Let *initValue* be `GetValue(initResult)`.
5. Let *len* be the result of calling the `[[Get]]` internal method of *array* with argument "**length**".
6. Call the `[[DefineOwnProperty]]` internal method of *array* with arguments `Tostring(ToUint32((pad+len)))` and the Property Descriptor { `[[Value]]: initValue`, `[[Writable]]: true`, `[[Enumerable]]: true`, `[[Configurable]]: true`}, and **false**.
7. Return *array*.

The production *Elision* : , is evaluated as follows:

1. Return the numeric value 1.

The production *Elision* : *Elision* , is evaluated as follows:

1. Let *preceding* be the result of evaluating *Elision*.
2. Return (*preceding*+1).

NOTE

`[[DefineOwnProperty]]` is used to ensure that own properties are defined for the array even if the standard built-in Array prototype object has been modified in a manner that would preclude the creation of new own properties using `[[Put]]`.

11.1.5 Object Initialiser

An object initialiser is an expression describing the initialisation of an Object, written in a form resembling a literal. It is a list of zero or more pairs of property names and associated values, enclosed in curly braces. The values need not be literals; they are evaluated each time the object initialiser is evaluated.

Syntax

ObjectLiteral :

```
{ }  
{ PropertyNameAndValueList }  
{ PropertyNameAndValueList , }
```

PropertyNameAndValueList :
 PropertyAssignment
 PropertyNameAndValueList , *PropertyAssignment*

PropertyAssignment :
 PropertyName : *AssignmentExpression*
 get *PropertyName* () { *FunctionBody* }
 set *PropertyName* (*PropertySetParameterList*) { *FunctionBody* }

PropertyName :
 IdentifierName
 StringLiteral
 NumericLiteral

PropertySetParameterList :
 Identifier

Semantics

The production *ObjectLiteral* : { } is evaluated as follows:

1. Return a new object created as if by the expression **new Object()** where **Object** is the standard built-in constructor with that name.

The productions *ObjectLiteral* : { *PropertyNameAndValueList* } and
ObjectLiteral : { *PropertyNameAndValueList* , } are evaluated as follows:

1. Return the result of evaluating *PropertyNameAndValueList*.

The production
 PropertyNameAndValueList : *PropertyAssignment*
is evaluated as follows:

1. Let *obj* be the result of creating a new object as if by the expression **new Object()** where **Object** is the standard built-in constructor with that name.
2. Let *propId* be the result of evaluating *PropertyAssignment*.
3. Call the `[[DefineOwnProperty]]` internal method of *obj* with arguments *propId.name*, *propId.descriptor*, and **false**.
4. Return *obj*.

The production
 PropertyNameAndValueList : *PropertyNameAndValueList* , *PropertyAssignment*
is evaluated as follows:

1. Let *obj* be the result of evaluating *PropertyNameAndValueList*.
2. Let *propId* be the result of evaluating *PropertyAssignment*.
3. Let *previous* be the result of calling the `[[GetOwnProperty]]` internal method of *obj* with argument *propId.name*.
4. If *previous* is not **undefined** then throw a **SyntaxError** exception if any of the following conditions are true
 - a. This production is contained in strict code and `IsDataDescriptor(previous)` is **true** and `IsDataDescriptor(propId.descriptor)` is **true**.
 - b. `IsDataDescriptor(previous)` is **true** and `IsAccessorDescriptor(propId.descriptor)` is **true**.
 - c. `IsAccessorDescriptor(previous)` is **true** and `IsDataDescriptor(propId.descriptor)` is **true**.
 - d. `IsAccessorDescriptor(previous)` is **true** and `IsAccessorDescriptor(propId.descriptor)` is **true** and either both *previous* and *propId.descriptor* have `[[Get]]` fields or both *previous* and *propId.descriptor* have `[[Set]]` fields
5. Call the `[[DefineOwnProperty]]` internal method of *obj* with arguments *propId.name*, *propId.descriptor*, and **false**.
6. Return *obj*.

If the above steps would throw a `SyntaxError` then an implementation must treat the error as an early error (Section 16).

The production `PropertyAssignment : PropertyName : AssignmentExpression` is evaluated as follows:

1. Let *propName* be the result of evaluating *PropertyName*.
2. Let *exprValue* be the result of evaluating *AssignmentExpression*.
3. Let *propValue* be `GetValue(exprValue)`.
4. Let *desc* be the Property Descriptor{[[Value]]: *propValue*, [[Writable]]: **true**, [[Enumerable]]: **true**, [[Configurable]]: **true**}
5. Return Property Identifier (*propName*, *desc*).

The production `PropertyAssignment : get PropertyName () { FunctionBody }` is evaluated as follows:

1. Let *propName* be the result of evaluating *PropertyName*.
2. Let *closure* be the result of creating a new Function object as specified in 13.2 with an empty parameter list and body specified by *FunctionBody*. Pass in the `LexicalEnvironment` of the running execution context as the *Scope*.
3. Let *desc* be the Property Descriptor{[[Get]]: *closure*, [[Enumerable]]: **true**, [[Configurable]]: **true**}
4. Return Property Identifier (*propName*, *desc*).

The production `PropertyAssignment : set PropertyName (PropertySetParameterList) { FunctionBody }` is evaluated as follows:

1. Let *propName* be the result of evaluating *PropertyName*.
2. Let *closure* be the result of creating a new Function object as specified in 13.2 with parameters specified by *PropertySetParameterList* and body specified by *FunctionBody*. Pass in the `LexicalEnvironment` of the running execution context as the *Scope*.
3. Let *desc* be the Property Descriptor{[[Set]]: *closure*, [[Enumerable]]: **true**, [[Configurable]]: **true**}
4. Return Property Identifier (*propName*, *desc*).

The production `PropertyName : IdentifierName` is evaluated as follows:

1. Return the string value containing the same sequence of characters as the *IdentifierName*.

The production `PropertyName : StringLiteral` is evaluated as follows:

1. Return the value of the *StringLiteral*.

The production `PropertyName : NumericLiteral` is evaluated as follows:

1. Let *nbr* be the result of forming the value of the *NumericLiteral*.
2. Return `ToString(nbr)`.

11.1.6 The Grouping Operator

The production `PrimaryExpression : (Expression)` is evaluated as follows:

1. Return the result of evaluating *Expression*. This may be of type `Reference`.

NOTE

*This algorithm does not apply `GetValue` to the result of evaluating *Expression*. The principal motivation for this is so that operators such as **delete** and **typeof** may be applied to parenthesised expressions.*

11.2 Left-Hand-Side Expressions

Syntax

MemberExpression :

PrimaryExpression
FunctionExpression
MemberExpression [*Expression*]
MemberExpression . *IdentifierName*
new *MemberExpression* *Arguments*

NewExpression :

MemberExpression
new *NewExpression*

CallExpression :

MemberExpression *Arguments*
CallExpression *Arguments*
CallExpression [*Expression*]
CallExpression . *IdentifierName*

Arguments :

()
(*ArgumentList*)

ArgumentList :

AssignmentExpression
ArgumentList , *AssignmentExpression*

LeftHandSideExpression :

NewExpression
CallExpression

11.2.1 Property Accessors

Properties are accessed by name, using either the dot notation:

MemberExpression . *IdentifierName*
CallExpression . *IdentifierName*

or the bracket notation:

MemberExpression [*Expression*]
CallExpression [*Expression*]

The dot notation is explained by the following syntactic conversion:

MemberExpression . *IdentifierName*

is identical in its behaviour to

MemberExpression [<*identifier-name-string*>]

and similarly

CallExpression . *IdentifierName*

is identical in its behaviour to

CallExpression [<identifier-name-string>]

where <identifier-name-string> is a string literal containing the same sequence of characters after processing of Unicode escape sequences as the *IdentifierName*.

The production *MemberExpression* : *MemberExpression* [*Expression*] is evaluated as follows:

1. Let *baseReference* be the result of evaluating *MemberExpression*.
2. Let *baseValue* be *GetValue(baseReference)*.
3. Let *propertyNameReference* be the result of evaluating *Expression*.
4. Let *propertyNameValue* be *GetValue(propertyNameReference)*.
5. Call *CheckObjectCoercible(baseValue)*.
6. Let *propertyNameString* be *ToString(propertyNameValue)*.
7. If the syntactic production that is being evaluated is contained in strict mode code, let *strict* be **true**, else let *strict* be **false**.
8. Return a value of type *Reference* whose base value is *baseValue* and whose referenced name is *propertyNameString*, and whose strict mode flag is *strict*.

The production *CallExpression* : *CallExpression* [*Expression*] is evaluated in exactly the same manner, except that the contained *CallExpression* is evaluated in step 1.

11.2.2 The new Operator

The production *NewExpression* : **new** *NewExpression* is evaluated as follows:

1. Let *ref* be the result of evaluating *NewExpression*.
2. Let *constructor* be *GetValue(ref)*.
3. If *Type(constructor)* is not *Object*, throw a **TypeError** exception.
4. If *constructor* does not implement the *[[Construct]]* internal method, throw a **TypeError** exception.
5. Return the result of calling the *[[Construct]]* internal method on *constructor*, providing no arguments (that is, an empty list of arguments).

The production *MemberExpression* : **new** *MemberExpression Arguments* is evaluated as follows:

1. Let *ref* be the result of evaluating *MemberExpression*.
2. Let *constructor* be *GetValue(ref)*.
3. Let *argList* be the result of evaluating *Arguments*, producing an internal list of argument values (11.2.4).
4. If *Type(constructor)* is not *Object*, throw a **TypeError** exception.
5. If *constructor* does not implement the *[[Construct]]* internal method, throw a **TypeError** exception.
6. Return the result of calling the *[[Construct]]* internal method on *constructor*, providing the list *argList* as the argument values.

11.2.3 Function Calls

The production *CallExpression* : *MemberExpression Arguments* is evaluated as follows:

1. Let *ref* be the result of evaluating *MemberExpression*.
2. Let *func* be *GetValue(ref)*.
3. Let *argList* be the result of evaluating *Arguments*, producing an internal list of argument values (see 11.2.4).
4. If *Type(func)* is not *Object*, throw a **TypeError** exception.
5. If *IsCallable(func)* is **false**, throw a **TypeError** exception.
6. If *Type(ref)* is *Reference*, then
 - a. If *IsPropertyReference(ref)* is **true**, then
 - i. Let *thisValue* be *GetBase(ref)*.
 - b. Else, the base of *ref* is an *Environment Record*
 - i. Let *thisValue* be the result of calling the *ImplicitThisValue* concrete method of *GetBase(ref)*.
7. Else, *Type(ref)* is not *Reference*.
 - a. Let *thisValue* be **undefined**.
8. Return the result of calling the *[[Call]]* internal method on *func*, providing *thisValue* as the **this** value and providing the list *argList* as the argument values.

The production *CallExpression* : *CallExpression Arguments* is evaluated in exactly the same manner, except that the contained *CallExpression* is evaluated in step 1.

NOTE

The returned result will never be of type Reference if *func* is a native ECMAScript object. Whether calling a host object can return a value of type Reference is implementation-dependent. If a value of type Reference is returned, it must be a non-strict Property Reference.

11.2.4 Argument Lists

The evaluation of an argument list produces a List of values (see 8.8).

The production *Arguments* : () is evaluated as follows:

1. Return an empty List.

The production *Arguments* : (*ArgumentList*) is evaluated as follows:

1. Return the result of evaluating *ArgumentList*.

The production *ArgumentList* : *AssignmentExpression* is evaluated as follows:

1. Let *ref* be the result of evaluating *AssignmentExpression*.
2. Let *arg* be GetValue(*ref*).
3. Return a List whose sole item is *arg*.

The production *ArgumentList* : *ArgumentList* , *AssignmentExpression* is evaluated as follows:

1. Let *precedingArgs* be the result of evaluating *ArgumentList*.
2. Let *ref* be the result of evaluating *AssignmentExpression*.
3. Let *arg* be GetValue(*ref*).
4. Return a List whose length is one greater than the length of *precedingArgs* and whose items are the items of *precedingArgs*, in order, followed at the end by *arg* which is the last item of the new list.

11.2.5 Function Expressions

The production *MemberExpression* : *FunctionExpression* is evaluated as follows:

1. Return the result of evaluating *FunctionExpression*.

11.3 Postfix Expressions

Syntax

PostfixExpression :

LeftHandSideExpression

LeftHandSideExpression [no *LineTerminator* here] ++

LeftHandSideExpression [no *LineTerminator* here] --

11.3.1 Postfix Increment Operator

The production *PostfixExpression* : *LeftHandSideExpression* [no *LineTerminator* here] ++ is evaluated as follows:

1. Let *lhs* be the result of evaluating *LeftHandSideExpression*.
2. Throw a **SyntaxError** exception if the following conditions are all true:
 - Type(*lhs*) is Reference is **true**
 - IsStrictReference(*lhs*) is **true**
 - Type(GetBase(*lhs*)) is Environment Record
 - GetReferencedName(*lhs*) is "eval"
3. Let *oldValue* be ToNumber(GetValue(*lhs*)).
4. Let *newValue* be the result of adding the value 1 to *oldValue*, using the same rules as for the + operator (see 11.6.3).
5. Call PutValue(*lhs*, *newValue*).
6. Return *oldValue*.

11.3.2 Postfix Decrement Operator

The production *PostfixExpression* : *LeftHandSideExpression* [no *LineTerminator* here] **--** is evaluated as follows:

1. Let *lhs* be the result of evaluating *LeftHandSideExpression*.
2. Throw a **SyntaxError** exception if the following conditions are all true:
 - `Type(lhs)` is Reference is **true**
 - `IsStrictReference(lhs)` is **true**
 - `Type(GetBase(lhs))` is Environment Record
 - `GetReferencedName(lhs)` is **"eval"**
3. Let *oldValue* be `ToNumber(GetValue(lhs))`.
4. Let *newValue* be the result of subtracting the value **1** from *oldValue*, using the same rules as for the **-** operator (11.6.3).
5. Call `PutValue(lhs, newValue)`.
6. Return *oldValue*.

11.4 Unary Operators

Syntax

UnaryExpression :

PostfixExpression
delete *UnaryExpression*
void *UnaryExpression*
typeof *UnaryExpression*
++ *UnaryExpression*
-- *UnaryExpression*
+ *UnaryExpression*
- *UnaryExpression*
~ *UnaryExpression*
! *UnaryExpression*

11.4.1 The delete Operator

The production *UnaryExpression* : **delete** *UnaryExpression* is evaluated as follows:

1. Let *ref* be the result of evaluating *UnaryExpression*.
2. If `Type(ref)` is not Reference, return **true**.
3. If `IsUnresolvableReference(ref)` return **true**.
4. If `IsPropertyReference(ref)` is **true**, then
 - a. Return the result of calling the `[[Delete]]` internal method on `ToObject(GetBase(ref))` providing `GetReferencedName(ref)` and `IsStrictReference(ref)` as the arguments.
5. Else, *ref* is a Reference to an Environment Record binding, so
 - a. If `IsStrictReference(ref)` is **true** throw a **SyntaxError** exception.
 - b. Let *bindings* be `GetBase(ref)`.
 - c. Return the result of calling the `DeleteBinding` concrete method of *bindings*, providing `GetReferencedName(ref)` as the argument.

NOTE

When a **delete** operator occurs within strict mode code, a **SyntaxError** exception is thrown if its *UnaryExpression* is a direct reference to a variable, function argument, or function name. In addition, if a **delete** operator occurs within strict mode code and the property to be deleted has the attribute `[[Configurable]]: false`, a **TypeError** exception is thrown.

11.4.2 The void Operator

The production *UnaryExpression* : **void** *UnaryExpression* is evaluated as follows:

1. Let *expr* be the result of evaluating *UnaryExpression*.
2. Call `GetValue(expr)`.
3. Return **undefined**.

NOTE

GetValue must be called even though its value is not used because it may have observable side-effects.

11.4.3 The typeof Operator

The production *UnaryExpression* : **typeof** *UnaryExpression* is evaluated as follows:

1. Let *val* be the result of evaluating *UnaryExpression*.
2. If *Type(val)* is Reference, then
 - a. If *IsUnresolvableReference(val)* is **true**, return **"undefined"**.
 - b. Let *val* be *GetValue(val)*.
3. Return a string determined by *Type(val)* according to the following table:

| <i>Type</i> | <i>Result</i> |
|---|---|
| Undefined | "undefined" |
| Null | "object" |
| Boolean | "boolean" |
| Number | "number" |
| String | "string" |
| Object (native and doesn't implement <i>[[Call]]</i>) | "object" |
| Object (native or host and implements <i>[[Call]]</i>) | "function" |
| Object (host and doesn't implement <i>[[Call]]</i>) | Implementation-defined except may not be "undefined" , "boolean" , "number" , or "string" . |

11.4.4 Prefix Increment Operator

The production *UnaryExpression* : **++** *UnaryExpression* is evaluated as follows:

1. Let *expr* be the result of evaluating *UnaryExpression*.
2. Throw a **SyntaxError** exception if the following conditions are all true:
 - *Type(expr)* is Reference is **true**
 - *IsStrictReference(expr)* is **true**
 - *Type(GetBase(expr))* is Environment Record
 - *GetReferencedName(expr)* is **"eval"**
3. Let *oldValue* be *ToNumber(GetValue(expr))*.
4. Let *newValue* be the result of adding the value **1** to *oldValue*, using the same rules as for the **+** operator (see 11.6.3).
5. Call *PutValue(expr, newValue)*.
6. Return *newValue*.

11.4.5 Prefix Decrement Operator

The production *UnaryExpression* : **--** *UnaryExpression* is evaluated as follows:

1. Let *expr* be the result of evaluating *UnaryExpression*.
2. Throw a **SyntaxError** exception if the following conditions are all true:
 - *Type(expr)* is Reference is **true**
 - *IsStrictReference(expr)* is **true**
 - *Type(GetBase(expr))* is Environment Record
 - *GetReferencedName(expr)* is **"eval"**
3. Let *oldValue* be *ToNumber(GetValue(expr))*.
4. Let *newValue* be the result of subtracting the value **1** from *oldValue*, using the same rules as for the **-** operator (see 11.6.3).

5. Call `PutValue(expr, newValue)`.
6. Return `newValue`.

11.4.6 Unary + Operator

The unary `+` operator converts its operand to Number type.

The production `UnaryExpression : + UnaryExpression` is evaluated as follows:

1. Let `expr` be the result of evaluating `UnaryExpression`.
2. Return `ToNumber(GetValue(expr))`.

11.4.7 Unary - Operator

The unary `-` operator converts its operand to Number type and then negates it. Note that negating `+0` produces `-0`, and negating `-0` produces `+0`.

The production `UnaryExpression : - UnaryExpression` is evaluated as follows:

1. Let `expr` be the result of evaluating `UnaryExpression`.
2. Let `oldValue` be `ToNumber(GetValue(expr))`.
3. If `oldValue` is `NaN`, return `NaN`.
4. Return the result of negating `oldValue`; that is, compute a number with the same magnitude but opposite sign.

11.4.8 Bitwise NOT Operator (~)

The production `UnaryExpression : ~ UnaryExpression` is evaluated as follows:

1. Let `expr` be the result of evaluating `UnaryExpression`.
2. Let `oldValue` be `ToInt32(GetValue(expr))`.
3. Return the result of applying bitwise complement to `oldValue`. The result is a signed 32-bit integer.

11.4.9 Logical NOT Operator (!)

The production `UnaryExpression : ! UnaryExpression` is evaluated as follows:

1. Let `expr` be the result of evaluating `UnaryExpression`.
2. Let `oldValue` be `ToBoolean(GetValue(expr))`.
3. If `oldValue` is `true`, return `false`.
4. Return `true`.

11.5 Multiplicative Operators

Syntax

MultiplicativeExpression :

UnaryExpression

MultiplicativeExpression * *UnaryExpression*

MultiplicativeExpression / *UnaryExpression*

MultiplicativeExpression % *UnaryExpression*

Semantics

The production `MultiplicativeExpression : MultiplicativeExpression @ UnaryExpression`, where `@` stands for one of the operators in the above definitions, is evaluated as follows:

1. Let `left` be the result of evaluating `MultiplicativeExpression`.
2. Let `leftValue` be `GetValue(left)`.
3. Let `right` be the result of evaluating `UnaryExpression`.
4. Let `rightValue` be `GetValue(right)`.
5. Let `leftNum` be `ToNumber(leftValue)`.
6. Let `rightNum` be `ToNumber(rightValue)`.
7. Return the result of applying the specified operation (`*`, `/`, or `%`) to `leftNum` and `rightNum`. See the notes below (11.5.1, 11.5.2, 11.5.3).

11.5.1 Applying the * Operator

The * operator performs multiplication, producing the product of its operands. Multiplication is commutative. Multiplication is not always associative in ECMAScript, because of finite precision.

The result of a floating-point multiplication is governed by the rules of IEEE 754 binary double-precision arithmetic:

- If either operand is **NaN**, the result is **NaN**.
- The sign of the result is positive if both operands have the same sign, negative if the operands have different signs.
- Multiplication of an infinity by a zero results in **NaN**.
- Multiplication of an infinity by an infinity results in an infinity. The sign is determined by the rule already stated above.
- Multiplication of an infinity by a finite non-zero value results in a signed infinity. The sign is determined by the rule already stated above.
- In the remaining cases, where neither an infinity or NaN is involved, the product is computed and rounded to the nearest representable value using IEEE 754 round-to-nearest mode. If the magnitude is too large to represent, the result is then an infinity of appropriate sign. If the magnitude is too small to represent, the result is then a zero of appropriate sign. The ECMAScript language requires support of gradual underflow as defined by IEEE 754.

11.5.2 Applying the / Operator

The / operator performs division, producing the quotient of its operands. The left operand is the dividend and the right operand is the divisor. ECMAScript does not perform integer division. The operands and result of all division operations are double-precision floating-point numbers. The result of division is determined by the specification of IEEE 754 arithmetic:

- If either operand is **NaN**, the result is **NaN**.
- The sign of the result is positive if both operands have the same sign, negative if the operands have different signs.
- Division of an infinity by an infinity results in **NaN**.
- Division of an infinity by a zero results in an infinity. The sign is determined by the rule already stated above.
- Division of an infinity by a non-zero finite value results in a signed infinity. The sign is determined by the rule already stated above.
- Division of a finite value by an infinity results in zero. The sign is determined by the rule already stated above.
- Division of a zero by a zero results in **NaN**; division of zero by any other finite value results in zero, with the sign determined by the rule already stated above.
- Division of a non-zero finite value by a zero results in a signed infinity. The sign is determined by the rule already stated above.
- In the remaining cases, where neither an infinity, nor a zero, nor **NaN** is involved, the quotient is computed and rounded to the nearest representable value using IEEE 754 round-to-nearest mode. If the magnitude is too large to represent, the operation overflows; the result is then an infinity of appropriate sign. If the magnitude is too small to represent, the operation underflows and the result is a zero of the appropriate sign. The ECMAScript language requires support of gradual underflow as defined by IEEE 754.

11.5.3 Applying the % Operator

The % operator yields the remainder of its operands from an implied division; the left operand is the dividend and the right operand is the divisor.

NOTE

In C and C++, the remainder operator accepts only integral operands; in ECMAScript, it also accepts floating-point operands.

The result of a floating-point remainder operation as computed by the % operator is not the same as the “remainder” operation defined by IEEE 754. The IEEE 754 “remainder” operation computes the remainder from a rounding division, not a truncating division, and so its behaviour is not analogous to that of the usual integer remainder operator. Instead the ECMAScript language defines % on floating-point operations to behave in a manner analogous to that of the Java integer remainder operator; this may be compared with the C library function fmod.

The result of an ECMAScript floating-point remainder operation is determined by the rules of IEEE arithmetic:

- If either operand is **NaN**, the result is **NaN**.
- The sign of the result equals the sign of the dividend.
- If the dividend is an infinity, or the divisor is a zero, or both, the result is **NaN**.
- If the dividend is finite and the divisor is an infinity, the result equals the dividend.
- If the dividend is a zero and the divisor is finite, the result is the same as the dividend.
- In the remaining cases, where neither an infinity, nor a zero, nor **NaN** is involved, the floating-point remainder r from a dividend n and a divisor d is defined by the mathematical relation $r = n - (d * q)$ where q is an integer that is negative only if n/d is negative and positive only if n/d is positive, and whose magnitude is as large as possible without exceeding the magnitude of the true mathematical quotient of n and d .

11.6 Additive Operators

Syntax

AdditiveExpression :

MultiplicativeExpression

AdditiveExpression + *MultiplicativeExpression*

AdditiveExpression - *MultiplicativeExpression*

11.6.1 The Addition operator (+)

The addition operator either performs string concatenation or numeric addition.

The production *AdditiveExpression* : *AdditiveExpression* + *MultiplicativeExpression* is evaluated as follows:

1. Let *lref* be the result of evaluating *AdditiveExpression*.
2. Let *lval* be *GetValue(lref)*.
3. Let *rref* be the result of evaluating *MultiplicativeExpression*.
4. Let *rval* be *GetValue(rref)*.
5. Let *lprim* be *ToPrimitive(lval)*.
6. Let *rprim* be *ToPrimitive(rval)*.
7. If *Type(lprim)* is String or *Type(rprim)* is String, then
 - a. Return the String that is the result of concatenating *ToString(lprim)* followed by *ToString(rprim)*
8. Return the result of applying the addition operation to *ToNumber(lprim)* and *ToNumber(rprim)*. See the note below (11.6.3).

NOTE

No hint is provided in the calls to ToPrimitive in steps 5 and 6. All native ECMAScript objects except Date objects handle the absence of a hint as if the hint Number were given; Date objects handle the absence of a hint as if the hint String were given. Host objects may handle the absence of a hint in some other manner.

Step 7 differs from step 3 of the comparison algorithm for the relational operators (11.8.5), by using or instead of and.

11.6.2 The Subtraction Operator (-)

The production *AdditiveExpression* : *AdditiveExpression* - *MultiplicativeExpression* is evaluated as follows:

1. Let *lref* be the result of evaluating *AdditiveExpression*.
2. Let *lval* be *GetValue(lref)*.
3. Let *rref* be the result of evaluating *MultiplicativeExpression*.
4. Let *rval* be *GetValue(rref)*.
5. Let *lnum* be *ToNumber(lval)*.
6. Let *rnum* be *ToNumber(rval)*.
7. Return the result of applying the subtraction operation to *lnum* and *rnum*. See the note below (11.6.3).

11.6.3 Applying the Additive Operators (+ , -) to Numbers

The + operator performs addition when applied to two operands of numeric type, producing the sum of the operands. The - operator performs subtraction, producing the difference of two numeric operands.

Addition is a commutative operation, but not always associative.

The result of an addition is determined using the rules of IEEE 754 binary double-precision arithmetic:

- If either operand is **NaN**, the result is **NaN**.
- The sum of two infinities of opposite sign is **NaN**.
- The sum of two infinities of the same sign is the infinity of that sign.
- The sum of an infinity and a finite value is equal to the infinite operand.
- The sum of two negative zeros is **-0**. The sum of two positive zeros, or of two zeros of opposite sign, is **+0**.
- The sum of a zero and a nonzero finite value is equal to the nonzero operand.
- The sum of two nonzero finite values of the same magnitude and opposite sign is **+0**.
- In the remaining cases, where neither an infinity, nor a zero, nor NaN is involved, and the operands have the same sign or have different magnitudes, the sum is computed and rounded to the nearest representable value using IEEE 754 round-to-nearest mode. If the magnitude is too large to represent, the operation overflows and the result is then an infinity of appropriate sign. The ECMAScript language requires support of gradual underflow as defined by IEEE 754.

The - operator performs subtraction when applied to two operands of numeric type, producing the difference of its operands; the left operand is the minuend and the right operand is the subtrahend. Given numeric operands *a* and *b*, it is always the case that *a-b* produces the same result as *a+(-b)*.

11.7 Bitwise Shift Operators

Syntax

ShiftExpression :

AdditiveExpression

ShiftExpression << *AdditiveExpression*

ShiftExpression >> *AdditiveExpression*

ShiftExpression >>> *AdditiveExpression*

11.7.1 The Left Shift Operator (<<)

Performs a bitwise left shift operation on the left operand by the amount specified by the right operand.

The production *ShiftExpression* : *ShiftExpression* << *AdditiveExpression* is evaluated as follows:

1. Let *lref* be the result of evaluating *ShiftExpression*.
2. Let *lval* be *GetValue(lref)*.
3. Let *rref* be the result of evaluating *AdditiveExpression*.
4. Let *rval* be *GetValue(rref)*.
5. Let *lnum* be *ToInt32(lval)*.
6. Let *rnum* be *ToUint32(rval)*.
7. Let *shiftCount* be the result of masking out all but the least significant 5 bits of *rnum*, that is, compute *rnum* & 0x1F.
8. Return the result of left shifting *lnum* by *shiftCount* bits. The result is a signed 32 bit integer.

11.7.2 The Signed Right Shift Operator (>>)

Performs a sign-filling bitwise right shift operation on the left operand by the amount specified by the right operand.

The production *ShiftExpression* : *ShiftExpression* >> *AdditiveExpression* is evaluated as follows:

1. Let *lref* be the result of evaluating *ShiftExpression*.
2. Let *lval* be GetValue(*lref*).
3. Let *rref* be the result of evaluating *AdditiveExpression*.
4. Let *rval* be GetValue(*rref*).
5. Let *lnum* be ToInt32(*lval*).
6. Let *rnum* be ToUInt32(*rval*).
7. Let *shiftCount* be the result of masking out all but the least significant 5 bits of *rnum*, that is, compute *rnum* & 0x1F.
8. Return the result of performing a sign-extending right shift of *lnum* by *shiftCount* bits. The most significant bit is propagated. The result is a signed 32 bit integer.

11.7.3 The Unsigned Right Shift Operator (>>>)

Performs a zero-filling bitwise right shift operation on the left operand by the amount specified by the right operand.

The production *ShiftExpression* : *ShiftExpression* >>> *AdditiveExpression* is evaluated as follows:

1. Let *lref* be the result of evaluating *ShiftExpression*.
2. Let *lval* be GetValue(*lref*).
3. Let *rref* be the result of evaluating *AdditiveExpression*.
4. Let *rval* be GetValue(*rref*).
5. Let *lnum* be ToUInt32(*lval*).
6. Let *rnum* be ToUInt32(*rval*).
7. Let *shiftCount* be the result of masking out all but the least significant 5 bits of *rnum*, that is, compute *rnum* & 0x1F.
8. Return the result of performing a zero-filling right shift of *lnum* by *shiftCount* bits. Vacated bits are filled with zero. The result is an unsigned 32 bit integer.

11.8 Relational Operators

Syntax

RelationalExpression :

ShiftExpression
RelationalExpression < *ShiftExpression*
RelationalExpression > *ShiftExpression*
RelationalExpression <= *ShiftExpression*
RelationalExpression >= *ShiftExpression*
RelationalExpression **instanceof** *ShiftExpression*
RelationalExpression **in** *ShiftExpression*

RelationalExpressionNoIn :

ShiftExpression
RelationalExpressionNoIn < *ShiftExpression*
RelationalExpressionNoIn > *ShiftExpression*
RelationalExpressionNoIn <= *ShiftExpression*
RelationalExpressionNoIn >= *ShiftExpression*
RelationalExpressionNoIn **instanceof** *ShiftExpression*

NOTE

The “NoIn” variants are needed to avoid confusing the *in* operator in a relational expression with the *in* operator in a *for* statement.

Semantics

The result of evaluating a relational operator is always of type Boolean, reflecting whether the relationship named by the operator holds between its two operands.

The *RelationalExpressionNoIn* productions are evaluated in the same manner as the *RelationalExpression* productions except that the contained *RelationalExpressionNoIn* is evaluated instead of the contained *RelationalExpression*.

11.8.1 The Less-than Operator (<)

The production *RelationalExpression* : *RelationalExpression* < *ShiftExpression* is evaluated as follows:

1. Let *lref* be the result of evaluating *RelationalExpression*.
2. Let *lval* be *GetValue(lref)*.
3. Let *rref* be the result of evaluating *ShiftExpression*.
4. Let *rval* be *GetValue(rref)*.
5. Let *r* be the result of performing abstract relational comparison *lval* < *rval*. (see 11.8.5)
6. If *r* is **undefined**, return **false**. Otherwise, return *r*.

11.8.2 The Greater-than Operator (>)

The production *RelationalExpression* : *RelationalExpression* > *ShiftExpression* is evaluated as follows:

1. Let *lref* be the result of evaluating *RelationalExpression*.
2. Let *lval* be *GetValue(lref)*.
3. Let *rref* be the result of evaluating *ShiftExpression*.
4. Let *rval* be *GetValue(rref)*.
5. Let *r* be the result of performing abstract relational comparison *rval* < *lval* with *LeftFirst* equal to **false**. (see 11.8.5).
6. If *r* is **undefined**, return **false**. Otherwise, return *r*.

11.8.3 The Less-than-or-equal Operator (<=)

The production *RelationalExpression* : *RelationalExpression* <= *ShiftExpression* is evaluated as follows:

1. Let *lref* be the result of evaluating *RelationalExpression*.
2. Let *lval* be *GetValue(lref)*.
3. Let *rref* be the result of evaluating *ShiftExpression*.
4. Let *rval* be *GetValue(rref)*.
5. Let *r* be the result of performing abstract relational comparison *rval* < *lval* with *LeftFirst* equal to **false**. (see 11.8.5).
6. If *r* is **true** or **undefined**, return **false**. Otherwise, return **true**.

11.8.4 The Greater-than-or-equal Operator (>=)

The production *RelationalExpression* : *RelationalExpression* >= *ShiftExpression* is evaluated as follows:

1. Let *lref* be the result of evaluating *RelationalExpression*.
2. Let *lval* be *GetValue(lref)*.
3. Let *rref* be the result of evaluating *ShiftExpression*.
4. Let *rval* be *GetValue(rref)*.
5. Let *r* be the result of performing abstract relational comparison *lval* < *rval*. (see 11.8.5)
6. If *r* is **true** or **undefined**, return **false**. Otherwise, return **true**.

11.8.5 The Abstract Relational Comparison Algorithm

The comparison $x < y$, where x and y are values, produces **true**, **false**, or **undefined** (which indicates that at least one operand is **NaN**). In addition to x and y the algorithm takes a boolean flag named *LeftFirst* as a parameter. The flag is used to control the order in which operations with potentially visible side-effects are performed upon x and y . It is necessary because ECMAScript specifies left to right evaluation of expressions. The default value of *LeftFirst* is **true** and indicates that the x parameter corresponds to an expression that occurs to the left of the y parameter's corresponding expression. If *LeftFirst* is **false**, the reverse is the case and operations must be performed upon y before x . Such a comparison is performed as follows:

1. If the *LeftFirst* flag is true, then
 - a. Let px be the result of calling `ToPrimitive(x, hint Number)`.
 - b. Let py be the result of calling `ToPrimitive(y, hint Number)`.
2. Else the order of evaluation needs to be reversed to preserve left to right evaluation
 - a. Let py be the result of calling `ToPrimitive(y, hint Number)`.
 - b. Let px be the result of calling `ToPrimitive(x, hint Number)`.
3. If it is not the case that both `Type(px)` is `String` and `Type(py)` is `String`, then
 - a. Let nx be the result of calling `ToNumber(px)`. Because of px and py are primitive values evaluation order is not important.
 - b. Let ny be the result of calling `ToNumber(py)`.
 - c. If nx is **NaN**, return **undefined**.
 - d. If ny is **NaN**, return **undefined**.
 - e. If nx and ny are the same number value, return **false**.
 - f. If nx is **+0** and ny is **-0**, return **false**.
 - g. If nx is **-0** and ny is **+0**, return **false**.
 - h. If nx is **+∞**, return **false**.
 - i. If ny is **+∞**, return **true**.
 - j. If ny is **-∞**, return **false**.
 - k. If nx is **-∞**, return **true**.
 - l. If the mathematical value of nx is less than the mathematical value of ny —note that these mathematical values are both finite and not both zero—return **true**. Otherwise, return **false**.
4. Else, both px and py are `Strings`
 - a. If py is a prefix of px , return **false**. (A string value p is a prefix of string value q if q can be the result of concatenating p and some other string r . Note that any string is a prefix of itself, because r may be the empty string.)
 - b. If px is a prefix of py , return **true**.
 - c. Let k be the smallest nonnegative integer such that the character at position k within px is different from the character at position k within py . (There must be such a k , for neither string is a prefix of the other.)
 - d. Let m be the integer that is the code unit value for the character at position k within px .
 - e. Let n be the integer that is the code unit value for the character at position k within py .
 - f. If $m < n$, return **true**. Otherwise, return **false**.

NOTE

Step 3 differs from step 7 in the algorithm for the addition operator **+** (11.6.1) in using *and* instead of *or*.

The comparison of strings uses a simple lexicographic ordering on sequences of code unit values. There is no attempt to use the more complex, semantically oriented definitions of character or string equality and collating order defined in the Unicode specification. Therefore strings that are canonically equal according to the Unicode standard could test as unequal. In effect this algorithm assumes that both strings are already in normalised form.

11.8.6 The instanceof operator

The production *RelationalExpression*: *RelationalExpression* **instanceof** *ShiftExpression* is evaluated as follows:

1. Let *lref* be the result of evaluating *RelationalExpression*.
2. Let *lval* be `GetValue(lref)`.
3. Let *rref* be the result of evaluating *ShiftExpression*.
4. Let *rval* be `GetValue(rref)`.
5. If `Type(rval)` is not `Object`, throw a **TypeError** exception.
6. If *rval* does not have a `[[HasInstance]]` internal method, throw a **TypeError** exception.
7. Return the result of calling the `[[HasInstance]]` internal method of *rval* with argument *lval*.

11.8.7 The in operator

The production *RelationalExpression* : *RelationalExpression* **in** *ShiftExpression* is evaluated as follows:

1. Let *lref* be the result of evaluating *RelationalExpression*.
2. Let *lval* be `GetValue(lref)`.

3. Let *rref* be the result of evaluating *ShiftExpression*.
4. Let *rval* be `GetValue(rref)`.
5. If `Type(rval)` is not `Object`, throw a **TypeError** exception.
6. Call `ToString(lval)`.
7. Return the result of calling the `[[HasProperty]]` internal method of *rval* with argument `ToString(lval)`.

11.9 Equality Operators

Syntax

EqualityExpression :

RelationalExpression
EqualityExpression **==** *RelationalExpression*
EqualityExpression **!=** *RelationalExpression*
EqualityExpression **===** *RelationalExpression*
EqualityExpression **!==** *RelationalExpression*

EqualityExpressionNoIn :

RelationalExpressionNoIn
EqualityExpressionNoIn **==** *RelationalExpressionNoIn*
EqualityExpressionNoIn **!=** *RelationalExpressionNoIn*
EqualityExpressionNoIn **===** *RelationalExpressionNoIn*
EqualityExpressionNoIn **!==** *RelationalExpressionNoIn*

Semantics

The result of evaluating an equality operator is always of type `Boolean`, reflecting whether the relationship named by the operator holds between its two operands.

The *EqualityExpressionNoIn* productions are evaluated in the same manner as the *EqualityExpression* productions except that the contained *EqualityExpressionNoIn* and *RelationalExpressionNoIn* are evaluated instead of the contained *EqualityExpression* and *RelationalExpression*, respectively.

11.9.1 The Equals Operator (==)

The production *EqualityExpression* : *EqualityExpression* **==** *RelationalExpression* is evaluated as follows:

1. Let *lref* be the result of evaluating *EqualityExpression*.
2. Let *lval* be `GetValue(lref)`.
3. Let *rref* be the result of evaluating *RelationalExpression*.
4. Let *rval* be `GetValue(rref)`.
5. Return the result of performing abstract equality comparison `rval == lval`. (see 11.9.3).

11.9.2 The Does-not-equals Operator (!=)

The production *EqualityExpression* : *EqualityExpression* **!=** *RelationalExpression* is evaluated as follows:

1. Let *lref* be the result of evaluating *EqualityExpression*.
2. Let *lval* be `GetValue(lref)`.
3. Let *rref* be the result of evaluating *RelationalExpression*.
4. Let *rval* be `GetValue(rref)`.
5. Let *r* be the result of performing abstract equality comparison `rval == lval`. (see 11.9.3).
6. If *r* is **true**, return **false**. Otherwise, return **true**.

11.9.3 The Abstract Equality Comparison Algorithm

The comparison `x == y`, where *x* and *y* are values, produces **true** or **false**. Such a comparison is performed as follows:

1. If `Type(x)` is the same as `Type(y)`, then
 - a. If `Type(x)` is `Undefined`, return **true**.

- b. If `Type(x)` is `Null`, return **true**.
 - c. If `Type(x)` is `Number`, then
 - i. If `x` is `NaN`, return **false**.
 - ii. If `y` is `NaN`, return **false**.
 - iii. If `x` is the same number value as `y`, return **true**.
 - iv. If `x` is `+0` and `y` is `-0`, return **true**.
 - v. If `x` is `-0` and `y` is `+0`, return **true**.
 - vi. Return **false**.
 - d. If `Type(x)` is `String`, then return **true** if `x` and `y` are exactly the same sequence of characters (same length and same characters in corresponding positions). Otherwise, return **false**.
 - e. If `Type(x)` is `Boolean`, return **true** if `x` and `y` are both **true** or both **false**. Otherwise, return **false**.
 - f. Return **true** if `x` and `y` refer to the same object. Otherwise, return **false**.
2. If `x` is **null** and `y` is **undefined**, return **true**.
 3. If `x` is **undefined** and `y` is **null**, return **true**.
 4. If `Type(x)` is `Number` and `Type(y)` is `String`, return the result of the comparison `x == ToNumber(y)`.
 5. If `Type(x)` is `String` and `Type(y)` is `Number`, return the result of the comparison `ToNumber(x) == y`.
 6. If `Type(x)` is `Boolean`, return the result of the comparison `ToNumber(x) == y`.
 7. If `Type(y)` is `Boolean`, return the result of the comparison `x == ToNumber(y)`.
 8. If `Type(x)` is either `String` or `Number` and `Type(y)` is `Object`, return the result of the comparison `x == ToPrimitive(y)`.
 9. If `Type(x)` is `Object` and `Type(y)` is either `String` or `Number`, return the result of the comparison `ToPrimitive(x) == y`.
 10. Return **false**.

NOTE

Given the above definition of equality:

String comparison can be forced by: `" " + a == " " + b`.

Numeric comparison can be forced by: `+a == +b`.

Boolean comparison can be forced by: `!a == !b`.

The equality operators maintain the following invariants:

A != B is equivalent to **!(A == B)**.

A == B is equivalent to **B == A**, except in the order of evaluation of **A** and **B**.

The equality operator is not always transitive. For example, there might be two distinct `String` objects, each representing the same string value; each `String` object would be considered equal to the string value by the `==` operator, but the two `String` objects would not be equal to each other.

Comparison of strings uses a simple equality test on sequences of code unit values. There is no attempt to use the more complex, semantically oriented definitions of character or string equality and collating order defined in the Unicode specification. Therefore strings that are canonically equal according to the Unicode standard could test as unequal. In effect this algorithm assumes that both strings are already in normalised form.

11.9.4 The Strict Equals Operator (`===`)

The production `EqualityExpression : EqualityExpression === RelationalExpression` is evaluated as follows:

1. Let `lref` be the result of evaluating `EqualityExpression`.
2. Let `lval` be `GetValue(lref)`.
3. Let `rref` be the result of evaluating `RelationalExpression`.
4. Let `rval` be `GetValue(rref)`.
5. Return the result of performing the strict equality comparison `rval === lval`. (See 11.9.6)

11.9.5 The Strict Does-not-equal Operator (**!==**)

The production *EqualityExpression* : *EqualityExpression* **!==** *RelationalExpression* is evaluated as follows:

1. Let *lref* be the result of evaluating *EqualityExpression*.
2. Let *lval* be *GetValue(lref)*.
3. Let *rref* be the result of evaluating *RelationalExpression*.
4. Let *rval* be *GetValue(rref)*.
5. Let *r* be the result of performing strict equality comparison *rval* **===** *lval*. (See 11.9.6)
6. If *r* is **true**, return **false**. Otherwise, return **true**.

11.9.6 The Strict Equality Comparison Algorithm

The comparison *x* **===** *y*, where *x* and *y* are values, produces **true** or **false**. Such a comparison is performed as follows:

1. If *Type(x)* is different from *Type(y)*, return **false**.
2. If *Type(x)* is Undefined, return **true**.
3. If *Type(x)* is Null, return **true**.
4. If *Type(x)* is Number, then
 - a. If *x* is **NaN**, return **false**.
 - b. If *y* is **NaN**, return **false**.
 - c. If *x* is the same number value as *y*, return **true**.
 - d. If *x* is **+0** and *y* is **-0**, return **true**.
 - e. If *x* is **-0** and *y* is **+0**, return **true**.
 - f. Return **false**.
5. If *Type(x)* is String, then return **true** if *x* and *y* are exactly the same sequence of characters (same length and same characters in corresponding positions); otherwise, return **false**.
6. If *Type(x)* is Boolean, return **true** if *x* and *y* are both **true** or both **false**; otherwise, return **false**.
7. Return **true** if *x* and *y* refer to the same object. Otherwise, return **false**.

NOTE

This algorithm differs from the SameValue Algorithm (9.12) in its treatment of signed zeroes and NaNs.

11.10 Binary Bitwise Operators

Syntax

BitwiseANDExpression :
EqualityExpression
BitwiseANDExpression **&** *EqualityExpression*

BitwiseANDExpressionNoIn :
EqualityExpressionNoIn
BitwiseANDExpressionNoIn **&** *EqualityExpressionNoIn*

BitwiseXORExpression :
BitwiseANDExpression
BitwiseXORExpression **^** *BitwiseANDExpression*

BitwiseXORExpressionNoIn :
BitwiseANDExpressionNoIn
BitwiseXORExpressionNoIn **^** *BitwiseANDExpressionNoIn*

BitwiseORExpression :
BitwiseXORExpression
BitwiseORExpression **|** *BitwiseXORExpression*

BitwiseORExpressionNoIn :
BitwiseXORExpressionNoIn
BitwiseORExpressionNoIn **|** *BitwiseXORExpressionNoIn*

Semantics

The production $A : A @ B$, where $@$ is one of the bitwise operators in the productions above, is evaluated as follows:

1. Let $lref$ be the result of evaluating A .
2. Let $lval$ be $GetValue(lref)$.
3. Let $rref$ be the result of evaluating B .
4. Let $rval$ be $GetValue(rref)$.
5. Let $lnum$ be $ToInt32(lval)$.
6. Let $rnum$ be $ToInt32(rval)$.
7. Return the result of applying the bitwise operator $@$ to $lnum$ and $rnum$. The result is a signed 32 bit integer.

11.11 Binary Logical Operators

Syntax

LogicalANDExpression :

BitwiseORExpression

LogicalANDExpression && *BitwiseORExpression*

LogicalANDExpressionNoIn :

BitwiseORExpressionNoIn

LogicalANDExpressionNoIn && *BitwiseORExpressionNoIn*

LogicalORExpression :

LogicalANDExpression

LogicalORExpression || *LogicalANDExpression*

LogicalORExpressionNoIn :

LogicalANDExpressionNoIn

LogicalORExpressionNoIn || *LogicalANDExpressionNoIn*

Semantics

The production *LogicalANDExpression* : *LogicalANDExpression* && *BitwiseORExpression* is evaluated as follows:

1. Let $lref$ be the result of evaluating *LogicalANDExpression*.
2. Let $lval$ be $GetValue(lref)$.
3. If $ToBoolean(lval)$ is **false**, return $lval$.
4. Let $rref$ be the result of evaluating *BitwiseORExpression*.
5. Return $GetValue(rref)$.

The production *LogicalORExpression* : *LogicalORExpression* || *LogicalANDExpression* is evaluated as follows:

1. Let $lref$ be the result of evaluating *LogicalORExpression*.
2. Let $lval$ be $GetValue(lref)$.
3. If $ToBoolean(lval)$ is **true**, return $lval$.
4. Let $rref$ be the result of evaluating *LogicalANDExpression*.
5. Return $GetValue(rref)$.

The *LogicalANDExpressionNoIn* and *LogicalORExpressionNoIn* productions are evaluated in the same manner as the *LogicalANDExpression* and *LogicalORExpression* productions except that the contained *LogicalANDExpressionNoIn*, *BitwiseORExpressionNoIn* and *LogicalORExpressionNoIn* are evaluated instead of the contained *LogicalANDExpression*, *BitwiseORExpression* and *LogicalORExpression*, respectively.

NOTE

The value produced by a **&&** or **||** operator is not necessarily of type Boolean. The value produced will always be the value of one of the two operand expressions.

11.12 Conditional Operator (? :)

Syntax

ConditionalExpression :

LogicalORExpression

LogicalORExpression ? *AssignmentExpression* : *AssignmentExpression*

ConditionalExpressionNoIn :

LogicalORExpressionNoIn

LogicalORExpressionNoIn ? *AssignmentExpression* : *AssignmentExpressionNoIn*

Semantics

The production *ConditionalExpression* : *LogicalORExpression* ? *AssignmentExpression* : *AssignmentExpression* is evaluated as follows:

1. Let *lref* be the result of evaluating *LogicalORExpression*.
2. If **ToBoolean(GetValue(*lref*))** is **true**, then
 - a. Let *trueRef* be the result of evaluating the first *AssignmentExpression*.
 - b. Return **GetValue(*trueRef*)**.
3. Else
 - a. Let *falseRef* be the result of evaluating the second *AssignmentExpression*.
 - b. Return **GetValue(*falseRef*)**.

The *ConditionalExpressionNoIn* production is evaluated in the same manner as the *ConditionalExpression* production except that the contained *LogicalORExpressionNoIn*, *AssignmentExpression* and *AssignmentExpressionNoIn* are evaluated instead of the contained *LogicalORExpression*, first *AssignmentExpression* and second *AssignmentExpression*, respectively.

NOTE

The grammar for a *ConditionalExpression* in ECMAScript is a little bit different from that in C and Java, which each allow the second subexpression to be an *Expression* but restrict the third expression to be a *ConditionalExpression*. The motivation for this difference in ECMAScript is to allow an assignment expression to be governed by either arm of a conditional and to eliminate the confusing and fairly useless case of a comma expression as the centre expression.

11.13 Assignment Operators

Syntax

AssignmentExpression :

ConditionalExpression

LeftHandSideExpression *AssignmentOperator* *AssignmentExpression*

AssignmentExpressionNoIn :

ConditionalExpressionNoIn

LeftHandSideExpression *AssignmentOperator* *AssignmentExpressionNoIn*

AssignmentOperator : one of

= *= /= %= += -= <<= >>= >>>= &= ^= |=

Semantics

The *AssignmentExpressionNoIn* productions are evaluated in the same manner as the *AssignmentExpression* productions except that the contained *ConditionalExpressionNoIn* and *AssignmentExpressionNoIn* are evaluated instead of the contained *ConditionalExpression* and *AssignmentExpression*, respectively.

11.13.1 Simple Assignment (=)

The production *AssignmentExpression* : *LeftHandSideExpression* = *AssignmentExpression* is evaluated as follows:

1. Let *lref* be the result of evaluating *LeftHandSideExpression*.
2. Let *rref* be the result of evaluating *AssignmentExpression*.
3. Let *rval* be *GetValue(rref)*.
4. Throw a **SyntaxError** exception if the following conditions are all true:
 - *Type(lref)* is Reference is **true**
 - *IsStrictReference(lref)* is **true**
 - *Type(GetBase(lref))* is Environment Record
 - *GetReferencedName(lref)* is "eval"
5. Call *PutValue(lref, rval)*.
6. Return *rval*.

NOTE

When an assignment occurs within strict mode code, its *LeftHandSide* must not evaluate to an unresolvable reference. If it does a **ReferenceError** exception is thrown upon assignment. The *LeftHandSide* also may not be a reference to a data property with the attribute value *[[Writable]]:false*, to an accessor property with the attribute value *[[Put]]:undefined*, nor to a non-existent property of an object whose *[[Extensible]]* internal property has the value **false**. In these cases a **TypeError** exception is thrown.

11.13.2 Compound Assignment (op=)

The production *AssignmentExpression* : *LeftHandSideExpression* @ = *AssignmentExpression*, where @ represents one of the operators indicated above, is evaluated as follows:

3. Let *lref* be the result of evaluating *LeftHandSideExpression*.
4. Let *lval* be *GetValue(lref)*.
5. Let *rref* be the result of evaluating *AssignmentExpression*.
6. Let *rval* be *GetValue(rref)*.
7. Let *r* be the result of applying operator @ to *lval* and *rval*.
8. Throw a **SyntaxError** exception if the following conditions are all true:
 - *Type(lref)* is Reference is **true**
 - *IsStrictReference(lref)* is **true**
 - *Type(GetBase(lref))* is Environment Record
 - *GetReferencedName(lref)* is "eval"
9. Call *PutValue(lref, r)*.
10. Return *r*.

NOTE

See NOTE 11.13.1.

11.14 Comma Operator (,)

Syntax

Expression :

AssignmentExpression

Expression , *AssignmentExpression*

ExpressionNoIn :

AssignmentExpressionNoIn

ExpressionNoIn , *AssignmentExpressionNoIn*

Semantics

The production *Expression* : *Expression* , *AssignmentExpression* is evaluated as follows:

1. Let *lref* be the result of evaluating *Expression*.
2. Call *GetValue(lref)*.
3. Let *rref* be the result of evaluating *AssignmentExpression*.
4. Return *GetValue(rref)*.

The *ExpressionNoIn* production is evaluated in the same manner as the *Expression* production except that the contained *ExpressionNoIn* and *AssignmentExpressionNoIn* are evaluated instead of the contained *Expression* and *AssignmentExpression*, respectively.

NOTE

GetValue must be called even though its value is not used because it may have observable side-effects.

DRAFT

12 Statements

Syntax

Statement :

Block
VariableStatement
EmptyStatement
ExpressionStatement
IfStatement
IterationStatement
ContinueStatement
BreakStatement
ReturnStatement
WithStatement
LabelledStatement
SwitchStatement
ThrowStatement
TryStatement
DebuggerStatement

Semantics

A *Statement* can be part of a *LabelledStatement*, which itself can be part of a *LabelledStatement*, and so on. The labels introduced this way are collectively referred to as the “current label set” when describing the semantics of individual statements. A *LabelledStatement* has no semantic meaning other than the introduction of a label to a *label set*. The label set of an *IterationStatement* or a *SwitchStatement* initially contains the single element **empty**. The label set of any other statement is initially empty.

NOTE

Several widely used implementations of ECMAScript are known to support the use of *FunctionDeclaration* as a *Statement*. However there are significant and irreconcilable variations among the implementations in the semantics applied to such *FunctionDeclarations*. Because of these irreconcilable difference, the use of a *FunctionDeclaration* as a *Statement* results in code that is not reliably portable among implementations. It is recommended that ECMAScript implementations either disallow this usage of *FunctionDeclaration* or issue a warning when such a usage is encountered. Future editions of ECMAScript may define alternative portable means for declaring functions in a *Statement* context.

12.1 Block

Syntax

Block :

{ *StatementList*_{opt} }

StatementList :

Statement
StatementList Statement

Semantics

The production *Block* : { } is evaluated as follows:

1. Return (**normal**, **empty**, **empty**).

The production *Block* : { *StatementList* } is evaluated as follows:

1. Return the result of evaluating *StatementList*.

The production *StatementList* : *Statement* is evaluated as follows:

1. Let *s* be the result of evaluating *Statement*.

2. If an exception was thrown, return (**throw**, V , empty) where V is the exception. (Execution now proceeds as if no exception were thrown.)
3. Return s .

The production *StatementList* : *StatementList Statement* is evaluated as follows:

1. Let sl be the result of evaluating *StatementList*.
2. If sl is an abrupt completion, return sl .
3. Let s be the result of evaluating *Statement*.
4. If an exception was thrown, return (**throw**, V , empty) where V is the exception. (Execution now proceeds as if no exception were thrown.)
5. If $s.value$ is **empty**, let $V = sl.value$, otherwise let $V = s.value$.
6. Return ($s.type$, V , $s.target$).

12.2 Variable statement

Syntax

VariableStatement :

var *VariableDeclarationList* ;

VariableDeclarationList :

VariableDeclaration

VariableDeclarationList , *VariableDeclaration*

VariableDeclarationListNoIn :

VariableDeclarationNoIn

VariableDeclarationListNoIn , *VariableDeclarationNoIn*

VariableDeclaration :

*Identifier Initialiser*_{opt}

VariableDeclarationNoIn :

*Identifier InitialiserNoIn*_{opt}

Initialiser :

= *AssignmentExpression*

InitialiserNoIn :

= *AssignmentExpressionNoIn*

Description

A variable statement declares variables that are created as defined in section 10.5. Variables are initialised to **undefined** when created. A variable with an *Initialiser* is assigned the value of its *AssignmentExpression* when the *VariableStatement* is executed, not when the variable is created.

Semantics

The production *VariableStatement* : **var** *VariableDeclarationList* ; is evaluated as follows:

1. Evaluate *VariableDeclarationList*.
2. Return (**normal**, **empty**, **empty**).

The production *VariableDeclarationList* : *VariableDeclaration* is evaluated as follows:

1. Evaluate *VariableDeclaration*.

The production *VariableDeclarationList* : *VariableDeclarationList* , *VariableDeclaration* is evaluated as follows:

1. Evaluate *VariableDeclarationList*.

2. Evaluate *VariableDeclaration*.

The production *VariableDeclaration* : *Identifier* is evaluated as follows:

1. Return a string value containing the same sequence of characters as in the *Identifier*.

The production *VariableDeclaration* : *Identifier Initialiser* is evaluated as follows:

1. Let *lhs* be the result of evaluating *Identifier* as described in 11.1.2.
2. Let *rhs* be the result of evaluating *Initialiser*.
3. Let *value* be GetValue(*rhs*).
4. Call PutValue(*lhs*, *value*).
5. Return a string value containing the same sequence of characters as in the *Identifier*.

NOTE

The string value of a *VariableDeclaration* is used in the evaluation of *for-in* statements (12.6.4).

If a *VariableDeclaration* is nested within a *with* statement and the *Identifier* in the *VariableDeclaration* is the same as a property name of the binding object of the *with* statement's object environment record, then step 4 will assign value to the property instead of to the *VariableEnvironment* binding of the *Identifier*.

The production *Initialiser* : = *AssignmentExpression* is evaluated as follows:

1. Return the result of evaluating *AssignmentExpression*.

The *VariableDeclarationListNoIn*, *VariableDeclarationNoIn* and *InitialiserNoIn* productions are evaluated in the same manner as the *VariableDeclarationList*, *VariableDeclaration* and *Initialiser* productions except that the contained *VariableDeclarationListNoIn*, *VariableDeclarationNoIn*, *InitialiserNoIn* and *AssignmentExpressionNoIn* are evaluated instead of the contained *VariableDeclarationList*, *VariableDeclaration*, *Initialiser* and *AssignmentExpression*, respectively.

12.2.1 Strict Mode Restrictions

It is a **SyntaxError** if a *VariableDeclaration* or *VariableDeclarationNoIn* occurs within strict code and its *Identifier* is either **"eval"** or **"arguments"**.

12.3 Empty Statement

Syntax

EmptyStatement :
;

Semantics

The production *EmptyStatement* : ; is evaluated as follows:

1. Return (**normal**, **empty**, **empty**).

12.4 Expression Statement

Syntax

ExpressionStatement :
[lookahead ∉ { {, function}] *Expression* ;

NOTE

An *ExpressionStatement* cannot start with an opening curly brace because that might make it ambiguous with a *Block*. Also, an *ExpressionStatement* cannot start with the **function** keyword because that might make it ambiguous with a *FunctionDeclaration*.

Semantics

The production *ExpressionStatement* : [lookahead ∉ { {, function}] *Expression* ; is evaluated as follows:

1. Let *exprRef* be the result of evaluating *Expression*.

2. Return (**normal**, GetValue(*exprRef*), **empty**).

12.5 The **if** Statement

Syntax

IfStatement :

```
if ( Expression ) Statement else Statement
if ( Expression ) Statement
```

Each **else** for which the choice of associated **if** is ambiguous shall be associated with the nearest possible **if** that would otherwise have no corresponding **else**.

Semantics

The production *IfStatement* : **if** (*Expression*) *Statement* **else** *Statement* is evaluated as follows:

1. Let *exprRef* be the result of evaluating *Expression*.
2. If ToBoolean(GetValue(*exprRef*)) is **true**, then
 - a. Return the result of evaluating the first *Statement*.
3. Else,
 - a. Return the result of evaluating the second *Statement*.

The production *IfStatement* : **if** (*Expression*) *Statement* is evaluated as follows:

1. Let *exprRef* be the result of evaluating *Expression*.
2. If ToBoolean(GetValue(*exprRef*)) is **false**, return (**normal**, **empty**, **empty**).
3. Return the result of evaluating *Statement*.

12.6 Iteration Statements

Syntax

IterationStatement :

```
do Statement while ( Expression ) ;
while ( Expression ) Statement
for ( ExpressionNoInopt ; Expressionopt ; Expressionopt ) Statement
for ( var VariableDeclarationListNoIn ; Expressionopt ; Expressionopt ) Statement
for ( LeftHandSideExpression in Expression ) Statement
for ( var VariableDeclarationNoIn in Expression ) Statement
```

12.6.1 The **do-while** Statement

The production **do** *Statement* **while** (*Expression*) ; is evaluated as follows:

1. Let *V* = **empty**.
2. Let *iterating* be **true**.
3. Repeat, while *iterating* is **true**
 - a. Let *stmt* be the result of evaluating *Statement*.
 - b. If *stmt*.value is not **empty**, let *V* = *stmt*.value.
 - c. If *stmt*.type is not **continue** || *stmt*.target is not in the current label set, then
 - i. If *stmt*.type is **break** and *stmt*.target is in the current label set, return (**normal**, *V*, **empty**).
 - ii. If *stmt* is an abrupt completion, return *stmt*.
 - d. Let *exprRef* be the result of evaluating *Expression*.
 - e. If ToBoolean(GetValue(*exprRef*)) is **false**, set *iterating* to **false**.
4. Return (**normal**, *V*, **empty**);

12.6.2 The **while** statement

The production *IterationStatement* : **while** (*Expression*) *Statement* is evaluated as follows:

1. Let *V* = **empty**.
2. Repeat
 - a. Let *exprRef* be the result of evaluating *Expression*.

- b. If `ToBoolean(GetValue(exprRef))` is **false**, return (**normal**, *V*, **empty**).
- c. Let *stmt* be the result of evaluating *Statement*.
- d. If *stmt.value* is not **empty**, let *V* = *stmt.value*.
- e. If *stmt.type* is not **continue** || *stmt.target* is not in the current label set, then
 - i. If *stmt.type* is **break** and *stmt.target* is in the current label set, then
 - 1. Return (**normal**, *V*, **empty**).
 - ii. If *stmt* is an abrupt completion, return *stmt*.

12.6.3 The for Statement

The production

IterationStatement : **for** (*ExpressionNoIn*_{opt} ; *Expression*_{opt} ; *Expression*_{opt}) *Statement*

is evaluated as follows:

1. If *ExpressionNoIn* is present, then.
 - a. Let *exprRef* be the result of evaluating *ExpressionNoIn*.
 - b. Call `GetValue(exprRef)`. (This value is not used.)
2. Let *V* = **empty**.
3. Repeat
 - a. If the first *Expression* is present, then
 - i. Let *testExprRef* be the result of evaluating the first *Expression*.
 - ii. If `GetValue(testExprRef)` is **false**, return (**normal**, *V*, **empty**).
 - b. Let *stmt* be the result of evaluating *Statement*.
 - c. If *stmt.value* is not **empty**, let *V* = *stmt.value*
 - d. If *stmt.type* is **break** and *stmt.target* is in the current label set, return (**normal**, *V*, **empty**).
 - e. If *stmt.type* is not **continue** || *stmt.target* is not in the current label set, then
 - i. If *stmt* is an abrupt completion, return *stmt*.
 - f. If the second *Expression* is present, then
 - i. Let *incExprRef* be the result of evaluating the second *Expression*.
 - ii. Call `GetValue(incExprRef)`. (This value is not used.)

The production

IterationStatement :

for (**var** *VariableDeclarationListNoIn* ; *Expression*_{opt} ; *Expression*_{opt}) *Statement*

is evaluated as follows:

1. Evaluate *VariableDeclarationListNoIn*.
2. Let *V* = **empty**.
3. Repeat
 - a. If the first *Expression* is present, then
 - i. Let *testExprRef* be the result of evaluating the first *Expression*.
 - ii. If `GetValue(testExprRef)` is **false**, then return (**normal**, *V*, **empty**).
 - b. Let *stmt* be the result of evaluating *Statement*.
 - c. If *stmt.value* is not **empty**, let *V* = *stmt.value*.
 - d. If *stmt.type* is **break** and *stmt.target* is in the current label set, return (**normal**, *V*, **empty**).
 - e. If *stmt.type* is not **continue** || *stmt.target* is not in the current label set, then
 - i. If *stmt* is an abrupt completion, return *stmt*.
 - f. If the second *Expression* is present, then
 - i. Let *incExprRef* be the result of evaluating the second *Expression*.
 - ii. Call `GetValue(incExprRef)`. (This value is not used.)

12.6.4 The for-in Statement

The production *IterationStatement* : **for** (*LeftHandSideExpression in Expression*) *Statement* is evaluated as follows:

1. Let *exprRef* be the result of evaluating the *Expression*.
2. Let *experValue* be `GetValue(exprRef)`.
3. If *experValue* is **null** or **undefined**, return (**normal**, **empty**, **empty**).
4. Let *obj* be `ToObject(experValue)`.

5. Let $V = \text{empty}$.
6. Repeat
 - a. Let P be the name of the next property of obj whose `[[Enumerable]]` attribute is **true**. If there is no such property, return (**normal**, V , **empty**).
 - b. Let $lhsRef$ be the result of evaluating the *LeftHandSideExpression* (it may be evaluated repeatedly).
 - c. Call `PutValue(lhsRef, P)`.
 - d. Let $stmt$ be the result of evaluating *Statement*.
 - e. If $stmt.value$ is not **empty**, let $V = stmt.value$.
 - f. If $stmt.type$ is **break** and $stmt.target$ is in the current label set, return (**normal**, V , **empty**).
 - g. If $stmt.type$ is not **continue** || $stmt.target$ is not in the current label set, then
 - i. If $stmt$ is an abrupt completion, return $stmt$.

The production

IterationStatement : **for** (**var** *VariableDeclarationNoIn* **in** *Expression*) *Statement*
 is evaluated as follows:

1. Let $varName$ be the result of evaluating *VariableDeclarationNoIn*.
2. Let $exprRef$ be the result of evaluating the *Expression*.
3. Let $experValue$ be `GetValue(exprRef)`.
4. If $experValue$ is **null** or **undefined**, return (**normal**, **empty**, **empty**).
5. Let obj be `ToObject(experValue)`.
6. Let $V = \text{empty}$.
7. Repeat
 - a. Let P be the name of the next property of obj whose `[[Enumerable]]` attribute is **true**. If there is no such property, return (**normal**, V , **empty**).
 - b. Let $varRef$ be the result of evaluating $varName$ as if it were an Identifier Reference (11.1.2); it may be evaluated repeatedly.
 - c. Call `PutValue(varRef, P)`.
 - d. Let $stmt$ be the result of evaluating *Statement*.
 - e. If $stmt.value$ is not **empty**, let $V = stmt.value$.
 - f. If $stmt.type$ is **break** and $stmt.target$ is in the current label set, return (**normal**, V , **empty**).
 - g. If $stmt.type$ is not **continue** || $stmt.target$ is not in the current label set, then
 - i. If $stmt$ is an abrupt completion, return $stmt$.

The mechanics and order of enumerating the properties (step 6.a in the first algorithm, step 7.a in the second) is not specified. Properties of the object being enumerated may be deleted during enumeration. If a property that has not yet been visited during enumeration is deleted, then it will not be visited. If new properties are added to the object being enumerated during enumeration, the newly added properties are guaranteed not to be visited in the active enumeration.

Enumerating the properties of an object includes enumerating properties of its prototype, and the prototype of the prototype, and so on, recursively; but a property of a prototype is not enumerated if it is “shadowed” because some previous object in the prototype chain has a property with the same name.

NOTE

See *NOTE 11.13.1*.

12.7 The continue Statement

Syntax

ContinueStatement :

continue [no *LineTerminator* here] *Identifier*_{opt} ;

Semantics

A program is considered syntactically incorrect if either of the following is true:

- The program contains a **continue** statement without the optional *Identifier*, which is not nested, directly or indirectly (but not crossing function boundaries), within an *IterationStatement*.

- The program contains a **continue** statement with the optional *Identifier*, where *Identifier* does not appear in the label set of an enclosing (but not crossing function boundaries) *IterationStatement*.

A *ContinueStatement* without an *Identifier* is evaluated as follows:

1. Return (**continue**, **empty**, **empty**).

A *ContinueStatement* with the optional *Identifier* is evaluated as follows:

1. Return (**continue**, **empty**, *Identifier*).

12.8 The **break** Statement

Syntax

BreakStatement :

break [no *LineTerminator* here] *Identifier*_{opt} ;

Semantics

A program is considered syntactically incorrect if either of the following is true:

- The program contains a **break** statement without the optional *Identifier*, which is not nested, directly or indirectly (but not crossing function boundaries), within an *IterationStatement* or a *SwitchStatement*.
- The program contains a **break** statement with the optional *Identifier*, where *Identifier* does not appear in the label set of an enclosing (but not crossing function boundaries) *Statement*.

A *BreakStatement* without an *Identifier* is evaluated as follows:

1. Return (**break**, **empty**, **empty**).

A *BreakStatement* with an *Identifier* is evaluated as follows:

1. Return (**break**, **empty**, *Identifier*).

12.9 The **return** Statement

Syntax

ReturnStatement :

return [no *LineTerminator* here] *Expression*_{opt} ;

Semantics

An ECMAScript program is considered syntactically incorrect if it contains a **return** statement that is not within a *FunctionBody*. A **return** statement causes a function to cease execution and return a value to the caller. If *Expression* is omitted, the return value is **undefined**. Otherwise, the return value is the value of *Expression*.

The production *ReturnStatement* : **return** [no *LineTerminator* here] *Expression*_{opt} ; is evaluated as:

1. If the *Expression* is not present, return (**return**, **undefined**, **empty**).
2. Let *exprRef* be the result of evaluating *Expression*.
3. Return (**return**, *GetValue*(*exprRef*), **empty**).

12.10 The **with** Statement

Syntax

WithStatement :

with (*Expression*) *Statement*

Description

The **with** statement adds an object environment record for a computed object to the lexical environment of the current execution context. It then executes a statement using this augmented lexical environment. Finally, it restores the original lexical environment.

Semantics

The production *WithStatement* : **with** (*Expression*) *Statement* is evaluated as follows:

1. Let *val* be the result of evaluating *Expression*.
2. Let *obj* be ToObject(GetValue(*val*)).
3. Let *oldEnv* be the running execution context's LexicalEnvironment.
4. Let *newEnv* be the result of calling NewObjectEnvironment passing *obj* and *oldEnv* as the arguments
5. Set the *provideThis* flag of *newEnv* to **true**.
6. Set the running execution context's LexicalEnvironment to *newEnv*.
7. Let *C* be the result of evaluating *Statement* but if an exception is thrown during the evaluation, let *C* be (**throw**, *V*, **empty**), where *V* is the exception. (Execution now proceeds as if no exception were thrown.)
8. Set the running execution context's Lexical Environment to *oldEnv*.
9. Return *C*.

NOTE

No matter how control leaves the embedded '*Statement*', whether normally or by some form of abrupt completion or exception, the LexicalEnvironment is always restored to its former state.

12.10.1 Strict Mode Restrictions

Strict mode code may not include a *WithStatement*. The occurrence of a *WithStatement* in such a context is treated as a **SyntaxError**.

12.11 The switch Statement

Syntax

SwitchStatement :

switch (*Expression*) *CaseBlock*

CaseBlock :

{ *CaseClauses*_{opt} }
{ *CaseClauses*_{opt} *DefaultClause* *CaseClauses*_{opt} }

CaseClauses :

CaseClause
CaseClauses *CaseClause*

CaseClause :

case *Expression* : *StatementList*_{opt}

DefaultClause :

default : *StatementList*_{opt}

Semantics

The production *SwitchStatement* : **switch** (*Expression*) *CaseBlock* is evaluated as follows:

1. Let *exprRef* be the result of evaluating *Expression*.
2. Let *R* be the result of evaluating *CaseBlock*, passing it GetValue(*exprRef*) as a parameter.
3. If *R.type* is **break** and *R.target* is in the current label set, return (**normal**, *R.value*, **empty**).
4. Return *R*.

The production *CaseBlock* : { *CaseClauses*_{opt} } is given an input parameter, *input*, and is evaluated as follows:

1. Let $V = \text{empty}$.
2. Let A be the list of *CaseClause* items in source text order.
3. Let *searching* be **true**.
4. Repeat, while *searching* is **true**
 - a. Let C be the next *CaseClause* in A . If there is no such *CaseClause*, return (**normal**, V , **empty**).
 - b. Let *clauseSelector* be the result of evaluating C .
 - c. If *input* is equal to *clauseSelector* as defined by the `===` operator, then
 - i. Set *searching* to **false**.
 - ii. If C has a *StatementList*, then
 1. Evaluate C 's *StatementList* and let R be the result.
 2. If R is an abrupt completion, then return R .
 3. Let $V = R.value$.
5. Repeat
 - b. Let C be the next *CaseClause* in A . If there is no such *CaseClause*, return (**normal**, V , **empty**).
 - c. If C has a *StatementList*, then
 - i. Evaluate C 's *StatementList* and let R be the result.
 - ii. If $R.value$ is not **empty**, then let $V = R.value$.
 - iii. If R is an abrupt completion, then return ($R.type$, V , $R.target$).

The production *CaseBlock* : { *CaseClauses_{opt}* *DefaultClause* *CaseClauses_{opt}* } is given an input parameter, *input*, and is evaluated as follows:

1. Let $V = \text{empty}$.
2. Let A be the list of *CaseClause* items in the first *CaseClauses*, in source text order.
3. Let B be the list of *CaseClause* items in the second *CaseClauses*, in source text order.
4. Let *found* be **false**.
5. Repeat letting C be in order each *CaseClause* in A
 - a. If *found* is **false**, then
 - i. Let *clauseSelector* be the result of evaluating C .
 - ii. If *input* is equal to *clauseSelector* as defined by the `===` operator, then set *found* to **true**.
 - b. If *found* is **true**, then
 - i. If C has a *StatementList*, then
 1. Evaluate C 's *StatementList* and let R be the result.
 2. If $R.value$ is not **empty**, then let $V = R.value$.
 3. R is an abrupt completion, then return ($R.type$, V , $R.target$).
6. Let *foundInB* be **false**.
7. If *found* is **false**, then
 - a. Repeat, while *foundInB* is **false** and all elements of B have not been processed
 - i. Let C be the next *CaseClause* in B .
 - ii. Let *clauseSelector* be the result of evaluating C .
 - iii. If *input* is equal to *clauseSelector* as defined by the `===` operator, then
 1. Set *foundInB* to **true**.
 2. If C has a *StatementList*, then
 - a. Evaluate C 's *StatementList* and let R be the result.
 - b. If $R.value$ is not **empty**, then let $V = R.value$.
 - c. R is an abrupt completion, then return ($R.type$, V , $R.target$).
8. If *foundInB* is **false** and the *DefaultClause* has a *StatementList*, then
 - a. Evaluate the *DefaultClause*'s *StatementList* and let R be the result.
 - b. If $R.value$ is not **empty**, then let $V = R.value$.
 - c. If R is an abrupt completion, then return ($R.type$, V , $R.target$).
9. Repeat (Note that if step 7.a.i has been performed this loop does not start at the beginning of B)
 - a. Let C be the next *CaseClause* in B . If there is no such *CaseClause*, return (**normal**, V , **empty**).
 - b. If C has a *StatementList*, then
 - i. Evaluate C 's *StatementList* and let R be the result.
 - ii. If $R.value$ is not **empty**, then let $V = R.value$.
 - iii. If R is an abrupt completion, then return ($R.type$, V , $R.target$).

The production *CaseClause* : **case** *Expression* : *StatementList_{opt}* is evaluated as follows:

1. Let *exprRef* be the result of evaluating *Expression*.
2. Return `GetValue(exprRef)`.

NOTE

Evaluating CaseClause does not execute the associated StatementList. It simply evaluates the Expression and returns the value, which the CaseBlock algorithm uses to determine which StatementList to start executing.

12.12 Labelled Statements

Syntax

LabelledStatement :

Identifier : *Statement*

Semantics

A *Statement* may be prefixed by a label. Labelled statements are only used in conjunction with labelled **break** and **continue** statements. ECMAScript has no **goto** statement.

An ECMAScript program is considered syntactically incorrect if it contains a *LabelledStatement* that is enclosed by a *LabelledStatement* with the same *Identifier* as label. This does not apply to labels appearing within the body of a *FunctionDeclaration* that is nested, directly or indirectly, within a labelled statement.

The production *Identifier* : *Statement* is evaluated by adding *Identifier* to the label set of *Statement* and then evaluating *Statement*. If the *LabelledStatement* itself has a non-empty label set, these labels are also added to the label set of *Statement* before evaluating it. If the result of evaluating *Statement* is (**break**, *V*, *L*) where *L* is equal to *Identifier*, the production results in (**normal**, *V*, **empty**).

Prior to the evaluation of a *LabelledStatement*, the contained *Statement* is regarded as possessing an empty label set, except if it is an *IterationStatement* or a *SwitchStatement*, in which case it is regarded as possessing a label set consisting of the single element, **empty**.

12.13 The **throw** statement

Syntax

ThrowStatement :

throw [no *LineTerminator* here] *Expression* ;

Semantics

The production *ThrowStatement* : **throw** [no *LineTerminator* here] *Expression* ; is evaluated as:

1. Let *exprRef* be the result of evaluating *Expression*.
2. Return (**throw**, `GetValue(exprRef)`, **empty**).

12.14 The **try** statement

Syntax

TryStatement :

try *Block* *Catch*

try *Block* *Finally*

try *Block* *Catch* *Finally*

Catch :

catch (*Identifier*) *Block*

Finally :

finally *Block*

Description

The **try** statement encloses a block of code in which an exceptional condition can occur, such as a runtime error or a **throw** statement. The **catch** clause provides the exception-handling code. When a catch clause catches an exception, its *Identifier* is bound to that exception.

Semantics

The production *TryStatement* : **try** *Block* *Catch* is evaluated as follows:

1. Let *B* be the result of evaluating *Block*.
2. If *B.type* is not **throw**, return *B*.
3. Return the result of evaluating *Catch* with parameter *B*.

The production *TryStatement* : **try** *Block* *Finally* is evaluated as follows:

1. Let *B* be the result of evaluating *Block*.
2. Let *F* be the result of evaluating *Finally*.
3. If *F.type* is **normal**, return *B*.
4. Return *F*.

The production *TryStatement* : **try** *Block* *Catch* *Finally* is evaluated as follows:

1. Let *B* be the result of evaluating *Block*.
2. If *B.type* is **throw**, then
 - a. Let *C* be the result of evaluating *Catch* with parameter *B*.
3. Else, *B.type* is not **throw**,
 - a. Let *C* be *B*.
4. Let *F* be the result of evaluating *Finally*.
5. If *F.type* is **normal**, return *C*.
6. Return *F*.

The production *Catch* : **catch** (*Identifier*) *Block* is evaluated as follows:

1. Let *C* be the parameter that has been passed to this production.
2. Let *oldEnv* be the running execution context's `LexicalEnvironment`.
3. Let *catchEnv* be the result of calling `NewDeclarativeEnvironment` passing *oldEnv* as the argument.
4. Call the `CreateMutableBinding` concrete method of *catchEnv* passing the *Identifier* String value as the argument.
5. Call the `SetMutableBinding` concrete method of *catchEnv* passing the *Identifier*, *C*, and **false** as arguments. Note that the last argument is immaterial in this situation.
6. Set the running execution context's `LexicalEnvironment` to *catchEnv*.
7. Let *B* be the result of evaluating *Block*.
8. Set the running execution context's `LexicalEnvironment` to *oldEnv*.
9. Return *B*.

NOTE

No matter how control leaves the Block the `LexicalEnvironment` is always restored to its former state.

The production *Finally* : **finally** *Block* is evaluated as follows:

1. Return the result of evaluating *Block*.

12.14.1 Strict Mode Restrictions

It is an **SyntaxError** if a *TryStatement* with a *Catch* occurs within strict code and the *Identifier* of the *Catch* production is either **"eval"** or **"arguments"**.

12.15 Debugger statement

Syntax

```
DebuggerStatement :  
  debugger ;
```

Semantics

Evaluating the *DebuggerStatement* production may allow an implementation to cause a breakpoint when run under a debugger. If a debugger is not present or active this statement has no observable effect.

The production *DebuggerStatement* : **debugger** ; is evaluated as follows:

1. If an implementation defined debugging facility is available and enabled, then
 - a. Perform an implementation defined debugging action.
 - b. Let *result* be an implementation defined Completion value.
2. Else
 - a. Let *result* be (**normal, empty, empty**).
3. Return *result*.

DRAFT

13 Function Definition

Syntax

FunctionDeclaration :

function *Identifier* (*FormalParameterList_{opt}*) { *FunctionBody* }

FunctionExpression :

function *Identifier_{opt}* (*FormalParameterList_{opt}*) { *FunctionBody* }

FormalParameterList :

Identifier

FormalParameterList , *Identifier*

FunctionBody :

SourceElements_{opt}

Semantics

The production

FunctionDeclaration : **function** *Identifier* (*FormalParameterList_{opt}*) { *FunctionBody* }

is instantiated as follows during Declaration Binding instantiation (10.5):

1. Return the result of creating a new Function object as specified in 13.2 with parameters specified by *FormalParameterList_{opt}*, and body specified by *FunctionBody*. Pass in the VariableEnvironment of the running execution context as the *Scope*. Pass in **true** as the *Strict* flag if the *FunctionDeclaration* is contained in strict code or if its *FunctionBody* is strict code.

The production

FunctionExpression : **function** (*FormalParameterList_{opt}*) { *FunctionBody* }

is evaluated as follows:

1. Return the result of creating a new Function object as specified in 13.2 with parameters specified by *FormalParameterList_{opt}* and body specified by *FunctionBody*. Pass in the LexicalEnvironment of the running execution context as the *Scope*. Pass in **true** as the *Strict* flag if the *FunctionExpression* is contained in strict code or if its *FunctionBody* is strict code.

The production

FunctionExpression : **function** *Identifier* (*FormalParameterList_{opt}*) { *FunctionBody* }

is evaluated as follows:

1. Let *funcEnv* be the result of calling `NewDeclarativeEnvironment` passing the running execution context's Lexical Environment as the argument
2. Let *envRec* be *funcEnv*'s environment record.
3. Call the `CreateImmutableBinding(N)` concrete method of *envRec* passing the string value of *Identifier* as the argument.
4. Let *closure* be the result of creating a new Function object as specified in 13.2 with parameters specified by *FormalParameterList_{opt}* and body specified by *FunctionBody*. Pass in *funcEnv* as the *Scope*. Pass in **true** as the *Strict* flag if the *FunctionExpression* is contained in strict code or if its *FunctionBody* is strict code.
5. Call the `InitializeImmutableBinding(N,V)` concrete method of *envRec* passing the string value of *Identifier* and *closure* as the arguments.
6. Return *closure*.

NOTE

The Identifier in a FunctionExpression can be referenced from inside the FunctionExpression's FunctionBody to allow the function to call itself recursively. However, unlike in a FunctionDeclaration, the Identifier in a FunctionExpression cannot be referenced from and does not affect the scope enclosing the FunctionExpression.

The production *FunctionBody* : *SourceElements*_{opt} is evaluated as follows:

1. The code of this *FunctionBody* is strict mode code if it is part of a *FunctionDeclaration* or *FunctionExpression* that is contained in strict mode code or if the Directive Prologue (14.1) of its *SourceElements* contains a Use Strict Directive or if any of the conditions in 10.1.1 apply. If the code of this *FunctionBody* is strict mode code, *SourceElements* is evaluated in the following steps as strict mode code. Otherwise, *SourceElements* is evaluated in the following steps as non-strict mode code.
2. If *SourceElements* is present return the result of evaluating *SourceElements*.
3. Else return (**normal**, **undefined**, **empty**).

13.1 Strict Mode Restrictions

It is a **SyntaxError** if any *Identifier* value appears more than once within a *FormalParameterList* of a strict mode *FunctionDeclaration* or *FunctionExpression*.

It is a **SyntaxError** if the *Identifier* "eval" or the *Identifier* "arguments" appears within a *FormalParameterList* of a strict mode *FunctionDeclaration* or *FunctionExpression*.

It is a **SyntaxError** if the *Identifier* "eval" or the *Identifier* "arguments" appears as the *Identifier* of a strict mode *FunctionDeclaration* or *FunctionExpression*.

13.2 Creating Function Objects

Given an optional parameter list specified by *FormalParameterList*, a body specified by *FunctionBody*, a Lexical Environment specified by *Scope*, and a Boolean flag *Strict*, a Function object is constructed as follows:

1. Create a new native ECMAScript object and let *F* be that object.
2. Set the `[[Class]]` internal property of *F* to "Function".
3. Set the `[[Prototype]]` internal property of *F* to the standard built-in Function prototype object as specified in 15.3.3.1.
4. Set the `[[Get]]` internal property of *F* as described in 15.3.5.4.
5. Set the `[[Call]]` internal property of *F* as described in 13.2.1.
6. Set the `[[Construct]]` internal property of *F* as described in 13.2.2.
7. Set the `[[HasInstance]]` internal property of *F* as described in 15.3.5.3.
8. Set the `[[Scope]]` internal property of *F* to the value of *Scope*.
9. Let *names* be a List containing, in left to right textual order, the strings corresponding to the identifiers of *FormalParameterList*.
10. Set the `[[FormalParameters]]` internal property of *F* to *names*.
11. Set the `[[Code]]` internal property of *F* to *FunctionBody*.
12. Set the `[[Extensible]]` internal property of *F* to **true**.
13. Let *len* be the number of formal parameters specified in *FormalParameterList*. If no parameters are specified, let *len* be 0.
14. Call the `[[DefineOwnProperty]]` internal method of *F* with arguments "length", Property Descriptor `{[[Value]]: len, [[Writable]]: false, [[Enumerable]]: false, [[Configurable]]: false}`, and **false**.
15. Let *proto* be the result of creating a new object as would be constructed by the expression **new Object()** where **Object** is the standard built-in constructor with that name.
16. Call the `[[DefineOwnProperty]]` internal method of *proto* with arguments "constructor", Property Descriptor `{[[Value]]: F, { [[Writable]]: true, [[Enumerable]]: false, [[Configurable]]: true}`, and **false**.
17. Call the `[[DefineOwnProperty]]` internal method of *F* with arguments "prototype", Property Descriptor `{[[Value]]: proto, { [[Writable]]: true, [[Enumerable]]: false, [[Configurable]]: false}`, and **false**.
18. If *Strict* is **true**, then
 - a. Let *thrower* be the `[[ThrowTypeError]]` function Object (13.2.3).
 - b. Call the `[[DefineOwnProperty]]` internal method of *F* with arguments "caller", PropertyDescriptor `{[[Get]]: thrower, [[Set]]: thrower, [[Enumerable]]: false, [[Configurable]]: false}`, and **false**.
 - c. Call the `[[DefineOwnProperty]]` internal method of *F* with arguments "arguments", PropertyDescriptor `{[[Get]]: thrower, [[Set]]: thrower, [[Enumerable]]: false, [[Configurable]]: false}`, and **false**.

19. Return *F*.

NOTE

A **prototype** property is automatically created for every function, to allow for the possibility that the function will be used as a constructor.

13.2.1 **[[Call]]**

When the **[[Call]]** internal method for a Function object *F* is called with a **this** value and a list of arguments, the following steps are taken:

1. Let *funcCtx* be the result of establishing a new execution context for function code using the value of *F*'s **[[FormalParameters]]** internal property, the passed arguments List *args*, and the **this** value as described in 10.4.3.
2. Let *result* be the result of evaluating the *FunctionBody* that is the value of *F*'s **[[Code]]** internal property. If *F* does not have a **[[Code]]** internal property or if its value is an empty *FunctionBody*, then *result* is (**normal, undefined, empty**).
3. Exit the execution context *funcCtx*, restoring the previous execution context.
4. If *result.type* is **throw** then throw *result.value*.
5. If *result.type* is **return** then return *result.value*.
6. Otherwise *result.type* must be **normal**. Return **undefined**.

13.2.2 **[[Construct]]**

When the **[[Construct]]** internal method for a Function object *F* is called with a possibly empty list of arguments, the following steps are taken:

1. Let *obj* be a newly created native ECMAScript object.
2. Set the **[[Class]]** internal property of *obj* to **"Object"**.
3. Set the **[[Extensible]]** internal property of *obj* to **true**.
4. Let *proto* be the value of calling the **[[Get]]** internal property of *F* with argument **"prototype"**.
5. If Type(*proto*) is Object, set the **[[Prototype]]** internal property of *obj* to *proto*.
6. If Type(*proto*) is not Object, set the **[[Prototype]]** internal property of *obj* to the standard built-in Object prototype object as described in 15.2.4.
7. Let *result* be the result of calling the **[[Call]]** internal property of *F*, providing *obj* as the **this** value and providing the argument list passed into **[[Construct]]** as *args*.
8. If Type(*result*) is Object then return *result*.
9. Return *obj*.

13.2.3 The **[[ThrowTypeError]]** Function Object

The **[[ThrowTypeError]]** object is a unique function object that is defined once as follows:

1. Create a new native ECMAScript object and let *F* be that object.
2. Set the **[[Class]]** internal property of *F* to **"Function"**.
3. Set the **[[Prototype]]** internal property of *F* to the standard built-in Function prototype object as specified in 15.3.3.1.
4. Set the **[[Call]]** internal property of *F* as described in 13.2.1.
5. Set the **[[Scope]]** internal property of *F* to the Global Environment.
6. Set the **[[FormalParameters]]** internal property of *F* to an empty List.
7. Set the **[[Code]]** internal property of *F* to be a *FunctionBody* that unconditionally throws a **TypeError** exception and performs no other action.
8. Call the **[[DefineOwnProperty]]** internal method of *F* with arguments **"length"**, Property Descriptor **{[[Value]]: 0, [[Writable]]: false, [[Enumerable]]: false, [[Configurable]]: false}**, and **false**.
9. Set the **[[Extensible]]** internal property of *F* to **false**.
10. Let **[[ThrowTypeError]]** be *F*.

14 Program

Syntax

Program :

*SourceElements*_{opt}

SourceElements :

SourceElement

SourceElements SourceElement

SourceElement :

Statement

FunctionDeclaration

Semantics

The production *Program* : *SourceElements*_{opt} is evaluated as follows:

1. The code of this *Program* is strict mode code if the Directive Prologue (14.1) of its *SourceElements* contains a Use Strict Directive or if any of the conditions of 10.1.1 apply. If the code of this *Program* is strict mode code, *SourceElements* is evaluated in the following steps as strict mode code. Otherwise *SourceElements* is evaluated in the following steps as non-strict mode code.
2. If *SourceElements* is not present, return (**normal**, **empty**, **empty**).
3. Let *progCxt* be a new execution context for global code as described in 10.4.1.
4. Let *result* be the result of evaluating *SourceElements*.
5. Exit the execution context *progCxt*.
6. Return *result*.

NOTE

The processes for initiating the evaluation of a *Program* and for dealing with the result of such an evaluation are defined by an ECMAScript implementation and not by this specification.

The production *SourceElements* : *SourceElements SourceElement* is evaluated as follows:

1. Let *headResult* be the result of evaluating *SourceElements*.
2. If *headResult* is an abrupt completion, return *headResult*.
3. Let *tailResult* be result of evaluating *SourceElement*.
4. If *tailResult*.value is **empty**, let *V* = *headResult*.value, otherwise let *V* = *tailResult*.value.
5. Return (*tailResult*.type, *V*, *tailResult*.target)

The production *SourceElement* : *Statement* is evaluated as follows:

1. Return the result of evaluating *Statement*.

The production *SourceElement* : *FunctionDeclaration* is evaluated as follows:

1. Return (**normal**, **empty**, **empty**).

14.1 Directive Prologues and the Use Strict Directive

A Directive Prologue is a sequence of zero or more *ExpressionStatement* productions, each of which consists entirely of a *StringLiteral*, that occur as the initial *SourceElement* productions of a *Program* or *FunctionBody*.

A Use Strict Directive is an *ExpressionStatement* in a Directive Prologue whose *StringLiteral* is either the exact character sequences "**use strict**" or '**use strict**'. A Use Strict Directive may not contain an *EscapeSequence* or *LineContinuation*.

NOTE

The *ExpressionStatement* productions of a Directive Prologue are evaluated normally during evaluation of the containing *SourceElements* production. Implementations may define implementation specific meanings for *ExpressionStatement* productions which are not a Use Strict Directive and which occur in a Directive

Prologue. If an appropriate notification mechanism exists, an implementation should issue a warning if it encounters in a Directive Prologue an ExpressionStatement that is not a Use Strict Directive or which does not have a meaning defined by the implementation.

A Directive Prologue may contain more than one Use Strict Directive. However, an implementation may issue a warning if this occurs.

DRAFT

15 Standard Built-in ECMAScript Objects

There are certain built-in objects available whenever an ECMAScript program begins execution. One, the global object, is part of the lexical environment of the executing program. Others are accessible as initial properties of the global object.

Unless specified otherwise, the `[[Class]]` internal property of a built-in object is **"Function"** if that built-in object has a `[[Call]]` property, or **"Object"** if that built-in object does not have a `[[Call]]` internal property. Unless specified otherwise, the `[[Extensible]]` internal property of a built-in object initially has the value **true**.

Many built-in objects are functions: they can be invoked with arguments. Some of them furthermore are constructors: they are functions intended for use with the **new** operator. For each built-in function, this specification describes the arguments required by that function and properties of the Function object. For each built-in constructor, this specification furthermore describes properties of the prototype object of that constructor and properties of specific object instances returned by a **new** expression that invokes that constructor.

Unless otherwise specified in the description of a particular function, if a function or constructor described in this section is given fewer arguments than the function is specified to require, the function or constructor shall behave exactly as if it had been given sufficient additional arguments, each such argument being the **undefined** value.

Unless otherwise specified in the description of a particular function, if a function or constructor described in this section is given more arguments than the function is specified to allow, the extra arguments are evaluated by the call and then ignored by the function. However, an implementation may define implementation specific behaviour relating to such arguments as long as the behaviour is not the throwing of a `TypeError` exception that is predicated simply on the presence of an extra argument.

NOTE

Implementations that add additional capabilities to the set of built-in functions are encouraged to do so by adding new functions rather than adding new parameters to existing functions.

Every built-in function and every built-in constructor has the Function prototype object, which is the initial value of the expression **Function.prototype** (15.3.4), as the value of its `[[Prototype]]` internal property.

Unless otherwise specified every built-in prototype object has the Object prototype object, which is the initial value of the expression **Object.prototype** (15.2.4), as the value of its `[[Prototype]]` internal property, except the Object prototype object itself.

None of the built-in functions described in this section that are not constructors shall implement the `[[Construct]]` internal method unless otherwise specified in the description of a particular function. None of the built-in functions described in this section shall have a **prototype** property unless otherwise specified in the description of a particular function.

This section generally describes distinct behaviours for when a constructor is “called as a function” and for when it is “called as part of a **new** expression”. The “called as a function” behaviour corresponds to the invocation of the constructor’s `[[Call]]` internal method and the “called as part of a new expression” behaviour corresponds to the invocation of the constructor’s `[[Construct]]` internal method.

Every built-in Function object described in this section—whether as a constructor, an ordinary function, or both—has a **length** property whose value is an integer. Unless otherwise specified, this value is equal to the largest number of named arguments shown in the section headings for the function description, including optional parameters.

NOTE

For example, the Function object that is the initial value of the `slice` property of the String prototype object is described under the section heading “`String.prototype.slice (start, end)`” which shows the two named arguments `start` and `end`; therefore the value of the `length` property of that Function object is 2.

In every case, the **length** property of a built-in Function object described in this section has the attributes { `[[Writable]]`: **false**, `[[Enumerable]]`: **false**, `[[Configurable]]`: **false** }. Every other property described in this section has the attributes { `[[Writable]]`: **true**, `[[Enumerable]]`: **false**, `[[Configurable]]`: **true** } unless otherwise specified.

15.1 The Global Object

The unique *global object* is created before control enters any execution context.

Unless otherwise specified, the standard built-in properties of the global object have attributes {[[Writable]]: **true**, [[Enumerable]]: **false**, [[Configurable]]: **true**}.

The global object does not have a [[Construct]] internal property; it is not possible to use the global object as a constructor with the **new** operator.

The global object does not have a [[Call]] internal property; it is not possible to invoke the global object as a function.

The values of the [[Prototype]] and [[Class]] internal properties of the global object are implementation-dependent.

In addition to the properties defined in this specification the global object may have additional host defined properties. This may include a property whose value is the global object itself; for example, in the HTML document object model the **window** property of the global object is the global object itself.

15.1.1 Value Properties of the Global Object

15.1.1.1 NaN

The value of **NaN** is **NaN** (8.5). This property has the attributes { [[Writable]]: **false**, [[Enumerable]]: **false**, [[Configurable]]: **false** }.

15.1.1.2 Infinity

The value of **Infinity** is $+\infty$ (8.5). This property has the attributes { [[Writable]]: **false**, [[Enumerable]]: **false**, [[Configurable]]: **false** }.

15.1.1.3 undefined

The value of **undefined** is **undefined** (8.1). This property has the attributes { [[Writable]]: **false**, [[Enumerable]]: **false**, [[Configurable]]: **false** }.

15.1.2 Function Properties of the Global Object

15.1.2.1 eval (x)

When the **eval** function is called with one argument *x*, the following steps are taken:

1. If *x* is not a string value, return *x*.
2. Let *prog* be the ECMAScript code that is the result of parsing *x* as a *Program*. If the parse fails, throw a **SyntaxError** exception (but see also clause 16).
3. Let *evalCtx* be the result of establishing a new execution context (10.4.2) for the eval code *prog*.
4. Let *result* be the result of evaluating the program *prog*.
5. Exit the running execution context *evalCtx*, restoring the previous execution context.
6. If *result.type* is **normal** and its completion value is a value *V*, then return the value *V*.
7. If *result.type* is **normal** and its completion value is **empty**, then return the value **undefined**.
8. Otherwise, *result.type* must be **throw**. Throw *result.value* as an exception.

15.1.2.1.1 Direct Call to Eval

A direct call to the **eval** function is one that is expressed as a *CallExpression* that meets the following two conditions:

- The Reference that is the result of evaluating the *MemberExpression* in the *CallExpression* has an environment record as its base value and its reference name is "**eval**".
- The result of calling the abstract operation GetValue with that Reference as the argument is the standard built-in function defined in 15.1.2.1.

15.1.2.2 parseInt (string , radix)

The **parseInt** function produces an integer value dictated by interpretation of the contents of the *string* argument according to the specified *radix*. Leading white space in the string is ignored. If *radix* is **undefined** or 0, it is assumed to be 10 except when the number begins with the character pairs **0x**

or **0x**, in which case a radix of 16 is assumed. If *radix* is 16 number may also optionally begin with the character pairs **0x** or **0X**.

When the **parseInt** function is called, the following steps are taken:

1. Let *inputString* be ToString(*string*).
2. Let *S* be a newly created substring of *inputString* consisting of the first character that is not a *StrWhiteSpaceChar* and all characters following that character. (In other words, remove leading white space.)
3. Let *sign* be 1.
4. If *S* is not empty and the first character of *S* is a minus sign **-**, let *sign* be **-1**.
5. If *S* is not empty and the first character of *S* is a plus sign **+** or a minus sign **-**, then remove the first character from *S*.
6. Let *R* = ToInt32(*radix*).
7. Let *stripPrefix* be **true**.
8. If *R* ≠ 0, then
 - a. If *R* < 2 or *R* > 36, then return **NaN**.
 - b. If *R* ≠ 16, let *stripPrefix* be **false**.
9. Else, *R* = 0
 - a. Let *R* = 10.
10. If *stripPrefix* is **true**, then
 - a. If the length of *S* is at least 2 and the first two characters of *S* are either “**0x**” or “**0X**”, then remove the first two characters from *S* and let *R* = 16.
11. If *S* contains any character that is not a radix-*R* digit, then let *Z* be the substring of *S* consisting of all characters before the first such character; otherwise, let *Z* be *S*.
12. If *Z* is empty, return **NaN**.
13. Let *mathInt* be the mathematical integer value that is represented by *Z* in radix-*R* notation, using the letters **A-Z** and **a-z** for digits with values 10 through 35. (However, if *R* is 10 and *Z* contains more than 20 significant digits, every significant digit after the 20th may be replaced by a **0** digit, at the option of the implementation; and if *R* is not 2, 4, 8, 10, 16, or 32, then *mathInt* may be an implementation-dependent approximation to the mathematical integer value that is represented by *Z* in radix-*R* notation.)
14. Let *number* be the number value for *mathInt*.
15. Return *sign* × *number*.

NOTE

parseInt may interpret only a leading portion of the string as an integer value; it ignores any characters that cannot be interpreted as part of the notation of an integer, and no indication is given that any such characters were ignored.

15.1.2.3 **parseFloat (string)**

The **parseFloat** function produces a number value dictated by interpretation of the contents of the *string* argument as a decimal literal.

When the **parseFloat** function is called, the following steps are taken:

1. Let *inputString* be ToString(*string*).
2. Let *trimmedString* be a substring of *inputString* consisting of the leftmost character that is not a *StrWhiteSpaceChar* and all characters to the right of that character. (In other words, remove leading white space.)
3. If neither *trimmedString* nor any prefix of *trimmedString* satisfies the syntax of a *StrDecimalLiteral* (see 9.3.1), return **NaN**.
4. Let *numberString* be the longest prefix of *trimmedString*, which might be *trimmedString* itself, which satisfies the syntax of a *StrDecimalLiteral*.
5. Return the number value for the MV of *numberString*.

NOTE

parseFloat may interpret only a leading portion of the string as a number value; it ignores any characters that cannot be interpreted as part of the notation of a decimal literal, and no indication is given that any such characters were ignored.

15.1.2.4 isNaN (number)

Returns **true** if the argument coerces to **NaN**, and otherwise returns **false**.

1. If `ToNumber(number)` is **NaN**, return **true**.
2. Otherwise, return **false**.

NOTE

A reliable way to test if a value x is a **NaN** is an expression of the form $x !== x$. The result will be **true** if and only if x is a **NaN**.

15.1.2.5 isFinite (number)

Returns **false** if the argument coerces to **NaN**, $+\infty$, or $-\infty$, and otherwise returns **true**.

1. If `ToNumber(number)` is **NaN**, $+\infty$, or $-\infty$, return **false**.
2. Otherwise, return **true**.

15.1.3 URI Handling Function Properties

Uniform Resource Identifiers, or URIs, are strings that identify resources (e.g. web pages or files) and transport protocols by which to access them (e.g. HTTP or FTP) on the Internet. The ECMAScript language itself does not provide any support for using URIs except for functions that encode and decode URIs as described in 15.1.3.1, 15.1.3.2, 15.1.3.3 and 15.1.3.4.

NOTE

Many implementations of ECMAScript provide additional functions and methods that manipulate web pages; these functions are beyond the scope of this standard.

A URI is composed of a sequence of components separated by component separators. The general form is:

Scheme : First / Second ; Third ? Fourth

where the italicised names represent components and the “:”, “/”, “;” and “?” are reserved characters used as separators. The **encodeURI** and **decodeURI** functions are intended to work with complete URIs; they assume that any reserved characters in the URI are intended to have special meaning and so are not encoded. The **encodeURIComponent** and **decodeURIComponent** functions are intended to work with the individual component parts of a URI; they assume that any reserved characters represent text and so must be encoded so that they are not interpreted as reserved characters when the component is part of a complete URI.

The following lexical grammar specifies the form of encoded URIs.

```
uri :::  
  uriCharactersopt  
  
uriCharacters :::  
  uriCharacter uriCharactersopt  
  
uriCharacter :::  
  uriReserved  
  uriUnescaped  
  uriEscaped  
  
uriReserved ::: one of  
  ; / ? : @ & = + $ ,  
  
uriUnescaped :::  
  uriAlpha  
  DecimalDigit  
  uriMark  
  
uriEscaped :::  
  % HexDigit HexDigit
```

uriAlpha ::: one of

a b c d e f g h i j k l m n o p q r s t u v w x y z
A B C D E F G H I J K L M N O P Q R S T U V W X Y Z

uriMark ::: one of

- _ . ! ~ * ' ()

When a character to be included in a URI is not listed above or is not intended to have the special meaning sometimes given to the reserved characters, that character must be encoded. The character is first transformed into a sequence of octets using the UTF-8 transformation, with surrogate pairs first transformed from their UTF-16 to UTF-32 encodings. (Note that for code units in the range [0,127] this results in a single octet with the same value.) The resulting sequence of octets is then transformed into a string with each octet represented by an escape sequence of the form “%xx”.

The encoding and escaping process is described by the hidden function Encode taking two string arguments *string* and *unescapedSet*. This function is defined for expository purpose only.

1. Let *strLen* be the number of characters in *string*.
2. Let *R* be the empty string.
3. Let *k* be 0.
4. Repeat
 - a. If *k* equals *strLen*, return *R*.
 - b. Let *C* be the character at position *k* within *string*.
 - c. If *C* is in *unescapedSet*, then
 - i. Let *S* be a string containing only the character *C*.
 - ii. Let *R* be a new string value computed by concatenating the previous value of *R* and *S*.
 - d. Else, *C* is not in *unescapedSet*
 - i. If the code unit value of *C* is not less than 0xDC00 and not greater than 0xDFFF, throw a **URIError** exception.
 - ii. If the code unit value of *C* is less than 0xD800 or greater than 0xDBFF, then
 1. Let *V* be the code unit value of *C*.
 - iii. Else,
 1. Increase *k* by 1.
 2. If *k* equals *strLen*, throw a **URIError** exception.
 3. Let *kChar* be the code unit value of the character at position *k* within *string*.
 4. If *kChar* is less than 0xDC00 or greater than 0xDFFF, throw a **URIError** exception.
 5. Let *V* be (((the code unit value of *C*) - 0xD800) * 0x400 + (*kChar* - 0xDC00) + 0x10000).
 - iv. Let *Octets* be the array of octets resulting by applying the UTF-8 transformation to *V*, and let *L* be the array size.
 - v. Let *j* be 0.
 - vi. Repeat, while *j* < *L*
 1. Let *jOctet* be the value at position *j* within *Octets*.
 2. Let *S* be a string containing three characters “%XY” where *XY* are two uppercase hexadecimal digits encoding the value of *jOctet*.
 3. Let *R* be a new string value computed by concatenating the previous value of *R* and *S*.
 4. Increase *j* by 1.
 - e. Increase *k* by 1.

The unescaping and decoding process is described by the hidden function Decode taking two string arguments *string* and *reservedSet*. This function is defined for expository purpose only.

1. Let *strLen* be the number of characters in *string*.
2. Let *R* be the empty string.
3. Let *k* be 0.
4. Repeat
 - a. If *k* equals *strLen*, return *R*.
 - b. Let *C* be the character at position *k* within *string*.
 - c. If *C* is not ‘%’, then

- i. Let *S* be the string containing only the character *C*.
- d. Else, *C* is ‘%’
 - i. Let *start* be *k*.
 - ii. If *k* + 2 is greater than or equal to *strLen*, throw a **URIError** exception.
 - iii. If the characters at position (*k*+1) and (*k* + 2) within *string* do not represent hexadecimal digits, throw a **URIError** exception.
 - iv. Let *B* be the 8-bit value represented by the two hexadecimal digits at position (*k* + 1) and (*k* + 2).
 - v. Increment *k* by 2.
 - vi. If the most significant bit in *B* is 0, then
 1. Let *C* be the character with code unit value *B*.
 2. If *C* is not in *reservedSet*, then
 - a. Let *S* be the string containing only the character *C*.
 3. Else, *C* is in *reservedSet*
 - a. Let *S* be the substring of *string* from position *start* to position *k* included.
 - vii. Else, the most significant bit in *B* is 1
 1. Let *n* be the smallest non-negative number such that (*B* << *n*) & 0x80 is equal to 0.
 2. If *n* equals 1 or *n* is greater than 4, throw a **URIError** exception.
 3. Let *Octets* be an array of 8-bit integers of size *n*.
 4. Put *B* into *Octets* at position 0.
 5. If *k* + (3 * (*n* - 1)) is greater than or equal to *strLen*, throw a **URIError** exception.
 6. Let *j* be 1.
 7. Repeat, while *j* < *n*
 - a. Increment *k* by 1.
 - b. If the character at position *k* is not ‘%’, throw a **URIError** exception.
 - c. If the characters at position (*k* + 1) and (*k* + 2) within *string* do not represent hexadecimal digits, throw a **URIError** exception.
 - d. Let *B* be the 8-bit value represented by the two hexadecimal digits at position (*k* + 1) and (*k* + 2).
 - e. If the two most significant bits in *B* are not 10, throw a **URIError** exception.
 - f. Increment *k* by 2.
 - g. Put *B* into *Octets* at position *j*.
 - h. Increment *j* by 1.
 8. Let *V* be the value obtained by applying the UTF-8 transformation to *Octets*, that is, from an array of octets into a 32-bit value. If *Octets* does not contain a valid UTF-8 encoding of a Unicode code point throw a **URIError** exception.
 9. If *V* is less than 0x10000, then
 - a. Let *C* be the character with code unit value *V*.
 - b. If *C* is not in *reservedSet*, then
 - i. Let *S* be the string containing only the character *C*.
 - c. Else, *C* is in *reservedSet*
 - i. Let *S* be the substring of *string* from position *start* to position *k* included.
 10. Else, *V* is ≥ 0x10000
 - a. If *V* is greater than 0x10FFFF, throw a **URIError** exception.
 - b. Let *L* be (((*V* - 0x10000) & 0x3FF) + 0xDC00).
 - c. Let *H* be ((((*V* - 0x10000) >> 10) & 0x3FF) + 0xD800).
 - d. Let *S* be the string containing the two characters with code unit values *H* and *L*.
 - e. Let *R* be a new string value computed by concatenating the previous value of *R* and *S*.
 - f. Increase *k* by 1.

NOTE

The syntax of Uniform Resource Identifiers is given in RFC 2396.

A formal description and implementation of UTF-8 is given in RFC 3629.

In UTF-8, characters are encoded using sequences of 1 to 6 octets. The only octet of a "sequence" of one has the higher-order bit set to 0, the remaining 7 bits being used to encode the character value. In a sequence of *n* octets, *n*>1, the initial octet has the *n* higher-order bits set to 1, followed by a bit set to 0. The remaining bits of that octet contain bits from the value of the character to be encoded. The following

octets all have the higher-order bit set to 1 and the following bit set to 0, leaving 6 bits in each to contain bits from the character to be encoded. The possible UTF-8 encodings of ECMAScript characters are:

| Code Unit Value | Representation | 1 st Octet | 2 nd Octet | 3 rd Octet | 4 th Octet |
|-----------------------|------------------------|-----------------------|-----------------------|-----------------------|-----------------------|
| 0x0000 - 0x007F | 00000000 0zzzzzzz | 0zzzzzzz | | | |
| 0x0080 - 0x07FF | 00000yyy yyzzzzzz | 110yyyyy | 10zzzzzz | | |
| 0x0800 - 0xD7FF | xxxxyyyy yyzzzzzz | 1110xxxx | 10yyyyyy | 10zzzzzz | |
| 0xD800 - 0xDBFF | 110110vv vvwwwwxx | | | | |
| fb lwed by | fb lwed by | 11110uuu | 10uuwww | 10xyyyyy | 10zzzzzz |
| 0xDC00 - 0xDFFF | 110111yy yyzzzzzz | | | | |
| 0xD800 - 0xDBFF | | | | | |
| not fb lwed by | causes URIError | | | | |
| 0xDC00 - 0xDFFF | | | | | |
| 0xDC00 - 0xDFFF | causes URIError | | | | |
| 0xE000 - 0xFFFF | xxxxyyyy yyzzzzzz | 1110xxxx | 10yyyyyy | 10zzzzzz | |

Where

uuuuu = vvvv + 1

to account for the addition of 0x10000 as in Surrogates, section 3.7, of the Unicode Standard.

The range of code unit values 0xD800-0xDFFF is used to encode surrogate pairs; the above transformation combines a UTF-16 surrogate pair into a UTF-32 representation and encodes the resulting 21-bit value in UTF-8. Decoding reconstructs the surrogate pair.

RFC 3629 prohibits the decoding of invalid UTF-8 octet sequences. For example, the invalid sequence C0 80 must not decode into the character U+0000. Implementations of the Decode algorithm are required to throw a **URIError** when encountering such invalid sequences.

15.1.3.1 decodeURI (encodedURI)

The **decodeURI** function computes a new version of a URI in which each escape sequence and UTF-8 encoding of the sort that might be introduced by the **encodeURI** function is replaced with the character that it represents. Escape sequences that could not have been introduced by **encodeURI** are not replaced.

When the **decodeURI** function is called with one argument *encodedURI*, the following steps are taken:

1. Let *uriString* be ToString(*encodedURI*).
2. Let *reservedURISet* be a string containing one instance of each character valid in *uriReserved* plus “#”.
3. Return the result of calling Decode(*uriString*, *reservedURISet*)

NOTE

The character “#” is not decoded from escape sequences even though it is not a reserved URI character.

15.1.3.2 decodeURIComponent (encodedURIComponent)

The **decodeURIComponent** function computes a new version of a URI in which each escape sequence and UTF-8 encoding of the sort that might be introduced by the **decodeURIComponent** function is replaced with the character that it represents.

When the **decodeURIComponent** function is called with one argument *encodedURIComponent*, the following steps are taken:

1. Let *componentString* be ToString(*encodedURIComponent*).
2. Let *reservedURIComponentSet* be the empty string.
3. Return the result of calling Decode(*componentString*, *reservedURIComponentSet*)

15.1.3.3 **encodeURI (uri)**

The **encodeURI** function computes a new version of a URI in which each instance of certain characters is replaced by one, two or three escape sequences representing the UTF-8 encoding of the character.

When the **encodeURI** function is called with one argument *uri*, the following steps are taken:

1. Let *uriString* be ToString(*uri*).
2. Let *unescapedURISet* be a string containing one instance of each character valid in *uriReserved* and *uriUnescaped* plus “#”.
3. Return the result of calling Encode(*uriString*, *unescapedURISet*)

NOTE

The character “#” is not encoded to an escape sequence even though it is not a reserved or unescaped URI character.

15.1.3.4 **encodeURIComponent (uriComponent)**

The **encodeURIComponent** function computes a new version of a URI in which each instance of certain characters is replaced by one, two or three escape sequences representing the UTF-8 encoding of the character.

When the **encodeURIComponent** function is called with one argument *uriComponent*, the following steps are taken:

1. Let *componentString* be ToString(*uriComponent*).
2. Let *unescapedURIComponentSet* be a string containing one instance of each character valid in *uriUnescaped*.
3. Return the result of calling Encode(*componentString*, *unescapedURIComponentSet*)

15.1.4 **Constructor Properties of the Global Object**

15.1.4.1 **Object (. . .)**

See 15.2.1 and 15.2.2.

15.1.4.2 **Function (. . .)**

See 15.3.1 and 15.3.2.

15.1.4.3 **Array (. . .)**

See 15.4.1 and 15.4.2.

15.1.4.4 **String (. . .)**

See 15.5.1 and 15.5.2.

15.1.4.5 **Boolean (. . .)**

See 15.6.1 and 15.6.2.

15.1.4.6 **Number (. . .)**

See 15.7.1 and 15.7.2.

15.1.4.7 **Date (. . .)**

See 15.9.2.

15.1.4.8 **RegExp (. . .)**

See 15.10.3 and 15.10.4.

15.1.4.9 Error (. . .)

See 15.11.1 and 15.11.2.

15.1.4.10 EvalError (. . .)

See 15.11.6.1.

15.1.4.11 RangeError (. . .)

See 15.11.6.2.

15.1.4.12 ReferenceError (. . .)

See 15.11.6.3.

15.1.4.13 SyntaxError (. . .)

See 15.11.6.4.

15.1.4.14 TypeError (. . .)

See 15.11.6.5.

15.1.4.15 URIError (. . .)

See 15.11.6.6.

15.1.5 Other Properties of the Global Object

15.1.5.1 Math

See 15.8.

15.1.5.2 JSON

See 15.12.

15.2 Object Objects

15.2.1 The Object Constructor Called as a Function

When **Object** is called as a function rather than as a constructor, it performs a type conversion.

15.2.1.1 Object ([value])

When the **Object** function is called with no arguments or with one argument *value*, the following steps are taken:

1. If *value* is **null**, **undefined** or not supplied, create and return a new Object object exactly as if the standard built-in Object constructor had been called with the same arguments (15.2.2.1).
2. Return **ToObject(value)**.

15.2.2 The Object Constructor

When **Object** is called as part of a **new** expression, it is a constructor that may create an object.

15.2.2.1 new Object ([value])

When the **Object** constructor is called with no arguments or with one argument *value*, the following steps are taken:

1. If *value* is supplied, then
 - a. If **Type(value)** is **Object**, then
 - i. If the *value* is a native ECMAScript object, do not create a new object but simply return *value*.
 - ii. If the *value* is a host object, then actions are taken and a result is returned in an implementation-dependent manner that may depend on the host object.
 - b. If **Type(value)** is **String**, return **ToObject(value)**.
 - c. If **Type(value)** is **Boolean**, return **ToObject(value)**.
 - d. If **Type(value)** is **Number**, return **ToObject(value)**.
2. (The argument *value* was not supplied or its type was **Null** or **Undefined**.)
Create a new native ECMAScript object.
The **[[Prototype]]** internal property of the newly constructed object is set to the standard built-in Object prototype object (15.2.4).

The `[[Class]]` internal property of the newly constructed object is set to `"Object"`.

The `[[Extensible]]` internal property of the newly constructed object is set to `true`.

The newly constructed object has all the internal methods as specified in 8.12

3. Return the newly created native object.

15.2.3 Properties of the Object Constructor

The value of the `[[Prototype]]` internal property of the Object constructor is the Function prototype object.

Besides the internal properties and the `length` property (whose value is `1`), the Object constructor has the following properties:

15.2.3.1 Object.prototype

The initial value of `Object.prototype` is the Object prototype object (15.2.4).

This property has the attributes `{[[Writable]]: false, [[Enumerable]]: false, [[Configurable]]: false }`.

15.2.3.2 Object.getPrototypeOf (O)

When the `getPrototypeOf` function is called with argument *O*, the following steps are taken:

1. If `Type(O)` is not `Object` throw a `TypeError` exception.
2. Return the value of the `[[Prototype]]` internal property of *O*.

15.2.3.3 Object.getOwnPropertyDescriptor (O, P)

When the `getOwnPropertyDescriptor` function is called, the following steps are taken:

1. If `Type(O)` is not `Object` throw a `TypeError` exception.
2. Let *name* be `ToString(P)`.
3. Let *desc* be the result of calling the `[[GetOwnProperty]]` internal method of *O* with argument *name*.
4. Return the result of calling `FromPropertyDescriptor(desc)` (8.10.4).

15.2.3.4 Object.getOwnPropertyNames (O)

When the `getOwnPropertyNames` function is called, the following steps are taken:

1. If `Type(O)` is not `Object` throw a `TypeError` exception.
2. Let *array* be the result of creating a new object as if by the expression `new Array ()` where `Array` is the standard built-in constructor with that name.
3. Let *n* be 0.
4. For each named own property *P* of *O*
 - a. Let *name* be the string value that is the name of *P*.
 - b. Call the `[[DefineOwnProperty]]` internal method of *array* with arguments `ToString(n)`, the `PropertyDescriptor` `{[[Value]]: name, [[Writable]]: true, [[Enumerable]]: true, [[Configurable]]: true}`, and `false`.
 - c. Increment *n* by 1.
5. Return *array*.

NOTE

If *O* is a `String` instance, the set of own properties processed in step 4 includes the implicit properties defined in 15.5.5.2 that correspond to character positions within the object's `[[PrimitiveValue]]` string.

15.2.3.5 Object.create (O [, Properties])

The `create` function creates a new object with a specified prototype. When the `create` function is called, the following steps are taken:

1. If `Type(O)` is not `Object` or `Null` throw a `TypeError` exception.
2. Let *obj* be the result of creating a new object as if by the expression `new Object()` where `Object` is the standard built-in constructor with that name
3. Set the `[[Prototype]]` internal property of *obj* to *O*.

4. If the argument *Properties* is present and not **undefined**, add own properties to *obj* as if by calling the standard built-in function **Object.defineProperties** with arguments *obj* and *Properties*.
5. Return *obj*.

15.2.3.6 Object.defineProperty (O, P, Attributes)

The **defineProperty** function is used to add an own property and/or update the attributes of an existing own property of an object. When the **defineProperty** function is called, the following steps are taken:

1. If Type(*O*) is not Object throw a **TypeError** exception.
2. Let *name* be ToString(*P*).
3. Let *desc* be the result of calling ToPropertyDescriptor (section 8.10.5) with *Attributes* as the argument.
4. Call the [[DefineOwnProperty]] internal method of *O* with arguments *name*, *desc*, and **true**.
5. Return *O*.

15.2.3.7 Object.defineProperties (O, Properties)

The **defineProperties** function is used to add own properties and/or update the attributes of existing own properties of an object. When the **defineProperties** function is called, the following steps are taken atomically:

1. If Type(*O*) is not Object throw a **TypeError** exception.
2. Let *props* be ToObject(*Properties*).
3. For each named own enumerable property name *P* of *props*,
 - a. Let *descObj* be the result of calling the [[Get]] internal method of *props* with *P* as the argument.
 - b. Let *desc* be the result of calling ToPropertyDescriptor with *descObj* as the argument.
 - c. Call the [[DefineOwnProperty]] internal method of *O* with arguments *P*, *desc*, and **true**.
4. Return *O*.

The above algorithm is specified as a set of sequential steps that include the possibility of an exception being thrown at various intermediate points. Rather than failing after a partial update of *O*, this function must be implemented such that it either atomically completes all property updates successfully or fails without making any update to the properties of object *O*.

15.2.3.8 Object.seal (O)

When the **seal** function is called, the following steps are taken:

1. If Type(*O*) is not Object throw a **TypeError** exception.
2. For each named own property name *P* of *O*,
 - a. Let *desc* be the result of calling the [[GetOwnProperty]] internal method of *O* with *P*.
 - b. If *desc*.[[Configurable]] is **true**, set *desc*.[[Configurable]] to **false**.
 - c. Call the [[DefineOwnProperty]] internal method of *O* with *P*, *desc*, and **true** as arguments.
3. Set the [[Extensible]] internal property of *O* to **false**.
4. Return *O*.

15.2.3.9 Object.freeze (O)

When the **freeze** function is called, the following steps are taken:

1. If Type(*O*) is not Object throw a **TypeError** exception.
2. For each named own property name *P* of *O*,
 - a. Let *desc* be the result of calling the [[GetOwnProperty]] internal method of *O* with *P*.
 - b. If IsDataDescriptor(*desc*) is **true**, then
 - i. If *desc*.[[Writable]] is **true**, set *desc*.[[Writable]] to **false**.
 - c. If *desc*.[[Configurable]] is **true**, set *desc*.[[Configurable]] to **false**.
 - d. Call the [[DefineOwnProperty]] internal method of *O* with *P*, *desc*, and **true** as arguments.
3. Set the [[Extensible]] internal property of *O* to **false**.
4. Return *O*.

15.2.3.10 **Object.preventExtensions (O)**

When the **preventExtensions** function is called, the following steps are taken:

1. If `Type(O)` is not `Object` throw a **TypeError** exception.
2. Set the `[[Extensible]]` internal property of `O` to **false**.
3. Return `O`.

15.2.3.11 **Object.isSealed (O)**

When the **isSealed** function is called with argument `O`, the following steps are taken:

1. If `Type(O)` is not `Object` throw a **TypeError** exception.
2. For each named own property name `P` of `O`,
 - a. Let `desc` be the result of calling the `[[GetOwnProperty]]` internal method of `O` with `P`.
 - b. If `desc.[[Configurable]]` is **true**, then return **false**.
3. If the `[[Extensible]]` internal property of `O` is **false**, then return **true**.
4. Otherwise, return **false**.

15.2.3.12 **Object.isFrozen (O)**

When the **isFrozen** function is called with argument `O`, the following steps are taken:

1. If `Type(O)` is not `Object` throw a **TypeError** exception.
2. For each named own property name `P` of `O`,
 - a. Let `desc` be the result of calling the `[[GetOwnProperty]]` internal method of `O` with `P`.
 - b. If `IsDataDescriptor(desc)` is **true** then
 - i. If `desc.[[Writable]]` is **true**, return **false**.
 - c. If `desc.[[Configurable]]` is **true**, then return **false**.
3. If the `[[Extensible]]` internal property of `O` is **false**, then return **true**.
4. Otherwise, return **false**.

15.2.3.13 **Object.isExtensible (O)**

When the **isExtensible** function is called with argument `O`, the following steps are taken:

1. If `Type(O)` is not `Object` throw a **TypeError** exception.
2. Return the Boolean value of the `[[Extensible]]` internal property of `O`.

15.2.3.14 **Object.keys (O)**

When the **keys** function is called with argument `O`, the following steps are taken:

1. If the `Type(O)` is not `Object`, throw a **TypeError** exception.
2. Let `n` be the number of own enumerable properties of `O`.
3. Let `array` be the result of creating a new `Object` as if by the expression `new Array(n)` where `Array` is the standard built-in constructor with that name.
4. Let `index` be 0.
5. For each own enumerable property of `O` whose name string is `P`
 - a. Call the `[[DefineOwnProperty]]` internal method of `array` with arguments `ToString(index)`, the `PropertyDescriptor` `{[[Value]]: P, [[Writable]]: true, [[Enumerable]]: true, [[Configurable]]: true}`, and **false**.
 - b. Increment `index` by 1.
6. Return `array`.

If an implementation defines a specific order of enumeration for the for-in statement, that same enumeration order must be used in step 5 of this algorithm.

15.2.4 **Properties of the Object Prototype Object**

The value of the `[[Prototype]]` internal property of the Object prototype object is **null**, the value of the `[[Class]]` internal property is **"Object"**, and the initial value of the `[[Extensible]]` internal property is **true**.

15.2.4.1 **Object.prototype.constructor**

The initial value of `Object.prototype.constructor` is the built-in `Object` constructor.

15.2.4.2 **Object.prototype.toString ()**

When the **toString** method is called, the following steps are taken:

1. Let *O* be the result of calling **ToObject** passing the **this** value as the argument.
2. Let *class* be the value of the **[[Class]]** internal property of *O*.
3. Return the string value that is the result of concatenating the three strings "**[object** ", *class*, and **]**".

15.2.4.3 **Object.prototype.toLocaleString ()**

When the **toLocaleString** method is called, the following steps are taken:

4. Let *O* be the result of calling **ToObject** passing the **this** value as the argument.
5. Let *toString* be the result of calling the **[[Get]]** internal method of *O* passing "**toString**" as the argument.
6. If **IsCallable(*toString*)** is **false**, throw a **TypeError** exception.
7. Return the result of calling the **[[Call]]** internal method of *toString* passing *O* as the **this** value and no arguments.

NOTE

*This function is provided to give all Objects a generic **toLocaleString** interface, even though not all may use it. Currently, **Array**, **Number**, and **Date** provide their own locale-sensitive **toLocaleString** methods.*

The first parameter to this function is likely to be used in a future version of this standard; it is recommended that implementations do not use this parameter position for anything else.

15.2.4.4 **Object.prototype.valueOf ()**

When the **valueOf** method is called, the following steps are taken:

1. Let *O* be the result of calling **ToObject** passing the **this** value as the argument.
2. If *O* is the result of calling the **Object** constructor with a host object (15.2.2.1), then
 - a. Return either *O* or another value such as the host object originally passed to the constructor.
The specific result that is returned is implementation-defined.
3. Return *O*.

15.2.4.5 **Object.prototype.hasOwnProperty (V)**

When the **hasOwnProperty** method is called with argument *V*, the following steps are taken:

1. Let *P* be **ToString(*V*)**.
2. Let *O* be the result of calling **ToObject** passing the **this** value as the argument.
3. Let *desc* be the result of calling the **[[GetOwnProperty]]** internal method of *O* passing *P* as the argument.
4. If *desc* is **undefined**, return **false**.
5. Return **true**.

NOTE

*Unlike **[[HasProperty]]** (8.12.6), this method does not consider objects in the prototype chain.*

*The ordering of steps 1 and 2 is chosen to ensure that any exception that would have been thrown by step 1 in previous editions of this specification will continue to be thrown even if the **this** value is **undefined** or **null**.*

15.2.4.6 **Object.prototype.isPrototypeOf (V)**

When the **isPrototypeOf** method is called with argument *V*, the following steps are taken:

1. If *V* is not an object, return **false**.
2. Let *O* be the result of calling **ToObject** passing the **this** value as the argument.
3. Repeat
 - a. Let *V* be the value of the **[[Prototype]]** internal property of *V*.
 - b. if *V* is **null**, return **false**
 - c. If *O* and *V* refer to the same object, return **true**.

NOTE

The ordering of steps 1 and 2 is chosen to preserve the behaviour specified by previous editions of this specification for the case where V is not an object and the `this` value is undefined or null.

15.2.4.7 **Object.prototype.propertyIsEnumerable (V)**

When the **propertyIsEnumerable** method is called with argument V , the following steps are taken:

1. Let P be ToString(V).
2. Let O be the result of calling ToObject passing the **this** value as the argument.
3. Let $desc$ be the result of calling the `[[GetOwnProperty]]` internal method of O passing P as the argument.
4. If $desc$ is **undefined**, return **false**.
5. Return the value of $desc$.`[[Enumerable]]`.

NOTE

This method does not consider objects in the prototype chain.

*The ordering of steps 1 and 2 is chosen to ensure that any exception that would have been thrown by step 1 in previous editions of this specification will continue to be thrown even if the **this** value is undefined or null.*

15.2.5 **Properties of Object Instances**

Object instances have no special properties beyond those inherited from the Object prototype object.

15.3 **Function Objects**

15.3.1 **The Function Constructor Called as a Function**

When **Function** is called as a function rather than as a constructor, it creates and initialises a new Function object. Thus the function call **Function(...)** is equivalent to the object creation expression **new Function(...)** with the same arguments.

15.3.1.1 **Function (p1, p2, ... , pn, body)**

When the **Function** function is called with some arguments $p1, p2, \dots, pn, body$ (where n might be 0, that is, there are no “ p ” arguments, and where $body$ might also not be provided), the following steps are taken:

1. Create and return a new Function object as if the standard built-in constructor Function was used in a **new** expression with the same arguments (15.3.2.1).

15.3.2 **The Function Constructor**

When **Function** is called as part of a **new** expression, it is a constructor: it initialises the newly created object.

15.3.2.1 **new Function (p1, p2, ... , pn, body)**

The last argument specifies the body (executable code) of a function; any preceding arguments specify formal parameters.

When the **Function** constructor is called with some arguments $p1, p2, \dots, pn, body$ (where n might be 0, that is, there are no “ p ” arguments, and where $body$ might also not be provided), the following steps are taken:

1. Let $argCount$ be the total number of arguments passed to this function invocation.
2. Let P be the empty string.
3. If $argCount = 0$, let $body$ be the empty string.
4. Else if $argCount = 1$, let $body$ be that argument.
5. Else, $argCount > 1$
 - a. Let $firstArg$ be the first argument.
 - b. Let P be ToString($firstArg$).
 - c. Let k be 2.
 - d. Repeat, while $k < argCount$

- i. Let *nextArg* be the k^{th} argument.
 - ii. Let *P* be the result of concatenating the previous value of *P*, the string ", " (a comma), and ToString(*nextArg*).
 - iii. Increase *k* by 1.
 - e. Let *body* be the k^{th} argument.
6. Let *body* be ToString(*body*).
 7. If *P* is not parsable as a *FormalParameterList*_{opt} then throw a **SyntaxError** exception.
 8. If *body* is not parsable as *FunctionBody* then throw a **SyntaxError** exception.
 9. *body* is strict mode code if when it is parsed as a *FunctionBody* the first *SourceElement* within *SourceElements* is a *Statement* production that is an *ExpressionStatement* whose *Expression* consists solely of a *StringLiteral* whose value is a Use Strict Directive (14.1).
 10. If *body* is strict mode code then let *strict* be **true**, else let *strict* be **false**.
 11. If *strict* is **true**, throw any exceptions specified in 13.1 that apply.
 12. Return a new Function object created as specified in 13.2 passing *P* as the *FormalParameterList* and *body* as the *FunctionBody*. Pass in the Global Environment as the *Scope* parameter and *strict* as the *Strict* flag.

A **prototype** property is automatically created for every function, to provide for the possibility that the function will be used as a constructor.

NOTE

It is permissible but not necessary to have one argument for each formal parameter to be specified. For example, all three of the following expressions produce the same result:

```
new Function("a", "b", "c", "return a+b+c")

new Function("a, b, c", "return a+b+c")

new Function("a,b", "c", "return a+b+c")
```

15.3.3 Properties of the Function Constructor

The Function constructor is itself a Function object and its [[Class]] is "**Function**". The value of the [[Prototype]] internal property of the Function constructor is the Function prototype object (15.3.4).

The value of the [[Extensible]] internal property of the Function constructor is **true**.

The Function constructor has the following properties:

15.3.3.1 Function.prototype

The initial value of **Function.prototype** is the Function prototype object (15.3.4).

This property has the attributes { [[Writable]]: **false**, [[Enumerable]]: **false**, [[Configurable]]: **false** }.

15.3.3.2 Function.length

This is a data property with a value of 1. This property has the attributes { [[Writable]]: **false**, [[Enumerable]]: **false**, [[Configurable]]: **false** }.

15.3.4 Properties of the Function Prototype Object

The Function prototype object is itself a Function object (its [[Class]] is "**Function**") that, when invoked, accepts any arguments and returns **undefined**.

The value of the [[Prototype]] internal property of the Function prototype object is the standard built-in Object prototype object (15.2.4). The initial value of the [[Extensible]] internal property of the Function prototype object is **true**.

The Function prototype object does not have a **valueOf** property of its own; however, it inherits the **valueOf** property from the Object prototype Object.

The **length** property of the Function prototype object is **0**.

15.3.4.1 Function.prototype.constructor

The initial value of **Function.prototype.constructor** is the built-in **Function** constructor.

15.3.4.2 **Function.prototype.toString ()**

An implementation-dependent representation of the function is returned. This representation has the syntax of a *FunctionDeclaration*. Note in particular that the use and placement of white space, line terminators, and semicolons within the representation string is implementation-dependent.

The **toString** function is not generic; it throws a **TypeError** exception if its **this** value is not a Function object. Therefore, it cannot be transferred to other kinds of objects for use as a method.

15.3.4.3 **Function.prototype.apply (thisArg, argArray)**

When the **apply** method is called on an object *func* with arguments *thisArg* and *argArray*, the following steps are taken:

1. If **IsCallable**(*func*) is **false**, then throw a **TypeError** exception.
2. If *argArray* is **null** or **undefined**, then
 - a. Return the result of calling the **[[Call]]** internal method of *func*, providing *thisArg* as the **this** value and an empty list of arguments.
3. If **Type**(*argArray*) is not **Object**, then throw a **TypeError** exception.
4. Let *len* be the result of calling the **[[Get]]** internal method of *argArray* with argument **"length"**.
5. If *len* is **null** or **undefined**, then throw a **TypeError** exception.
6. Let *n* be **ToUint32**(*len*).
7. If *n* is not equal to **ToNumber**(*len*), then throw a **TypeError** exception.
8. Let *argList* be an empty List.
9. Let *index* be 0.
10. Repeat while *index* < *n*
 - a. Let *indexName* be **ToString**(*index*).
 - b. Let *nextArg* be the result of calling the **[[Get]]** internal method of *argArray* with *indexName* as the argument.
 - c. Append *nextArg* as the last element of *argList*.
 - d. Set *index* to *index* + 1.
11. Return the result of calling the **[[Call]]** internal method of *func*, providing *thisArg* as the **this** value and *argList* as the list of arguments.

The **length** property of the **apply** method is **2**.

NOTE

The *thisArg* value is passed without modification as the **this** value. This is a change from Edition 3, where a **undefined** or **null** *thisArg* is replaced with the global object and **ToObject** is applied to all other values and that result is passed as the **this** value.

15.3.4.4 **Function.prototype.call (thisArg [, arg1 [, arg2, ...]])**

When the **call** method is called on an object *func* with argument *thisArg* and optional arguments *arg1*, *arg2* etc, the following steps are taken:

1. If **IsCallable**(*func*) is **false**, then throw a **TypeError** exception.
2. Let *argList* be an empty List.
3. If this method was called with more than one argument then in left to right order starting with *arg1* append each argument as the last element of *argList*
4. Return the result of calling the **[[Call]]** internal method of *func*, providing *thisArg* as the **this** value and *argList* as the list of arguments.

The **length** property of the **call** method is **1**.

NOTE

The *thisArg* value is passed without modification as the **this** value. This is a change from Edition 3, where a **undefined** or **null** *thisArg* is replaced with the global object and **ToObject** is applied to all other values and that result is passed as the **this** value.

15.3.4.5 **Function.prototype.bind (thisArg [, arg1 [, arg2, ...]])**

The **bind** method takes one or more arguments, *thisArg* and (optionally) *arg1*, *arg2*, etc, and returns a new function object by performing the following steps:

1. Let *Target* be the **this** value.
2. If `IsCallable(Target)` is **false**, throw a **TypeError** exception.
3. Let *A* be a new (possibly empty) internal list of all of the argument values provided after *thisArg* (*arg1*, *arg2* etc), in order.
4. Let *F* be a new native ECMAScript object .
5. Set the `[[TargetFunction]]` internal property of *F* to *Target*.
6. Set the `[[BoundThis]]` internal property of *F* to the value of *thisArg*.
7. Set the `[[BoundArgs]]` internal property of *F* to *A*.
8. Set the `[[Class]]` internal property of *F* to **"Function"**.
9. Set the `[[Prototype]]` internal property of *F* to the standard built-in Function prototype object as specified in 15.3.3.1.
10. Set the `[[Call]]` internal property of *F* as described in 15.3.4.5.1.
11. Set the `[[Construct]]` internal property of *F* as described in 15.3.4.5.2.
12. Set the `[[HasInstance]]` internal property of *F* as described in 15.3.4.5.3.
13. If the `[[Class]]` internal property of *Target* is **"Function"**, then
 - a. Let *L* be the **length** property of *Target* minus the length of *A*.
 - b. Set the **length** own property of *F* to either 0 or *L*, whichever is larger.
14. Else set the **length** own property of *F* to 0.
15. Set the attributes of the **length** own property of *F* to the values specified in 15.3.5.1.
16. Set the `[[Extensible]]` internal property of *F* to **true**.
17. Let *thrower* be the `[[ThrowTypeError]]` function Object (13.2.3).
18. Call the `[[DefineOwnProperty]]` internal method of *F* with arguments **"caller"**, PropertyDescriptor `{[[Get]]: thrower, [[Set]]: thrower, [[Enumerable]]: false, [[Configurable]]: false}`, and **false**.
19. Call the `[[DefineOwnProperty]]` internal method of *F* with arguments **"arguments"**, PropertyDescriptor `{[[Get]]: thrower, [[Set]]: thrower, [[Enumerable]]: false, [[Configurable]]: false}`, and **false**.
20. Return *F*.

The **length** property of the **bind** method is **1**.

NOTE

Function objects created using `Function.prototype.bind` do not have a **prototype** property or a `[[Scope]]` internal property.

15.3.4.5.1 `[[Call]]`

When the `[[Call]]` internal method of a function object, *F*, which was created using the `bind` function is called with a **this** value and a list of arguments *ExtraArgs*, the following steps are taken:

1. Let *boundArgs* be the value of *F*'s `[[BoundArgs]]` internal property.
2. Let *boundThis* be the value of *F*'s `[[BoundThis]]` internal property.
3. Let *target* be the value of *F*'s `[[TargetFunction]]` internal property.
4. Let *args* be a new list containing the same values as the list *boundArgs* in the same order followed by the same values as the list *ExtraArgs* in the same order.
5. Return the result of calling the `[[Call]]` internal method of *target* providing *boundThis* as the **this** value and providing *args* as the arguments.

15.3.4.5.2 `[[Construct]]`

When the `[[Construct]]` internal method of a function object, *F* that was created using the `bind` function is called with a list of arguments *ExtraArgs*, the following steps are taken:

1. Let *target* be the value of *F*'s `[[TargetFunction]]` internal property.
2. If *target* has no `[[Construct]]` internal method, a **TypeError** exception is thrown.
3. Let *boundArgs* be the value of *F*'s `[[BoundArgs]]` internal property.
4. Let *args* be a new list containing the same values as the list *boundArgs* in the same order followed by the same values as the list *ExtraArgs* in the same order.
5. Return the result of calling the `[[Construct]]` internal method of *target* providing *args* as the arguments.

15.3.4.5.3 `[[HasInstance]]` (V)

When the `[[HasInstance]]` internal method of a function object F , that was created using the `bind` function is called with argument V , the following steps are taken:

1. Let $target$ be the value of F 's `[[TargetFunction]]` internal property.
2. If $target$ has no `[[HasInstance]]` internal method, a **TypeError** exception is thrown.
3. Return the result of calling the `[[HasInstance]]` internal method of $target$ providing V as the argument.

15.3.5 Properties of Function Instances

In addition to the required internal properties, every function instance has a `[[Call]]` internal property and in most cases use a different version of the `[[Get]]` internal property. Depending on how they are created (see 8.6.2, 13.2, 15, and 15.3.4.5), function instances may have a `[[HasInstance]]` internal property, a `[[Scope]]` internal property, a `[[Construct]]` internal property, a `[[FormalParameters]]` internal property, a `[[Code]]` internal property, a `[[TargetFunction]]` internal property, a `[[BoundThis]]` internal property, and a `[[BoundArgs]]` internal property.

The value of the `[[Class]]` internal property is **"Function"**.

Function instances that correspond to strict mode functions (13.2) and function instances created using the **Function.prototype.bind method** (15.3.4.5) have properties named "caller" and "arguments" that throw a **TypeError** exception. An ECMAScript implementation must not associate any implementation specific behaviour with accesses of these properties from strict mode function code.

15.3.5.1 **length**

The value of the **length** property is an integer that indicates the "typical" number of arguments expected by the function. However, the language permits the function to be invoked with some other number of arguments. The behaviour of a function when invoked on a number of arguments other than the number specified by its **length** property depends on the function. This property has the attributes { `[[Writable]]`: **false**, `[[Enumerable]]`: **false**, `[[Configurable]]`: **false** }.

15.3.5.2 **prototype**

The value of the **prototype** property is used to initialise the `[[Prototype]]` internal property of a newly created object before the Function object is invoked as a constructor for that newly created object. This property has the attribute { `[[Writable]]`: **true**, `[[Enumerable]]`: **false**, `[[Configurable]]`: **false** }.

NOTE

*Function objects created using **Function.prototype.bind** do not have a **prototype** property.*

15.3.5.3 `[[HasInstance]]` (V)

Assume F is a Function object.

When the `[[HasInstance]]` internal method of F is called with value V , the following steps are taken:

1. If V is not an object, return **false**.
2. Let O be the result of calling the `[[Get]]` internal method of F with property name **"prototype"**.
3. If O is not an object, throw a **TypeError** exception.
4. Repeat
 - a. Let V be the value of the `[[Prototype]]` internal property of V .
 - b. If V is **null**, return **false**.
 - c. If O and V refer to the same object, return **true**.

NOTE

*Function objects created using **Function.prototype.bind** have a different implementation of `[[HasInstance]]` defined in 15.3.4.5.3.*

15.3.5.4 `[[Get]]` (P)

Function objects use a variation of the `[[Get]]` internal method used for other native ECMAScript objects (8.12.3).

Assume F is a Function object. When the `[[Get]]` internal method of F is called with property name P , the following steps are taken:

1. Let v be the result of calling the default `[[Get]]` internal method (8.12.3) on F passing P as the property name argument.
2. If P is **"caller"** and v is a strict mode Function object, throw a **TypeError** exception.
3. Return v .

NOTE

Function objects created using `Function.prototype.bind` use the default `[[Get]]` internal method.

15.4 Array Objects

Array objects give special treatment to a certain class of property names. A property name P (in the form of a string value) is an *array index* if and only if `ToString(ToUint32(P))` is equal to P and `ToUint32(P)` is not equal to $2^{32}-1$. A property whose property name is an array index is also called an *element*. Every Array object has a **length** property whose value is always a nonnegative integer less than 2^{32} . The value of the **length** property is numerically greater than the name of every property whose name is an array index; whenever a property of an Array object is created or changed, other properties are adjusted as necessary to maintain this invariant. Specifically, whenever a property is added whose name is an array index, the **length** property is changed, if necessary, to be one more than the numeric value of that array index; and whenever the **length** property is changed, every property whose name is an array index whose value is not smaller than the new length is automatically deleted. This constraint applies only to own properties of an Array object and is unaffected by **length** or array index properties that may be inherited from its prototypes.

An object, O , is said to be *sparse* if the following algorithm returns **true**:

1. Let *lenDesc* be the result of calling the `[[GetOwnProperty]]` internal method of O with argument **"length"**.
2. If *lenDesc* is **undefined**, return **false**.
3. Let *len* be the result of calling the `[[Get]]` internal method of O with argument **"length"**.
4. For each integer i in the range $0 \leq i < \text{ToUint32}(\text{len})$
 - a. Let *elem* be the result of calling the `[[GetOwnProperty]]` internal method of O with argument `ToString(i)`.
 - b. If *lenDesc* is **undefined**, return **false**.
5. Return **true**.

15.4.1 The Array Constructor Called as a Function

When **Array** is called as a function rather than as a constructor, it creates and initialises a new Array object. Thus the function call **Array(...)** is equivalent to the object creation expression **new Array(...)** with the same arguments.

15.4.1.1 `Array` ([item1 [, item2 [, ...]]])

When the **Array** function is called the following steps are taken:

1. Create and return a new Array object exactly as if the standard built-in constructor **Array** was used in a **new** expression with the same arguments (15.4.2).

15.4.2 The Array Constructor

When **Array** is called as part of a **new** expression, it is a constructor: it initialises the newly created object.

15.4.2.1 `new Array` ([item0 [, item1 [, ...]]])

This description applies if and only if the Array constructor is given no arguments or at least two arguments.

The `[[Prototype]]` internal property of the newly constructed object is set to the original Array prototype object, the one that is the initial value of `Array.prototype` (15.4.3.1).

The `[[Class]]` internal property of the newly constructed object is set to `"Array"`.

The `[[Extensible]]` internal property of the newly constructed object is set to `true`.

The `length` property of the newly constructed object is set to the number of arguments.

The `0` property of the newly constructed object is set to `item0` (if supplied); the `1` property of the newly constructed object is set to `item1` (if supplied); and, in general, for as many arguments as there are, the `k` property of the newly constructed object is set to argument `k`, where the first argument is considered to be argument number `0`. These properties all have the attributes `[[Writable]]: true`, `[[Enumerable]]: true`, `[[Configurable]]: true`.

15.4.2.2 `new Array (len)`

The `[[Prototype]]` internal property of the newly constructed object is set to the original Array prototype object, the one that is the initial value of `Array.prototype` (15.4.3.1). The `[[Class]]` internal property of the newly constructed object is set to `"Array"`. The `[[Extensible]]` internal property of the newly constructed object is set to `true`.

If the argument `len` is a Number and `ToUint32(len)` is equal to `len`, then the `length` property of the newly constructed object is set to `ToUint32(len)`. If the argument `len` is a Number and `ToUint32(len)` is not equal to `len`, a `RangeError` exception is thrown.

If the argument `len` is not a Number, then the `length` property of the newly constructed object is set to `1` and the `0` property of the newly constructed object is set to `len` with attributes `[[Writable]]: true`, `[[Enumerable]]: true`, `[[Configurable]]: true`..

15.4.3 Properties of the Array Constructor

The value of the `[[Prototype]]` internal property of the Array constructor is the Function prototype object (15.3.4).

Besides the internal properties and the `length` property (whose value is `1`), the Array constructor has the following properties:

15.4.3.1 `Array.prototype`

The initial value of `Array.prototype` is the Array prototype object (15.4.4).

This property has the attributes `{ [[Writable]]: false, [[Enumerable]]: false, [[Configurable]]: false }`.

15.4.3.2 `Array.isArray (arg)`

The `isArray` function takes one argument `arg`, and returns the Boolean value `true` if the argument is an object whose class internal property is `"Array"`; otherwise it returns `false`. The following steps are taken:

1. If `Type(arg)` is not `Object`, return `false`.
2. If the value of the `[[Class]]` internal property of `arg` is `"Array"`, then return `true`.
3. Return `false`.

15.4.4 Properties of the Array Prototype Object

The value of the `[[Prototype]]` internal property of the Array prototype object is the standard built-in Object prototype object (15.2.4).

The Array prototype object is itself an array; its `[[Class]]` is `"Array"`, and it has a `length` property (whose initial value is `+0`) and the special `[[DefineOwnProperty]]` internal method described in 15.4.5.1.

In following descriptions of functions that are properties of the Array prototype object, the phrase “this object” refers to the object that is the `this` value for the invocation of the function. It is permitted for the `this` to be an object for which the value of the `[[Class]]` internal property is not `"Array"`.

NOTE

The `Array` prototype object does not have a `valueOf` property of its own; however, it inherits the `valueOf` property from the `Object` prototype Object.

15.4.4.1 `Array.prototype.constructor`

The initial value of `Array.prototype.constructor` is the built-in `Array` constructor.

15.4.4.2 `Array.prototype.toString` ()

When the `toString` method is called, the following steps are taken:

1. Let *array* be the result of calling `ToObject` on the **this** value.
2. Let *func* be the result of calling the `[[Get]]` internal method of *array* with argument `"join"`.
3. If `IsCallable(func)` is **false**, then let *func* be the standard built-in method `Object.prototype.toString` (15.2.4.2).
4. Return the result of calling the `[[Call]]` internal method of *func* providing *array* as the **this** value and an empty arguments list.

NOTE

The `toString` function is intentionally generic; it does not require that its **this** value be an `Array` object. Therefore it can be transferred to other kinds of objects for use as a method. Whether the `toString` function can be applied successfully to a host object is implementation-dependent.

15.4.4.3 `Array.prototype.toLocaleString` ()

The elements of the array are converted to strings using their `toLocaleString` methods, and these strings are then concatenated, separated by occurrences of a separator string that has been derived in an implementation-defined locale-specific way. The result of calling this function is intended to be analogous to the result of `toString`, except that the result of this function is intended to be locale-specific.

The result is calculated as follows:

1. Let *O* be the result of calling `ToObject` passing the **this** value as the argument.
2. Let *arrayLen* be the result of calling the `[[Get]]` internal method of *array* with argument `"length"`.
3. Let *len* be `ToUint32(arrayLen)`.
4. Let *separator* be the `String` value for the list-separator string appropriate for the host environment's current locale (this is derived in an implementation-defined way).
5. If *len* is zero, return the empty string.
6. Let *firstElement* be the result of calling the `[[Get]]` internal method of *array* with argument `"0"`.
7. If *firstElement* is **undefined** or **null**, then
 - a. Let *R* be the empty string.
8. Else
 - a. Let *elementObj* be `ToObject(firstElement)`.
 - b. Let *func* be the result of calling the `[[Get]]` internal method of *elementObj* with argument `"toLocaleString"`.
 - c. If `IsCallable(func)` is **false**, throw a **TypeError** exception.
 - d. Let *R* be the result of calling the `[[Call]]` internal method of *func* providing *elementObj* as the **this** value and an empty arguments list.
9. Let *k* be 1.
10. Repeat, while *k* < *len*
 - a. Let *S* be a string value produced by concatenating *R* and *separator*.
 - b. Let *nextElement* be the result of calling the `[[Get]]` internal method of *array* with argument `ToString(k)`.
 - c. If *nextElement* is **undefined** or **null**, then
 - i. Let *R* be the empty string.
 - d. Else
 - i. Let *elementObj* be `ToObject(nextElement)`.
 - ii. Let *func* be the result of calling the `[[Get]]` internal method of *elementObj* with argument `"toLocaleString"`.

- iii. If `IsCallable(func)` is **false**, throw a **TypeError** exception.
 - iv. Let *R* be the result of calling the `[[Call]]` internal method of *func* providing *elementObj* as the **this** value and an empty arguments list.
 - e. Let *R* be a string value produced by concatenating *S* and *R*.
 - f. Increase *k* by 1.
11. Return *R*.

NOTE

The first parameter to this function is likely to be used in a future version of this standard; it is recommended that implementations do not use this parameter position for anything else.

The `toLocaleString` function is intentionally generic; it does not require that its **this** value be an Array object. Therefore it can be transferred to other kinds of objects for use as a method. Whether the `toLocaleString` function can be applied successfully to a host object is implementation-dependent.

15.4.4.4 `Array.prototype.concat` ([*item1* [, *item2* [, ...]]])

When the `concat` method is called with zero or more arguments *item1*, *item2*, etc., it returns an array containing the array elements of the object followed by the array elements of each argument in order.

The following steps are taken:

1. Let *O* be the result of calling `ToObject` passing the **this** value as the argument.
2. Let *A* be a new array created as if by the expression `new Array()` where `Array` is the standard built-in constructor with that name.
3. Let *n* be 0.
4. Let *items* be an internal List whose first element is *O* and whose subsequent elements are, in left to right order, the arguments that were passed to this function invocation.
5. Repeat, while *items* is not empty
 - a. Remove the first element from *items* and let *E* be the value of the element.
 - b. If the value of the `[[Class]]` internal property of *E* is **"Array"**, then
 - i. Let *k* be 0.
 - ii. Let *len* be the result of calling the `[[Get]]` internal method of *E* with argument **"length"**.
 - iii. Repeat, while *k* < *len*
 1. Let *P* be `Tostring(k)`.
 2. Let *exists* be the result of calling the `[[HasProperty]]` internal method of *E* with *P*.
 3. If *exists* is **true**, then
 - a. Let *subElement* be the result of calling the `[[Get]]` internal method of *E* with argument *P*.
 - b. Call the `[[DefineOwnProperty]]` internal method of *A* with arguments `Tostring(n)`, Property Descriptor `{[[Value]]: subElement, [[Writable]]: true, [[Enumerable]]: true, [[Configurable]]: true}`, and **false**.
 4. Increase *n* by 1.
 5. Increase *k* by 1.
 - c. Else, *E* is not an Array
 - i. Call the `[[DefineOwnProperty]]` internal method of *A* with arguments `Tostring(n)`, Property Descriptor `{[[Value]]: E, [[Writable]]: true, [[Enumerable]]: true, [[Configurable]]: true}`, and **false**.
 - ii. Increase *n* by 1.
6. Return *A*.

The `length` property of the `concat` method is **1**.

NOTE

The `concat` function is intentionally generic; it does not require that its **this** value be an Array object. Therefore it can be transferred to other kinds of objects for use as a method. Whether the `concat` function can be applied successfully to a host object is implementation-dependent.

15.4.4.5 **Array.prototype.join (separator)**

The elements of the array are converted to strings, and these strings are then concatenated, separated by occurrences of the *separator*. If no separator is provided, a single comma is used as the separator.

The **join** method takes one argument, *separator*, and performs the following steps:

1. Let *O* be the result of calling **ToObject** passing the **this** value as the argument.
2. Let *lenVal* be the result of calling the **[[Get]]** internal method of *O* with argument **"length"**.
3. Let *len* be **ToUint32(lenVal)**.
4. If *separator* is **undefined**, let *separator* be the single-character string **" , "**.
5. Let *sep* be **ToString(separator)**.
6. If *len* is zero, return the empty string.
7. Let *element0* be the result of calling the **[[Get]]** internal method of *O* with argument **"0"**.
8. If *element0* is **undefined** or **null**, let *R* be the empty string; otherwise, Let *R* be **ToString(element0)**.
9. Let *k* be **1**.
10. Repeat, while *k* < *len*
 - a. Let *S* be the string value produced by concatenating *R* and *sep*.
 - b. Let *element* be the result of calling the **[[Get]]** internal method of *O* with argument **ToString(k)**.
 - c. If *element* is **undefined** or **null**, Let *next* be the empty string; otherwise, let *next* be **ToString(element)**.
 - d. Let *R* be a string value produced by concatenating *S* and *next*.
 - e. Increase *k* by 1.
11. Return *R*.

The **length** property of the **join** method is **1**.

NOTE

*The **join** function is intentionally generic; it does not require that its **this** value be an Array object. Therefore, it can be transferred to other kinds of objects for use as a method. Whether the **join** function can be applied successfully to a host object is implementation-dependent.*

15.4.4.6 **Array.prototype.pop ()**

The last element of the array is removed from the array and returned.

1. Let *O* be the result of calling **ToObject** passing the **this** value as the argument.
2. Let *lenVal* be the result of calling the **[[Get]]** internal method of *O* with argument **"length"**.
3. Let *len* be **ToUint32(lenVal)**.
4. If *len* is zero,
 - a. Call the **[[Put]]** internal method of *O* with arguments **"length"**, **0**, and **true**.
 - b. Return **undefined**.
5. Else, *len* > 0
 - a. Let *indx* be **ToString(len-1)**.
 - b. Let *element* be the result of calling the **[[Get]]** internal method of *O* with argument *indx*.
 - c. Call the **[[Delete]]** internal method of *O* with arguments *indx* and **true**.
 - d. Call the **[[Put]]** internal method of *O* with arguments **"length"**, *indx*, and **true**.
 - e. Return *element*.

NOTE

*The **pop** function is intentionally generic; it does not require that its **this** value be an Array object. Therefore it can be transferred to other kinds of objects for use as a method. Whether the **pop** function can be applied successfully to a host object is implementation-dependent.*

15.4.4.7 **Array.prototype.push ([item1 [, item2 [, ...]]])**

The arguments are appended to the end of the array, in the order in which they appear. The new length of the array is returned as the result of the call.

When the **push** method is called with zero or more arguments *item1*, *item2*, etc., the following steps are taken:

1. Let *O* be the result of calling `ToObject` passing the **this** value as the argument.
2. Let *lenVal* be the result of calling the `[[Get]]` internal method of *O* with argument "**length**".
3. Let *n* be `ToUint32(lenVal)`.
4. Let *items* be an internal List whose elements are, in left to right order, the arguments that were passed to this function invocation.
5. Repeat, while *items* is not empty
 - a. Remove the first element from *items* and let *E* be the value of the element.
 - b. Call the `[[Put]]` internal method of *O* with arguments `Tostring(n)`, *E*, and **true**.
 - c. Increase *n* by 1.
6. Call the `[[Put]]` internal method of *O* with arguments "**length**", *n*, and **true**.
7. Return *n*.

The **length** property of the **push** method is **1**.

NOTE

The **push** function is intentionally generic; it does not require that its **this** value be an Array object. Therefore it can be transferred to other kinds of objects for use as a method. Whether the **push** function can be applied successfully to a host object is implementation-dependent.

15.4.4.8 **Array.prototype.reverse** ()

The elements of the array are rearranged so as to reverse their order. The object is returned as the result of the call.

1. Let *O* be the result of calling `ToObject` passing the **this** value as the argument.
2. Let *lenVal* be the result of calling the `[[Get]]` internal method of *O* with argument "**length**".
3. Let *len* be `ToUint32(lenVal)`.
4. Let *middle* be `floor(len/2)`.
5. Let *lower* be **0**.
6. Repeat, while *lower* \neq *middle*
 - a. Let *upper* be *len* - *lower* - 1.
 - b. Let *upperP* be `Tostring(upper)`.
 - c. Let *lowerP* be `Tostring(lower)`.
 - d. Let *lowerValue* be the result of calling the `[[Get]]` internal method of *O* with argument *lowerP*.
 - e. Let *upperValue* be the result of calling the `[[Get]]` internal method of *O* with argument *upperP*.
 - f. Let *lowerExists* be the result of calling the `[[HasProperty]]` internal method of *O* with argument *lowerP*.
 - g. Let *upperExists* be the result of calling the `[[HasProperty]]` internal method of *O* with argument *upperP*.
 - h. If *lowerExists* is **true** and *upperExists* is **true**, then
 - i. Call the `[[Put]]` internal method of *O* with arguments *lowerP*, *upperValue*, and **true**.
 - ii. Call the `[[Put]]` internal method of *O* with arguments *upperP*, *lowerValue*, and **true**.
 - i. Else if *lowerExists* is **false** and *upperExists* is **true**, then
 - i. Call the `[[Put]]` internal method of *O* with arguments *lowerP*, *upperValue*, and **true**.
 - ii. Call the `[[Delete]]` internal method of *O*, with arguments *upperP* and **true**.
 - j. Else if *lowerExists* is **true** and *upperExists* is **false**, then
 - i. Call the `[[Delete]]` internal method of *O*, with arguments *lowerP* and **true**.
 - ii. Call the `[[Put]]` internal method of *O* with arguments *upperP*, *lowerValue*, and **true**.
 - k. Else, both *lowerExists* and *upperExists* are **false**
 - i. No action is required.
 - l. Increase *lower* by 1.
7. Return *O*.

NOTE

The **reverse** function is intentionally generic; it does not require that its **this** value be an Array object. Therefore, it can be transferred to other kinds of objects for use as a method. Whether the **reverse** function can be applied successfully to a host object is implementation-dependent.

15.4.4.9 Array.prototype.shift ()

The first element of the array is removed from the array and returned.

1. Let *O* be the result of calling ToObject passing the **this** value as the argument.
2. Let *lenVal* be the result of calling the [[Get]] internal method of *O* with argument "length".
3. Let *len* be ToUint32(*lenVal*).
4. If *len* is zero, then
 - a. Call the [[Put]] internal method of *O* with arguments "length", 0, and **true**.
 - b. Return **undefined**.
5. Let *first* be the result of calling the [[Get]] internal method of *O* with argument "0".
6. Let *k* be 1.
7. Repeat, while *k* < *len*
 - a. Let *from* be ToString(*k*).
 - b. Let *to* be ToString(*k*-1).
 - c. Let *fromPresent* be the result of calling the [[HasProperty]] internal method of *O* with argument *from*.
 - d. If *fromPresent* is **true**, then
 - i. Let *fromVal* be the result of calling the [[Get]] internal method of *O* with argument *from*.
 - ii. Call the [[Put]] internal method of *O* with arguments *to*, *fromVal*, and **true**.
 - e. Else, *fromPresent* is **false**
 - i. Call the [[Delete]] internal method of *O* with arguments *to* and **true**.
 - f. Increase *k* by 1.
8. Call the [[Delete]] internal method of *O* with arguments ToString(*len*-1) and **true**.
9. Call the [[Put]] internal method of *O* with arguments "length", (*len*-1), and **true**.
10. Return *first*.

NOTE

The **shift** function is intentionally generic; it does not require that its **this** value be an Array object. Therefore it can be transferred to other kinds of objects for use as a method. Whether the **shift** function can be applied successfully to a host object is implementation-dependent.

15.4.4.10 Array.prototype.slice (start, end)

The **slice** method takes two arguments, *start* and *end*, and returns an array containing the elements of the array from element *start* up to, but not including, element *end* (or through the end of the array if *end* is **undefined**). If *start* is negative, it is treated as (*length*+*start*) where *length* is the length of the array. If *end* is negative, it is treated as (*length*+*end*) where *length* is the length of the array. The following steps are taken:

1. Let *O* be the result of calling ToObject passing the **this** value as the argument.
2. Let *A* be a new array created as if by the expression **new Array()** where **Array** is the standard built-in constructor with that name.
3. Let *lenVal* be the result of calling the [[Get]] internal method of *O* with argument "length".
4. Let *len* be ToUint32(*lenVal*).
5. Let *relativeStart* be ToInteger(*start*).
6. If *relativeStart* is negative, let *k* be max((*len* + *relativeStart*),0); else let *k* be min(*relativeStart*, *len*).
7. If *end* is **undefined**, let *relativeEnd* be *len*; else let *relativeEnd* be ToInteger(*end*).
8. If *relativeEnd* is negative, let *final* be max((*len* + *relativeEnd*),0); else let *final* be min(*relativeEnd*, *len*).
9. Let *n* be 0.
10. Repeat, while *k* < *final*
 - a. Let *Pk* be ToString(*k*).

- b. Let *kPresent* be the result of calling the `[[HasProperty]]` internal method of *O* with argument *Pk*.
 - c. If *kPresent* is **true**, then
 - i. Let *kValue* be the result of calling the `[[Get]]` internal method of *O* with argument *Pk*.
 - ii. Call the `[[DefineOwnProperty]]` internal method of *A* with arguments `ToString(n)`, Property Descriptor `{[[Value]]: kValue, [[Writable]]: true, [[Enumerable]]: true, [[Configurable]]: true}`, and **false**.
 - d. Increase *k* by 1.
 - e. Increase *n* by 1.
11. Return *A*.

The **length** property of the **slice** method is **2**.

NOTE

The **slice** function is intentionally generic; it does not require that its **this** value be an Array object. Therefore it can be transferred to other kinds of objects for use as a method. Whether the **slice** function can be applied successfully to a host object is implementation-dependent.

15.4.4.11 Array.prototype.sort (comparefn)

The elements of this array are sorted. The sort is not necessarily stable (that is, elements that compare equal do not necessarily remain in their original order). If *comparefn* is not **undefined**, it should be a function that accepts two arguments *x* and *y* and returns a negative value if *x* < *y*, zero if *x* = *y*, or a positive value if *x* > *y*.

Let *obj* be the result of calling `ToObject` passing the **this** value as the argument.

Let *len* be the result applying `Uint32` to the result of calling the `[[Get]]` internal method of *obj* with argument **"length"**.

If *comparefn* is not **undefined** and is not a consistent comparison function for the elements of this array (see below), the behaviour of **sort** is implementation-defined.

Let *proto* be the value of the `[[Prototype]]` internal property of *obj*. If *proto* is not **null** and there exists an integer *j* such that all of the conditions below are satisfied then the behaviour of **sort** is implementation-defined:

- *obj* is sparse (15.4)
- $0 \leq j < len$
- The result of calling the `[[HasOwnProperty]]` internal method of *proto* with argument `ToString(j)` is **true**.

The behaviour of **sort** is also implementation defined if *obj* is sparse and any of the following conditions are true:

- The `[[Extensible]]` internal property of *obj* is **false**.
- Any array index property of *obj* whose name is a nonnegative integer less than *len* is a data property whose `[[Writable]]` attribute is **false** or whose `[[Configurable]]` attribute is **false**.

The behaviour of **sort** is also implementation defined if any array index property of *obj* whose name is a nonnegative integer less than *len* is an accessor property.

Otherwise, the following steps are taken.

1. Perform an implementation-dependent sequence of calls to the `[[Get]]`, `[[Put]]`, and `[[Delete]]` internal methods of *obj* and to `SortCompare` (described below), where the first argument for each call to `[[Get]]`, `[[Put]]`, or `[[Delete]]` is a nonnegative integer less than *len* and where the arguments for calls to `SortCompare` are results of previous calls to the `[[Get]]` internal method. The throw argument to the `[[Put]]` and `[[Delete]]` internal methods will be the value **true**. If *obj* is sparse then `[[Delete]]` must not be called.
2. Return *obj*.

The returned object must have the following two properties.

- There must be some mathematical permutation π of the nonnegative integers less than len , such that for every nonnegative integer j less than len , if property `old[j]` existed, then `new[$\pi(j)$]` is exactly the same value as `old[j]`. But if property `old[j]` did not exist, then `new[$\pi(j)$]` does not exist.
- Then for all nonnegative integers j and k , each less than len , if `SortCompare(j,k) < 0` (see `SortCompare` below), then $\pi(j) < \pi(k)$.

Here the notation `old[j]` is used to refer to the hypothetical result of calling the `[[Get]]` internal method of `obj` with argument j before this function is executed, and the notation `new[j]` to refer to the hypothetical result of calling the `[[Get]]` internal method of `obj` with argument j after this function has been executed.

A function `comparefn` is a consistent comparison function for a set of values S if all of the requirements below are met for all values a , b , and c (possibly the same value) in the set S : The notation $a <_{CF} b$ means `comparefn(a,b) < 0`; $a =_{CF} b$ means `comparefn(a,b) = 0` (of either sign); and $a >_{CF} b$ means `comparefn(a,b) > 0`.

- Calling `comparefn(a,b)` always returns the same value v when given a specific pair of values a and b as its two arguments. Furthermore, v has type `Number`, and v is not `NaN`. Note that this implies that exactly one of $a <_{CF} b$, $a =_{CF} b$, and $a >_{CF} b$ will be true for a given pair of a and b .
- Calling `comparefn(a,b)` does not modify the **this** object.
- $a =_{CF} a$ (reflexivity)
- If $a =_{CF} b$, then $b =_{CF} a$ (symmetry)
- If $a =_{CF} b$ and $b =_{CF} c$, then $a =_{CF} c$ (transitivity of $=_{CF}$)
- If $a <_{CF} b$ and $b <_{CF} c$, then $a <_{CF} c$ (transitivity of $<_{CF}$)
- If $a >_{CF} b$ and $b >_{CF} c$, then $a >_{CF} c$ (transitivity of $>_{CF}$)

NOTE

The above conditions are necessary and sufficient to ensure that `comparefn` divides the set S into equivalence classes and that these equivalence classes are totally ordered.

When the `SortCompare` abstract operation is called with two arguments j and k , the following steps are taken:

1. Let `jString` be `ToString(j)`.
2. Let `kString` be `ToString(k)`.
3. Let `hasj` be the result of calling the `[[HasProperty]]` internal method of `obj` with argument `jString`.
4. Let `hask` be the result of calling the `[[HasProperty]]` internal method of `obj` with argument `kString`.
5. If `hasj` and `hask` are both **false**, then return **+0**.
6. If `hasj` is **false**, then return 1.
7. If `hask` is **false**, then return -1.
8. Let x be the result of calling the `[[Get]]` internal method of `obj` with argument `jString`.
9. Let y be the result of calling the `[[Get]]` internal method of `obj` with argument `kString`.
10. If x and y are both **undefined**, return **+0**.
11. If x is **undefined**, return 1.
12. If y is **undefined**, return -1.
13. If the argument `comparefn` is not **undefined**, then
 - a. If `IsCallable(comparefn)` is **false**, throw a `TypeError` exception.
 - b. Return the result of calling the `[[Call]]` internal method of `comparefn` passing **undefined** as the **this** value and with arguments x and y .
14. Let `xString` be `ToString(x)`.
15. Let `yString` be `ToString(y)`.
16. If `xString < yString`, return -1.
17. If `xString > yString`, return 1.
18. Return **+0**.

NOTE

Because non-existent property values always compare greater than **undefined** property values, and **undefined** always compares greater than any other value, undefined property values always sort to the end of the result, followed by non-existent property values.

The **sort** function is intentionally generic; it does not require that its **this** value be an Array object. Therefore, it can be transferred to other kinds of objects for use as a method. Whether the **sort** function can be applied successfully to a host object is implementation-dependent.

15.4.4.12 Array.prototype.splice (start, deleteCount [, item1 [, item2 [, ...]]])

When the **splice** method is called with two or more arguments *start*, *deleteCount* and (optionally) *item1*, *item2*, etc., the *deleteCount* elements of the array starting at array index *start* are replaced by the arguments *item1*, *item2*, etc. An Array object containing the deleted elements (if any) is returned. The following steps are taken:

1. Let *O* be the result of calling ToObject passing the **this** value as the argument.
2. Let *A* be a new array created as if by the expression **new Array ()** where **Array** is the standard built-in constructor with that name.
3. Let *lenVal* be the result of calling the **[[Get]]** internal method of *O* with argument **"length"**.
4. Let *len* be ToUint32(*lenVal*).
5. Let *relativeStart* be ToInteger(*start*).
6. If *relativeStart* is negative, let *actualStart* be max((*len* + *relativeStart*),0); else let *actualStart* be min(*relativeStart*, *len*).
7. Let *actualDeleteCount* be min(max(ToInteger(*deleteCount*),0), *len* – *actualStart*).
8. Let *k* be 0.
9. Repeat, while *k* < *actualDeleteCount*
 - a. Let *from* be ToString(*relativeStart*+*k*).
 - b. Let *fromPresent* be the result of calling the **[[HasProperty]]** internal method of *O* with argument *from*.
 - c. If *fromPresent* is **true**, then
 - i. Let *fromValue* be the result of calling the **[[Get]]** internal method of *O* with argument *from*.
 - ii. Call the **[[DefineOwnProperty]]** internal method of *A* with arguments ToString(*k*), Property Descriptor **{[[Value]]: fromValue, [[Writable]]: true, [[Enumerable]]: true, [[Configurable]]: true}**, and **false**.
 - d. Increment *k* by 1.
10. Let *items* be an internal List whose elements are, in left to right order, the portion of the actual argument list starting with *item1*. The list will be empty if no such items are present.
11. Let *itemCount* be the number of elements in *items*.
12. If *itemCount* < *actualDeleteCount*, then
 - a. Let *k* be *actualStart*.
 - b. Repeat, while *k* < (*len* – *actualDeleteCount*)
 - i. Let *from* be ToString(*k*+*actualDeleteCount*).
 - ii. Let *to* be ToString(*k*+*itemCount*).
 - iii. Let *fromPresent* be the result of calling the **[[HasProperty]]** internal method of *O* with argument *from*.
 - iv. If *fromPresent* is **true**, then
 1. Let *fromValue* be the result of calling the **[[Get]]** internal method of *O* with argument *from*.
 2. Call the **[[Put]]** internal method of *O* with arguments *to*, *fromValue*, and **true**.
 - v. Else, *fromPresent* is **false**
 1. Call the **[[Delete]]** internal method of *O* with arguments *to* and **true**.
 - vi. Increase *k* by 1.
 - c. Let *k* be *len*.
 - d. Repeat, while *k* > (*len* – *actualDeleteCount* + *itemCount*)
 - i. Call the **[[Delete]]** internal method of *O* with arguments ToString(*k*-1) and **true**.
 - ii. Decrease *k* by 1.
13. Else if *itemCount* > *actualDeleteCount*, then

- a. Let k be $(len - actualDeleteCount)$.
- b. Repeat, while $k > actualStart$
 - i. Let $from$ be $ToString(k + actualDeleteCount - 1)$.
 - ii. Let to be $ToString(k + itemCount - 1)$
 - iii. Let $fromPresent$ be the result of calling the `[[HasProperty]]` internal method of O with argument $from$.
 - iv. If $fromPresent$ is **true**, then
 1. Let $fromValue$ be the result of calling the `[[Get]]` internal method of O with argument $from$.
 2. Call the `[[Put]]` internal method of O with arguments to , $fromValue$, and **true**.
 - v. Else, $fromPresent$ is **false**
 1. Call the `[[Delete]]` internal method of O with argument to and **true**.
 - vi. Decrease k by 1.
14. Let k be $actualStart$.
15. Repeat, while $items$ is not empty
 - a. Remove the first element from $items$ and let E be the value of that element.
 - b. Call the `[[Put]]` internal method of O with arguments $ToString(k)$, E , and **true**.
 - c. Increase k by 1.
16. Call the `[[Put]]` internal method of O with arguments **"length"**, $(len - actualDeleteCount + itemCount)$, and **true**.
17. Return A .

The **length** property of the **splice** method is **2**.

NOTE

The **splice** function is intentionally generic; it does not require that its **this** value be an Array object. Therefore it can be transferred to other kinds of objects for use as a method. Whether the **splice** function can be applied successfully to a host object is implementation-dependent.

15.4.4.13 Array.prototype.unshift ([item1 [, item2 [, ...]]])

The arguments are prepended to the start of the array, such that their order within the array is the same as the order in which they appear in the argument list.

When the **unshift** method is called with zero or more arguments $item1$, $item2$, etc., the following steps are taken:

1. Let O be the result of calling `ToObject` passing the **this** value as the argument.
2. Let $lenVal$ be the result of calling the `[[Get]]` internal method of O with argument **"length"**.
3. Let len be `ToUint32(lenVal)`.
4. Let $argCount$ be the number of actual arguments.
5. Let k be len .
6. Repeat, while $k > 0$,
 - a. Let $from$ be $ToString(k-1)$.
 - b. Let to be $ToString(k+argCount-1)$.
 - c. Let $fromPresent$ be the result of calling the `[[HasProperty]]` internal method of O with argument $from$.
 - d. If $fromPresent$ is **true**, then
 - i. Let $fromValue$ be the result of calling the `[[Get]]` internal method of O with argument $from$.
 - ii. Call the `[[Put]]` internal method of O with arguments to , $fromValue$, and **true**.
 - e. Else, $fromPresent$ is **false**
 - i. Call the `[[Delete]]` internal method of O with arguments to , and **true**.
 - f. Decrease k by 1.
7. Let j be 0.
8. Let $items$ be an internal List whose elements are, in left to right order, the arguments that were passed to this function invocation.
9. Repeat, while $items$ is not empty
 - a. Remove the first element from $items$ and let E be the value of that element.
 - b. Call the `[[Put]]` internal method of O with arguments $ToString(j)$, E , and **true**.
 - c. Increase j by 1.

10. Call the `[[Put]]` internal method of *O* with arguments **"length"**, *len+argCount*, and **true**.
11. Return *len+argCount*.

The **length** property of the **unshift** method is **1**.

NOTE

The **unshift** function is intentionally generic; it does not require that its **this** value be an Array object. Therefore it can be transferred to other kinds of objects for use as a method. Whether the **unshift** function can be applied successfully to a host object is implementation-dependent.

15.4.4.14 **Array.prototype.indexOf (searchElement [, fromIndex])**

indexOf compares *searchElement* to the elements of the array, in ascending order, using the internal SameValue comparison operation (9.12), and if found at one or more positions, returns the index of the first such position; otherwise, -1 is returned.

The optional second argument *fromIndex* defaults to 0 (i.e. the whole array is searched). If it is greater than or equal to the length of the array, -1 is returned, i.e. the array will not be searched. If it is negative, it is used as the offset from the end of the array to compute *fromIndex*. If the computed index is less than 0, the whole array will be searched.

When the **indexOf** method is called with one or two arguments, the following steps are taken:

1. Let *O* be the result of calling `ToObject` passing the **this** value as the argument.
2. Let *lenValue* be the result of calling the `[[Get]]` internal method of *O* with the argument **"length"**.
3. Let *len* be `ToUint32(lenValue)`.
4. If *len* is 0, return -1.
5. If argument *fromIndex* was passed let *n* be `ToInteger(fromIndex)`; else let *n* be 0.
6. If $n \geq len$, return -1.
7. If $n \geq 0$, then
 - a. Let *k* be *n*.
8. Else, $n < 0$
 - a. Let *k* be *len* - `abs(n)`.
 - b. If *k* is less than 0, then let *k* be 0.
9. Repeat, while $k < len$
 - a. Let *kPresent* be the result of calling the `[[HasProperty]]` internal method of *O* with argument `ToString(k)`.
 - b. If *kPresent* is not **undefined**, then
 - i. Let *elementK* be the result of calling the `[[Get]]` internal method of *O* with the argument `ToString(k)`.
 - ii. If `SameValue(searchElement,elementK)` is **true**, return *k*.
 - c. Increase *k* by 1.
10. Return -1.

NOTE

The **indexOf** function is intentionally generic; it does not require that its **this** value be an Array object. Therefore it can be transferred to other kinds of objects for use as a method. Whether the **indexOf** function can be applied successfully to a host object is implementation-dependent.

15.4.4.15 **Array.prototype.lastIndexOf (searchElement [, fromIndex])**

lastIndexOf compares *searchElement* to the elements of the array in descending order using the internal SameValue comparison operation (9.12), and if found at one or more positions, returns the index of the last such position; otherwise, -1 is returned.

The optional second argument *fromIndex* defaults to the array's length (i.e. the whole array is searched). If it is greater than or equal to the length of the array, the whole array will be searched. If it is negative, it is used as the offset from the end of the array to compute *fromIndex*. If the computed index is less than 0, -1 is returned.

When the **lastIndexOf** method is called with one or two arguments, the following steps are taken:

1. Let *O* be the result of calling `ToObject` passing the **this** value as the argument.
2. Let *lenValue* be the result of calling the `[[Get]]` internal method of *O* with the argument **"length"**.
3. Let *len* be `ToUint32(lenValue)`.
4. If *len* is 0, return -1.
5. If argument *fromIndex* was passed let *n* be `ToInteger(fromIndex)`; else let *n* be *len*.
6. If $n \geq 0$, then let *k* be $\min(n, len - 1)$.
7. Else, $n < 0$
 - a. Let *k* be $len - \text{abs}(n)$.
8. Repeat, while $k \geq 0$
 - a. Let *kPresent* be the result of calling the `[[HasProperty]]` internal method of *O* with argument `Tostring(k)`.
 - b. If *kPresent* is not **undefined**, then
 - i. Let *elementK* be the result of calling the `[[Get]]` internal method of *O* with the argument `Tostring(k)`.
 - ii. If `SameValue(searchElement, elementK)` is **true**, return *k*.
 - c. Decrease *k* by 1.
9. Return -1.

NOTE

The **lastIndexOf** function is intentionally generic; it does not require that its **this** value be an Array object. Therefore it can be transferred to other kinds of objects for use as a method. Whether the **lastIndexOf** function can be applied successfully to a host object is implementation-dependent.

15.4.4.16 **Array.prototype.every** (*callbackfn* [, *thisArg*])

callbackfn should be a function that accepts three arguments and returns a value that is coercible to the boolean value **true** or **false**. **every** calls *callbackfn* once for each element present in the array, in ascending order, until it finds one where *callbackfn* returns **false**. If such an element is found, **every** immediately returns **false**. Otherwise, if *callbackfn* returned **true** for all elements, **every** will return **true**. *callbackfn* is called only for elements of the array which actually exist; it is not called for missing elements of the array.

If a *thisArg* parameter is provided, it will be used as the **this** value for each invocation of *callbackfn*. If it is not provided, **undefined** is used instead.

callbackfn is called with three arguments: the value of the element, the index of the element, and the object being traversed.

every does not directly mutate the object on which it is called but the object may be mutated by the calls to *callbackfn*.

The range of elements processed by **every** is set before the first call to *callbackfn*. Elements which are appended to the array after the call to **every** begins will not be visited by *callbackfn*. If existing elements of the array are changed, their value as passed to *callbackfn* will be the value at the time **every** visits them; elements that are deleted after the call to **every** begins and before being visited are not visited. **every** acts like the "for all" quantifier in mathematics. In particular, for an empty array, it returns **true**.

When the **every** method is called with one or two arguments, the following steps are taken:

1. Let *O* be the result of calling `ToObject` passing the **this** value as the argument.
2. Let *lenValue* be the result of calling the `[[Get]]` internal method of *O* with the argument **"length"**.
3. Let *len* be `ToUint32(lenValue)`.
4. If `IsCallable(callbackfn)` is **false**, throw a **TypeError** exception.
5. If *thisArg* was supplied, let *T* be *thisArg*; else let *T* be **undefined**.
6. Let *k* be 0.
7. Repeat, while $k < len$
 - a. Let *Pk* be `Tostring(k)`.

- b. Let *kPresent* be the result of calling the `[[HasProperty]]` internal method of *O* with argument *Pk*.
 - c. If *kPresent* is **true**, then
 - i. Let *kValue* be the result of calling the `[[Get]]` internal method of *O* with argument *Pk*.
 - ii. Let *testResult* be the result of calling the `[[Call]]` internal method of *callbackfn* with *T* as the **this** value and argument list containing *kValue*, *k*, and *O*.
 - iii. If `ToBoolean(testResult)` is **false**, return **false**.
 - d. Increase *k* by 1.
8. Return **true**.

NOTE

The **every** function is intentionally generic; it does not require that its **this** value be an Array object. Therefore it can be transferred to other kinds of objects for use as a method. Whether the **every** function can be applied successfully to a host object is implementation-dependent.

15.4.4.17 Array.prototype.some (callbackfn [, thisArg])

callbackfn should be a function that accepts three arguments and returns a value that is coercible to the boolean value **true** or **false**. **some** calls *callbackfn* once for each element present in the array, in ascending order, until it finds one where *callbackfn* returns **true**. If such an element is found, **some** immediately returns **true**. Otherwise, **some** returns **false**. *callbackfn* is called only for elements of the array which actually exist; it is not called for missing elements of the array.

If a *thisArg* parameter is provided, it will be used as the **this** value for each invocation of *callbackfn*. If it is not provided, **undefined** is used instead.

callbackfn is called with three arguments: the value of the element, the index of the element, and the object being traversed.

some does not directly mutate the object on which it is called but the object may be mutated by the calls to *callbackfn*.

The range of elements processed by **some** is set before the first call to *callbackfn*. Elements that are appended to the array after the call to **some** begins will not be visited by *callbackfn*. If existing elements of the array are changed, their value as passed to *callbackfn* will be the value at the time that **some** visits them; elements that are deleted after the call to **some** begins and before being visited are not visited. **some** acts like the "exists" quantifier in mathematics. In particular, for an empty array, it returns **false**.

When the **some** method is called with one or two arguments, the following steps are taken:

1. Let *O* be the result of calling `ToObject` passing the **this** value as the argument.
2. Let *lenValue* be the result of calling the `[[Get]]` internal method of *O* with the argument **"length"**.
3. Let *len* be `ToUint32(lenValue)`.
4. If `IsCallable(callbackfn)` is **false**, throw a **TypeError** exception.
5. If *thisArg* was supplied, let *T* be *thisArg*; else let *T* be **undefined**.
6. Let *k* be 0.
7. Repeat, while *k* < *len*
 - a. Let *Pk* be `ToString(k)`.
 - b. Let *kPresent* be the result of calling the `[[HasProperty]]` internal method of *O* with argument *Pk*.
 - c. If *kPresent* is **true**, then
 - i. Let *kValue* be the result of calling the `[[Get]]` internal method of *O* with argument *Pk*.
 - ii. Let *testResult* be the result of calling the `[[Call]]` internal method of *callbackfn* with *T* as the **this** value and argument list containing *kValue*, *k*, and *O*.
 - iii. If `ToBoolean(testResult)` is **true**, return **true**.
 - d. Increase *k* by 1.
8. Return **false**.

NOTE

The **some** function is intentionally generic; it does not require that its **this** value be an Array object. Therefore it can be transferred to other kinds of objects for use as a method. Whether the **some** function can be applied successfully to a host object is implementation-dependent.

15.4.4.18 Array.prototype.forEach (callbackfn [, thisArg])

callbackfn should be a function that accepts three arguments. **forEach** calls *callbackfn* once for each element present in the array, in ascending order. *callbackfn* is called only for elements of the array which actually exist; it is not called for missing elements of the array.

If a *thisArg* parameter is provided, it will be used as the **this** value for each invocation of *callbackfn*. If it is not provided, **undefined** is used instead.

callbackfn is called with three arguments: the value of the element, the index of the element, and the object being traversed.

forEach does not directly mutate the object on which it is called but the object may be mutated by the calls to *callbackfn*.

The range of elements processed by **forEach** is set before the first call to *callbackfn*. Elements which are appended to the array after the call to **forEach** begins will not be visited by *callbackfn*. If existing elements of the array are changed, their value as passed to callback will be the value at the time **forEach** visits them; elements that are deleted after the call to **forEach** begins and before being visited are not visited.

When the **forEach** method is called with one or two arguments, the following steps are taken:

1. Let *O* be the result of calling **ToObject** passing the **this** value as the argument.
2. Let *lenValue* be the result of calling the **[[Get]]** internal method of *O* with the argument **"length"**.
3. Let *len* be **ToUint32(lenValue)**.
4. If **IsCallable(callbackfn)** is **false**, throw a **TypeError** exception.
5. If *thisArg* was supplied, let *T* be *thisArg*; else let *T* be **undefined**.
6. Let *k* be 0.
7. Repeat, while *k* < *len*
 - a. Let *Pk* be **Tostring(k)**.
 - b. Let *kPresent* be the result of calling the **[[HasProperty]]** internal method of *O* with argument *Pk*.
 - c. If *kPresent* is **true**, then
 - i. Let *kValue* be the result of calling the **[[Get]]** internal method of *O* with argument *Pk*.
 - ii. Call the **[[Call]]** internal method of *callbackfn* with *T* as the **this** value and argument list containing *kValue*, *k*, and *O*.
 - d. Increase *k* by 1.
8. Return.

NOTE

The **forEach** function is intentionally generic; it does not require that its **this** value be an Array object. Therefore it can be transferred to other kinds of objects for use as a method. Whether the **forEach** function can be applied successfully to a host object is implementation-dependent.

15.4.4.19 Array.prototype.map (callbackfn [, thisArg])

callbackfn should be a function that accepts three arguments. **map** calls *callbackfn* once for each element in the array, in ascending order, and constructs a new Array from the results. *callbackfn* is called only for elements of the array which actually exist; it is not called for missing elements of the array.

If a *thisArg* parameter is provided, it will be used as the **this** value for each invocation of *callbackfn*. If it is not provided, **undefined** is used instead.

callbackfn is called with three arguments: the value of the element, the index of the element, and the object being traversed.

map does not directly mutate the object on which it is called but the object may be mutated by the calls to *callbackfn*.

The range of elements processed by **map** is set before the first call to *callbackfn*. Elements which are appended to the array after the call to **map** begins will not be visited by *callbackfn*. If existing elements of the array are changed, their value as passed to *callbackfn* will be the value at the time **map** visits them; elements that are deleted after the call to **map** begins and before being visited are not visited.

When the **map** method is called with one or two arguments, the following steps are taken:

1. Let *O* be the result of calling `ToObject` passing the **this** value as the argument.
2. Let *lenValue* be the result of calling the `[[Get]]` internal method of *O* with the argument **"length"**.
3. Let *len* be `ToUint32(lenValue)`.
4. If `IsCallable(callbackfn)` is **false**, throw a **TypeError** exception.
5. If *thisArg* was supplied, let *T* be *thisArg*; else let *T* be **undefined**.
6. Let *A* be a new array created as if by the expression `new Array(len)` where **Array** is the standard built-in constructor with that name and *len* is the value of *len*.
7. Let *k* be 0.
8. Repeat, while *k* < *len*
 - a. Let *Pk* be `ToString(k)`.
 - b. Let *kPresent* be the result of calling the `[[HasProperty]]` internal method of *O* with argument *Pk*.
 - c. If *kPresent* is **true**, then
 - i. Let *kValue* be the result of calling the `[[Get]]` internal method of *O* with argument *Pk*.
 - ii. Let *mappedValue* be the result of calling the `[[Call]]` internal method of *callbackfn* with *T* as the **this** value and argument list containing *kValue*, *k*, and *O*.
 - iii. Call the `[[DefineOwnProperty]]` internal method of *A* with arguments *Pk*, Property Descriptor `{[[Value]]: mappedValue, [[Writable]]: true, [[Enumerable]]: true, [[Configurable]]: true}`, and **false**.
 - d. Increase *k* by 1.
9. Return *A*.

NOTE

*The **map** function is intentionally generic; it does not require that its **this** value be an Array object. Therefore it can be transferred to other kinds of objects for use as a method. Whether the **map** function can be applied successfully to a host object is implementation-dependent.*

15.4.4.20 **Array.prototype.filter** (*callbackfn* [, *thisArg*])

callbackfn should be a function that accepts three arguments and returns a value that is coercible to the boolean value **true** or **false**. **filter** calls *callbackfn* once for each element in the array, in ascending order, and constructs a new array of all the values for which *callbackfn* returns **true**. *callbackfn* is called only for elements of the array which actually exist; it is not called for missing elements of the array.

If a *thisArg* parameter is provided, it will be used as the **this** value for each invocation of *callbackfn*. If it is not provided, **undefined** is used instead.

callbackfn is called with three arguments: the value of the element, the index of the element, and the object being traversed.

filter does not directly mutate the object on which it is called but the object may be mutated by the calls to *callbackfn*.

The range of elements processed by **filter** is set before the first call to *callbackfn*. Elements which are appended to the array after the call to **filter** begins will not be visited by *callbackfn*. If existing elements of the array are changed their value as passed to *callbackfn* will be the value at the time **filter** visits them; elements that are deleted after the call to **filter** begins and before being visited are not visited.

When the **filter** method is called with one or two arguments, the following steps are taken:

1. Let *O* be the result of calling `ToObject` passing the **this** value as the argument.
2. Let *lenValue* be the result of calling the `[[Get]]` internal method of *O* with the argument **"length"**.
3. Let *len* be `ToUint32(lenValue)`.
4. If `IsCallable(callbackfn)` is **false**, throw a **TypeError** exception.
5. If *thisArg* was supplied, let *T* be *thisArg*; else let *T* be **undefined**.
6. Let *A* be a new array created as if by the expression `new Array()` where **Array** is the standard built-in constructor with that name.
7. Let *k* be 0.
8. Let *to* be 0.
9. Repeat, while *k* < *len*
 - a. Let *Pk* be `Tostring(k)`.
 - b. Let *kPresent* be the result of calling the `[[HasProperty]]` internal method of *O* with argument *Pk*.
 - c. If *kPresent* is **true**, then
 - i. Let *kValue* be the result of calling the `[[Get]]` internal method of *O* with argument *Pk*.
 - ii. Let *selected* be the result of calling the `[[Call]]` internal method of *callbackfn* with *T* as the **this** value and argument list containing *kValue*, *k*, and *O*.
 - iii. If `ToBoolean(selected)` is **true**, then
 1. Call the `[[DefineOwnProperty]]` internal method of *A* with arguments `Tostring(to)`, Property Descriptor `{[[Value]]: kValue, [[Writable]]: true, [[Enumerable]]: true, [[Configurable]]: true}`, and **false**.
 2. Increase *to* by 1.
 - d. Increase *k* by 1.
10. Return *A*.

NOTE

The **filter** function is intentionally generic; it does not require that its **this** value be an Array object. Therefore it can be transferred to other kinds of objects for use as a method. Whether the **filter** function can be applied successfully to a host object is implementation-dependent.

15.4.4.21 **Array.prototype.reduce (callbackfn [, initialValue])**

callbackfn should be a function that takes four arguments. **reduce** calls the callback, as a function, once for each element present in the array, in ascending order.

callbackfn is called with four arguments: the *previousValue* (or value from the previous call to *callbackfn*), the *currentValue* (value of the current element), the *currentIndex*, and the object being traversed. The first time that callback is called, the *previousValue* and *currentValue* can be one of two values. If an *initialValue* was provided in the call to **reduce**, then *previousValue* will be equal to *initialValue* and *currentValue* will be equal to the first value in the array. If no *initialValue* was provided, then *previousValue* will be equal to the first value in the array and *currentValue* will be equal to the second. It is a **TypeError** if the array contains no elements and *initialValue* is not provided.

reduce does not directly mutate the object on which it is called but the object may be mutated by the calls to *callbackfn*.

The range of elements processed by **reduce** is set before the first call to *callbackfn*. Elements that are appended to the array after the call to **reduce** begins will not be visited by *callbackfn*. If existing elements of the array are changed, their value as passed to *callbackfn* will be the value at the time **reduce** visits them; elements that are deleted after the call to **filter** begins and before being visited are not visited.

When the **reduce** method is called with one or two arguments, the following steps are taken:

1. Let *O* be the result of calling `ToObject` passing the **this** value as the argument.
2. Let *lenValue* be the result of calling the `[[Get]]` internal method of *O* with the argument **"length"**.

3. Let *len* be `ToUint32(lenValue)`.
4. If `IsCallable(callbackfn)` is **false**, throw a **TypeError** exception.
5. If *len* is 0 and *initialValue* is not present, throw a **TypeError** exception.
6. Let *k* be 0.
7. If *initialValue* is present, then
 - a. Set *accumulator* to *initialValue*.
8. Else, *initialValue* is not present
 - a. Let *kPresent* be **false**.
 - b. Repeat, while *kPresent* is **false** and $k < len$
 - i. Let *Pk* be `Tostring(k)`.
 - ii. Let *kPresent* be the result of calling the `[[HasProperty]]` internal method of *O* with argument *Pk*.
 - iii. If *kPresent* is **true**, then
 1. Let *accumulator* be the result of calling the `[[Get]]` internal method of *O* with argument *Pk*.
 - iv. Increase *k* by 1.
 - c. If *kPresent* is **false**, throw a **TypeError** exception.
9. Repeat, while $k < len$
 - a. Let *Pk* be `Tostring(k)`.
 - b. Let *kPresent* be the result of calling the `[[HasProperty]]` internal method of *O* with argument *Pk*.
 - c. If *kPresent* is **true**, then
 - i. Let *kValue* be the result of calling the `[[Get]]` internal method of *O* with argument *Pk*.
 - ii. Let *accumulator* be the result of calling the `[[Call]]` internal method of *callbackfn* with **null** as the **this** value and argument list containing *accumulator*, *kValue*, *k*, and *O*.
 - d. Increase *k* by 1.
10. Return *accumulator*.

NOTE

The **reduce** function is intentionally generic; it does not require that its **this** value be an Array object. Therefore it can be transferred to other kinds of objects for use as a method. Whether the **reduce** function can be applied successfully to a host object is implementation-dependent.

15.4.4.22 **Array.prototype.reduceRight (callbackfn [, initialValue])**

callbackfn should be a function that takes four arguments. **reduceRight** calls the callback, as a function, once for each element present in the array, in descending order.

callbackfn is called with four arguments: the previousValue (or value from the previous call to *callbackfn*), the currentValue (value of the current element), the currentIndex, and the object being traversed. The first time the function is called, the previousValue and currentValue can be one of two values. If an *initialValue* was provided in the call to **reduceRight**, then previousValue will be equal to *initialValue* and currentValue will be equal to the last value in the array. If no *initialValue* was provided, then previousValue will be equal to the last value in the array and currentValue will be equal to the second-to-last value. It is a **TypeError** if the array contains no elements and *initialValue* is not provided.

reduceRight does not directly mutate the object on which it is called but the object may be mutated by the calls to *callbackfn*.

The range of elements processed by **reduceRight** is set before the first call to *callbackfn*. Elements that are appended to the array after the call to **reduceRight** begins will not be visited by *callbackfn*. If existing elements of the array are changed by *callbackfn*, their value as passed to *callbackfn* will be the value at the time **reduceRight** visits them; elements that are deleted after the call to **filter** begins and before being visited are not visited.

When the **reduceRight** method is called with one or two arguments, the following steps are taken:

1. Let *O* be the result of calling `ToObject` passing the **this** value as the argument.
2. Let *lenValue* be the result of calling the `[[Get]]` internal method of *O* with the argument **"length"**.

3. Let *len* be `ToUint32(lenValue)`.
 4. If `IsCallable(callbackfn)` is **false**, throw a **TypeError** exception.
 5. If *len* is 0 and *initialValue* is not present, throw a **TypeError** exception.
 6. Let *k* be *len*-1.
 7. If *initialValue* is present, then
 - a. Set *accumulator* to *initialValue*.
 8. Else, *initialValue* is not present
 - a. Let *kPresent* be **false**.
 - b. Repeat, while *kPresent* is **false** and $k \geq 0$
 - i. Let *Pk* be `Tostring(k)`.
 - ii. Let *kPresent* be the result of calling the `[[HasProperty]]` internal method of *O* with argument *Pk*.
 - iii. If *kPresent* is **true**, then
 1. Let *accumulator* be the result of calling the `[[Get]]` internal method of *O* with argument *Pk*.
 - iv. Decrease *k* by 1.
 - c. If *kPresent* is **false**, throw a **TypeError** exception.
9. Repeat, while $k \geq 0$
 - a. Let *Pk* be `Tostring(k)`.
 - b. Let *kPresent* be the result of calling the `[[HasProperty]]` internal method of *O* with argument *Pk*.
 - c. If *kPresent* is **true**, then
 - i. Let *kValue* be the result of calling the `[[Get]]` internal method of *O* with argument *Pk*.
 - ii. Let *accumulator* be the result of calling the `[[Call]]` internal method of *callbackfn* with **null** as the **this** value and argument list containing *accumulator*, *kValue*, *k*, and *O*.
 - d. Decrease *k* by 1.
10. Return *accumulator*.

NOTE

The **reduceRight** function is intentionally generic; it does not require that its this value be an Array object. Therefore it can be transferred to other kinds of objects for use as a method. Whether the **reduceRight** function can be applied successfully to a host object is implementation-dependent.

15.4.5 Properties of Array Instances

Array instances inherit properties from the Array prototype object and their `[[Class]]` internal property value is **"Array"**. Array instances also have the following properties.

15.4.5.1 `[[DefineOwnProperty]] (P, Desc, Throw)`

Array objects use a variation of the `[[DefineOwnProperty]]` internal method used for other native ECMAScript objects (8.12.9).

Assume *A* is an Array object, *Desc* is a Property Descriptor, and *Throw* is a boolean flag.

In the following algorithm, the term “Reject” means “If *Throw* is **true**, then throw a **TypeError** exception, otherwise return **false**.”

When the `[[DefineOwnProperty]]` internal method of *A* is called with property *P*, Property Descriptor *Desc*, and Boolean flag *Throw*, the following steps are taken:

1. Let *oldLenDesc* be the result of calling the `[[GetOwnProperty]]` internal method of *A* passing **"length"** as the argument. The result will never be **undefined** or an accessor descriptor because Array objects are created with a length data property that cannot be deleted or reconfigured.
2. Let *oldLen* be *oldLenDesc*.`[[Value]]`.
3. If *P* is **"length"**, then
 - a. If the `[[Value]]` field of *Desc* is present, then
 - i. Let *newLenDesc* be a copy of *Desc*.
 - ii. Let *newLen* be `ToUint32(Desc. [[Value]])`.
 - iii. If *newLen* is not equal to `ToNumber(Desc. [[Value]])`, throw a **RangeError** exception.

- iv. Set *newLenDesc*.[[Value]] to *newLen*.
 - v. Let *succeeded* be the result of calling the default [[DefineOwnProperty]] internal method (8.12.9) on *A* passing "**length**", *newLenDesc*, and **false** as arguments.
 - vi. Reject if *succeeded* is **false**.
 - vii. While *newLen* < *oldLen* repeat,
 - 1. Set *oldLen* to *oldLen* - 1.
 - 2. Let *cantDelete* be the result of calling the [[Delete]] internal method of *A* passing *ToString(oldLen)* and **false** as arguments.
 - 3. If *cantDelete* is **true**, then
 - a. Set *newLenDesc*.[[Value]] to *oldLen*+1.
 - b. Call the default [[DefineOwnProperty]] internal method (8.12.9) on *A* passing "**length**", *newLenDesc*, and **false** as arguments.
 - c. Return **true**.
 - viii. Return **true**.
 - b. Let *succeeded* be the result of calling the default [[DefineOwnProperty]] internal method (8.12.9) on *A* passing "**length**", *Desc*, and *Throw* as arguments.
 - c. Return *succeeded*.
4. Else if *P* is an array index (15.4), then
- a. Let *index* be *ToUint32(P)*.
 - b. Reject if *index* ≥ *oldLen* and *oldLenDesc*.[[Writable]] is **false**.
 - c. Let *succeeded* be the result of calling the default [[DefineOwnProperty]] internal method (8.12.9) on *A* passing *P*, *Desc*, and **false** as arguments.
 - d. Reject if *succeeded* is **false**.
 - e. If *index* ≥ *oldLen*
 - i. Set *oldLenDesc*.[[Value]] to *index* + 1.
 - ii. Calling the default [[DefineOwnProperty]] internal method (8.12.9) on *A* passing "**length**", *oldLenDesc*, and **false** as arguments. This call will always return **true**.
 - f. Return **true**.
5. Return the result of calling the default [[DefineOwnProperty]] internal method (8.12.9) on *A* passing *P*, *Desc*, and *Throw* as arguments.

15.4.5.2 length

The **length** property of this Array object is a data property whose value is always numerically greater than the name of every deletable property whose name is an array index.

The **length** property initially has the attributes { [[Writable]]: **true**, [[Enumerable]]: **false**, [[Configurable]]: **false** }.

NOTE

Attempting to set the length property of an Array object to a value that is numerically less than or equal to the largest numeric property name of an existing array indexed non-deletable property of the array will result in the length being set to a numeric value that is one greater than that largest numeric property name. See 15.4.5.1.

15.5 String Objects

15.5.1 The String Constructor Called as a Function

When **String** is called as a function rather than as a constructor, it performs a type conversion.

15.5.1.1 String ([value])

Returns a string value (not a String object) computed by *ToString(value)*. If *value* is not supplied, the empty string "" is returned.

15.5.2 The String Constructor

When **String** is called as part of a **new** expression, it is a constructor: it initialises the newly created object.

15.5.2.1 new String ([value])

The [[Prototype]] internal property of the newly constructed object is set to the original String prototype object, the one that is the initial value of **String.prototype** (15.5.3.1).

The `[[Class]]` internal property of the newly constructed object is set to `"String"`.

The `[[Extensible]]` internal property of the newly constructed object is set to `true`.

The `[[PrimitiveValue]]` internal property of the newly constructed object is set to `ToString(value)`, or to the empty string if `value` is not supplied.

15.5.3 Properties of the String Constructor

The value of the `[[Prototype]]` internal property of the String constructor is the Function prototype object (15.3.4).

Besides the internal properties and the `length` property (whose value is `1`), the String constructor has the following properties:

15.5.3.1 String.prototype

The initial value of `String.prototype` is the String prototype object (15.5.4).

This property has the attributes { `[[Writable]]`: `false`, `[[Enumerable]]`: `false`, `[[Configurable]]`: `false` }.

15.5.3.2 String.fromCharCode ([char0 [, char1 [, ...]]])

Returns a string value containing as many characters as the number of arguments. Each argument specifies one character of the resulting string, with the first argument specifying the first character, and so on, from left to right. An argument is converted to a character by applying the operation `ToUint16` (9.7) and regarding the resulting 16-bit integer as the code unit value of a character. If no arguments are supplied, the result is the empty string.

The `length` property of the `fromCharCode` function is `1`.

15.5.4 Properties of the String Prototype Object

The String prototype object is itself a String object (its `[[Class]]` is `"String"`) whose value is an empty string.

The value of the `[[Prototype]]` internal property of the String prototype object is the standard built-in Object prototype object (15.2.4).

15.5.4.1 String.prototype.constructor

The initial value of `String.prototype.constructor` is the built-in `String` constructor.

15.5.4.2 String.prototype.toString ()

Returns this string value. (Note that, for a String object, the `toString` method happens to return the same thing as the `valueOf` method.)

The `toString` function is not generic; it throws a `TypeError` exception if its `this` value is not a String or a String object. Therefore, it cannot be transferred to other kinds of objects for use as a method.

15.5.4.3 String.prototype.valueOf ()

Returns this string value.

The `valueOf` function is not generic; it throws a `TypeError` exception if its `this` value is not a String or String object. Therefore, it cannot be transferred to other kinds of objects for use as a method.

15.5.4.4 String.prototype.charAt (pos)

Returns a string containing the character at position `pos` in the string resulting from converting this object to a string. If there is no character at that position, the result is the empty string. The result is a string value, not a String object.

If `pos` is a value of Number type that is an integer, then the result of `x.charAt(pos)` is equal to the result of `x.substring(pos, pos+1)`.

When the `charAt` method is called with one argument `pos`, the following steps are taken:

1. Call `CheckObjectCoercible` passing the `this` value as its argument.
2. Let `S` be the result of calling `ToString`, giving it the `this` value as its argument.

3. Let *position* be `ToInteger(pos)`.
4. Let *size* be the number of characters in *S*.
5. If *position* < 0 or *position* ≥ *size*, return the empty string.
6. Return a string of length 1, containing one character from *S*, namely the character at position *position*, where the first (leftmost) character in *S* is considered to be at position 0, the next one at position 1, and so on.

NOTE

The **charAt** function is intentionally generic; it does not require that its **this** value be a *String* object. Therefore, it can be transferred to other kinds of objects for use as a method.

15.5.4.5 **String.prototype.charCodeAt (pos)**

Returns a number (a nonnegative integer less than 2¹⁶) representing the code unit value of the character at position *pos* in the string resulting from converting this object to a string. If there is no character at that position, the result is **NaN**.

When the **charCodeAt** method is called with one argument *pos*, the following steps are taken:

1. Call `CheckObjectCoercible` passing the **this** value as its argument.
2. Let *S* be the result of calling `ToString`, giving it the **this** value as its argument.
3. Let *position* be `ToInteger(pos)`.
4. Let *size* be the number of characters in *S*.
5. If *position* < 0 or *position* ≥ *size*, return **NaN**.
6. Return a value of `Number` type, whose value is the code unit value of the character at position *position* in the string *S*, where the first (leftmost) character in *S* is considered to be at position 0, the next one at position 1, and so on.

NOTE

The **charCodeAt** function is intentionally generic; it does not require that its **this** value be a *String* object. Therefore it can be transferred to other kinds of objects for use as a method.

15.5.4.6 **String.prototype.concat ([string1 [, string2 [, ...]]])**

When the **concat** method is called with zero or more arguments *string1*, *string2*, etc., it returns a string consisting of the characters of this object (converted to a string) followed by the characters of each of *string1*, *string2*, etc. (where each argument is converted to a string). The result is a string value, not a *String* object. The following steps are taken:

1. Call `CheckObjectCoercible` passing the **this** value as its argument.
2. Let *S* be the result of calling `ToString`, giving it the **this** value as its argument.
3. Let *args* be an internal list that is a copy of the argument list passed to this function.
4. Let *R* be *S*.
5. Repeat, while *args* is not empty
 - Remove the first element from *args* and let *next* be the value of that element.
 - Let *R* be the string value consisting of the characters in the previous value of *R* followed by the characters of `ToString(next)`.
6. Return *R*.

The **length** property of the **concat** method is **1**.

NOTE

The **concat** function is intentionally generic; it does not require that its **this** value be a *String* object. Therefore it can be transferred to other kinds of objects for use as a method.

15.5.4.7 **String.prototype.indexOf (searchString, position)**

If *searchString* appears as a substring of the result of converting this object to a string, at one or more positions that are greater than or equal to *position*, then the index of the smallest such position is returned; otherwise, **-1** is returned. If *position* is **undefined**, 0 is assumed, so as to search all of the string.

The **indexOf** method takes two arguments, *searchString* and *position*, and performs the following steps:

1. Call **CheckObjectCoercible** passing the **this** value as its argument.
2. Let *S* be the result of calling **ToString**, giving it the **this** value as its argument.
3. Let *searchStr* be **ToString**(*searchString*).
4. Let *pos* be **ToInteger**(*position*). (If *position* is **undefined**, this step produces the value **0**).
5. Let *len* be the number of characters in *S*.
6. Let *start* be **min**(**max**(*pos*, **0**), *len*).
7. Let *searchLen* be the number of characters in *searchStr*.
8. Return the smallest possible integer *k* not smaller than *start* such that *k*+ *searchLen* is not greater than *len*, and for all nonnegative integers *j* less than *searchLen*, the character at position *k*+*j* of *S* is the same as the character at position *j* of *searchStr*; but if there is no such integer *k*, then return the value **-1**.

The **length** property of the **indexOf** method is **1**.

NOTE

The **indexOf** function is intentionally generic; it does not require that its **this** value be a *String* object. Therefore, it can be transferred to other kinds of objects for use as a method.

15.5.4.8 **String.prototype.lastIndexOf** (*searchString*, *position*)

If *searchString* appears as a substring of the result of converting this object to a string at one or more positions that are smaller than or equal to *position*, then the index of the greatest such position is returned; otherwise, **-1** is returned. If *position* is **undefined**, the length of the string value is assumed, so as to search all of the string.

The **lastIndexOf** method takes two arguments, *searchString* and *position*, and performs the following steps:

1. Call **CheckObjectCoercible** passing the **this** value as its argument.
2. Let *S* be the result of calling **ToString**, giving it the **this** value as its argument.
3. Let *searchStr* be **ToString**(*searchString*).
4. Let *numPos* be **ToNumber**(*position*). (If *position* is **undefined**, this step produces the value **NaN**).
5. If *numPos* is **NaN**, let *pos* be **+∞**; otherwise, let *pos* be **ToInteger**(*numPos*).
6. Let *len* be the number of characters in *S*.
7. Let *start* be **min**(**max**(*pos*, **0**), *len*).
8. Let *searchLen* be the number of characters in *searchStr*.
9. Return the largest possible nonnegative integer *k* not larger than *start* such that *k*+ *searchLen* is not greater than *len*, and for all nonnegative integers *j* less than *searchLen*, the character at position *k*+*j* of *S* is the same as the character at position *j* of *searchStr*; but if there is no such integer *k*, then return the value **-1**.

The **length** property of the **lastIndexOf** method is **1**.

NOTE

The **lastIndexOf** function is intentionally generic; it does not require that its **this** value be a *String* object. Therefore, it can be transferred to other kinds of objects for use as a method.

15.5.4.9 **String.prototype.localeCompare** (*that*)

When the **localeCompare** method is called with one argument *that*, it returns a number other than **NaN** that represents the result of a locale-sensitive string comparison of the **this** value (converted to a string) with *that* (converted to a string). The two strings are *S* and *That*. The two strings are compared in an implementation-defined fashion. The result is intended to order strings in the sort order specified by the system default locale, and will be negative, zero, or positive, depending on whether *S* comes before *That* in the sort order, the strings are equal, or *S* comes after *That* in the sort order, respectively.

Before perform the comparisons the following steps are performed to prepare the strings:

1. Call **CheckObjectCoercible** passing the **this** value as its argument.

2. Let *S* be the result of calling ToString, giving it the **this** value as its argument.
3. Let *That* be ToString(*that*).

The **localeCompare** method, if considered as a function of two arguments **this** and *that*, is a consistent comparison function (as defined in 15.4.4.11) on the set of all strings. Furthermore, **localeCompare** returns 0 or -0 when comparing two strings that are considered canonically equivalent by the Unicode standard.

The actual return values are implementation-defined to permit implementers to encode additional information in the value, but the function is required to define a total ordering on all strings and to return 0 when comparing strings that are considered canonically equivalent by the Unicode standard.

NOTE

The **localeCompare** method itself is not directly suitable as an argument to **Array.prototype.sort** because the latter requires a function of two arguments.

This function is intended to rely on whatever language-sensitive comparison functionality is available to the ECMAScript environment from the host environment, and to compare according to the rules of the host environment's current locale. It is strongly recommended that this function treat strings that are canonically equivalent according to the Unicode standard as identical (in other words, compare the strings as if they had both been converted to Normalised Form C or D first). It is also recommended that this function not honour Unicode compatibility equivalences or decompositions.

If no language-sensitive comparison at all is available from the host environment, this function may perform a bitwise comparison.

*The **localeCompare** function is intentionally generic; it does not require that its **this** value be a String object. Therefore, it can be transferred to other kinds of objects for use as a method.*

The second parameter to this function is likely to be used in a future version of this standard; it is recommended that implementations do not use this parameter position for anything else.

15.5.4.10 String.prototype.match (regexp)

When the **match** method is called with argument *regexp*, the following steps are taken:

1. Call CheckObjectCoercible passing the **this** value as its argument.
2. Let *S* be the result of calling ToString, giving it the **this** value as its argument.
3. If Type(*regexp*) is Object and the value of the [[Class]] internal property of *regexp* is "**RegExp**", then let *rx* be *regexp*;
4. Else, let *rx* be a new RegExp object created as if by the expression **new RegExp(*regexp*)** where **RegExp** is the standard built-in constructor with that name.
5. Let *global* be the result of calling the [[Get]] internal method of *rx* with argument "**global**".
6. Let *exec* be the standard built-in function **RegExp.prototype.exec** (see 15.10.6.2)
7. If *global* is not **true**, then
 - a. Return the result of calling the [[Call]] internal method of *exec* with *rx* as the **this** value and argument list containing *S*.
8. Else, *global* is **true**
 - a. Call the [[Put]] internal method of *rx* with arguments "**lastIndex**" and 0.
 - b. Let *A* be a new array created as if by the expression **new Array()** where **Array** is the standard built-in constructor with that name.
 - c. Let *previousLastIndex* be 0.
 - d. Let *n* be 0.
 - e. Let *lastMatch* be **true**.
 - f. Repeat, while *lastMatch* is **true**
 - i. Let *result* be the result of calling the [[Call]] internal method of *exec* with *rx* as the **this** value and argument list containing *S*.
 - ii. If *result* is **null**, then set *lastMatch* to **false**.
 - iii. Else, *result* is not **null**
 1. Let *thisIndex* be the result of calling the [[Get]] internal method of *rx* with argument "**lastIndex**".
 2. If *thisIndex* = *previousLastIndex* then

- a. Call the `[[Put]]` internal method of `rx` with arguments `"lastIndex"` and `thisIndex+1`.
- b. Set `previousLastIndex` to `thisIndex+1`.
3. Else, set `previousLastIndex` to `thisIndex`.
4. Let `matchStr` be the result of calling the `[[Get]]` internal method of `result` with argument `"0"`.
5. Call the `[[DefineOwnProperty]]` internal method of `A` with arguments `ToString(n)`, the Property Descriptor `{[[Value]]: matchStr, [[Writable]]: true, [[Enumerable]]: true, [[configurable]]: true}`, and `false`.
6. Increment `n`.
- g. If `n = 0`, then return `null`.
- h. Return `A`.

NOTE

The `match` function is intentionally generic; it does not require that its `this` value be a `String` object. Therefore, it can be transferred to other kinds of objects for use as a method.

15.5.4.11 String.prototype.replace (searchValue, replaceValue)

First set `string` according to the following steps:

1. Call `CheckObjectCoercible` passing the `this` value as its argument.
2. Let `string` be the result of calling `ToString`, giving it the `this` value as its argument.

If `searchValue` is a regular expression (an object whose `[[Class]]` internal property is `"RegExp"`), do the following: If `searchValue.global` is `false`, then search `string` for the first match of the regular expression `searchValue`. If `searchValue.global` is `true`, then search `string` for all matches of the regular expression `searchValue`. Do the search in the same manner as in `String.prototype.match`, including the update of `searchValue.lastIndex`. Let `m` be the number of left capturing parentheses in `searchValue` (`NcapturingParens` as specified in 15.10.2.1).

If `searchValue` is not a regular expression, let `searchString` be `ToString(searchValue)` and search `string` for the first occurrence of `searchString`. Let `m` be 0.

If `replaceValue` is a function, then for each matched substring, call the function with the following `m + 3` arguments. Argument 1 is the substring that matched. If `searchValue` is a regular expression, the next `m` arguments are all of the captures in the `MatchResult` (see 15.10.2.1). Argument `m + 2` is the offset within `string` where the match occurred, and argument `m + 3` is `string`. The result is a string value derived from the original input by replacing each matched substring with the corresponding return value of the function call, converted to a string if need be.

Otherwise, let `newstring` denote the result of converting `replaceValue` to a string. The result is a string value derived from the original input string by replacing each matched substring with a string derived from `newstring` by replacing characters in `newstring` by replacement text as specified in the following table. These `$` replacements are done left-to-right, and, once such a replacement is performed, the new replacement text is not subject to further replacements. For example, `"$1,$2".replace(/(\$(\d))/g, "$$1-$1$2")` returns `"$1-$11,$1-$22"`. A `$` in `newstring` that does not match any of the forms below is left as is.

| <i>Characters</i> | <i>Replacement text</i> |
|----------------------|---|
| <code>\$\$</code> | <code>\$</code> |
| <code>\$&</code> | The matched substring. |
| <code>\$`</code> | The portion of <i>string</i> that precedes the matched substring. |
| <code>\$'</code> | The portion of <i>string</i> that follows the matched substring. |
| <code>\$n</code> | The <i>n</i> th capture, where <i>n</i> is a single digit 1-9 and <code>\$n</code> is not followed by a decimal digit. If $n \leq m$ and the <i>n</i> th capture is undefined , use the empty string instead. If $n > m$, the result is implementation-defined. |
| <code>\$nn</code> | The <i>nn</i> th capture, where <i>nn</i> is a two-digit decimal number 01-99. If $nn \leq m$ and the <i>nn</i> th capture is undefined , use the empty string instead. If $nn > m$, the result is implementation-defined. |

NOTE

The **replace** function is intentionally generic; it does not require that its **this** value be a *String* object. Therefore, it can be transferred to other kinds of objects for use as a method.

15.5.4.12 String.prototype.search (regexp)

When the search method is called with argument *regexp*, the following steps are taken:

1. Call CheckObjectCoercible passing the **this** value as its argument.
2. Let *string* be the result of calling ToString, giving it the **this** value as its argument.
3. If Type(*regexp*) is Object and the value of the `[[Class]]` internal property of *regexp* is **"RegExp"**, then let *rx* be *regexp*;
4. Else, let *rx* be a new RegExp object created as if by the expression `new RegExp(regexp)` where **RegExp** is the standard built-in constructor with that name.
5. Search the value *string* from its beginning for an occurrence of the regular expression pattern *rx*. Let *result* be a number indicating the offset within *string* where the pattern matched, or `-1` if there was no match. The **lastIndex** and **global** properties of *regexp* are ignored when performing the search. The **lastIndex** property of *regexp* is left unchanged.
6. Return *result*.

NOTE

The **search** function is intentionally generic; it does not require that its **this** value be a *String* object. Therefore, it can be transferred to other kinds of objects for use as a method.

15.5.4.13 String.prototype.slice (start, end)

The **slice** method takes two arguments, *start* and *end*, and returns a substring of the result of converting this object to a string, starting from character position *start* and running to, but not including, character position *end* (or through the end of the string if *end* is **undefined**). If *start* is negative, it is treated as $(sourceLength+start)$ where *sourceLength* is the length of the string. If *end* is negative, it is treated as $(sourceLength+end)$ where *sourceLength* is the length of the string. The result is a string value, not a *String* object. The following steps are taken:

1. Call CheckObjectCoercible passing the **this** value as its argument.
2. Let *S* be the result of calling ToString, giving it the **this** value as its argument.
3. Let *len* be the number of characters in *S*.
4. Let *intStart* be ToInteger(*start*).
5. If *end* is **undefined**, let *intEnd* be *len*; else let *intEnd* be ToInteger(*end*).
6. If *intStart* is negative, let *from* be $\max(len + intStart, 0)$; else let *from* be $\min(intStart, len)$.
7. If *intEnd* is negative, let *to* be $\max(len + intEnd, 0)$; else let *to* be $\min(intEnd, len)$.
8. Let *span* be $\max(to - from, 0)$.
9. Return a string containing *span* consecutive characters from *S* beginning with the character at position *from*.

The **length** property of the **slice** method is **2**.

NOTE

The `slice` function is intentionally generic; it does not require that its `this` value be a `String` object. Therefore it can be transferred to other kinds of objects for use as a method.

15.5.4.14 String.prototype.split (separator, limit)

Returns an `Array` object into which substrings of the result of converting this object to a string have been stored. The substrings are determined by searching from left to right for occurrences of `separator`; these occurrences are not part of any substring in the returned array, but serve to divide up the string value. The value of `separator` may be a string of any length or it may be a `RegExp` object (i.e., an object whose `[[Class]]` internal property is `"RegExp"`; see 15.10).

The value of `separator` may be an empty string, an empty regular expression, or a regular expression that can match an empty string. In this case, `separator` does not match the empty substring at the beginning or end of the input string, nor does it match the empty substring at the end of the previous separator match. (For example, if `separator` is the empty string, the string is split up into individual characters; the length of the result array equals the length of the string, and each substring contains one character.) If `separator` is a regular expression, only the first match at a given position of the `this` string is considered, even if backtracking could yield a non-empty-substring match at that position. (For example, `"ab".split(/a*?/)` evaluates to the array `["a", "b"]`, while `"ab".split(/a*/)` evaluates to the array `["", "b"]`.)

If the `this` object is (or converts to) the empty string, the result depends on whether `separator` can match the empty string. If it can, the result array contains no elements. Otherwise, the result array contains one element, which is the empty string.

If `separator` is a regular expression that contains capturing parentheses, then each time `separator` is matched the results (including any `undefined` results) of the capturing parentheses are spliced into the output array. For example, `"Aboldand<CODE>coded</CODE>".split(/<(\/?)([^\<]+)>/)` evaluates to the array `["A", undefined, "B", "bold", "/", "B", "and", undefined, "CODE", "coded", "/", "CODE", ""]`

If `separator` is `undefined`, then the result array contains just one string, which is the `this` value (converted to a string). If `limit` is not `undefined`, then the output array is truncated so that it contains no more than `limit` elements.

When the `split` method is called, the following steps are taken:

1. Call `CheckObjectCoercible` passing the `this` value as its argument.
2. Let `S` be the result of calling `ToString`, giving it the `this` value as its argument.
3. Let `A` be a new array created as if by the expression `new Array()` where `Array` is the standard built-in constructor with that name.
4. Let `lengthA` be 0.
5. If `limit` is `undefined`, let `lim` = $2^{32}-1$; else let `lim` = `ToUint32(limit)`.
6. Let `s` be the number of characters in `S`.
7. Let `p` = 0.
8. If `separator` is a `RegExp` object (its `[[Class]]` is `"RegExp"`), let `R` = `separator`; otherwise let `R` = `ToString(separator)`.
9. If `lim` = 0, return `A`.
10. If `separator` is `undefined`, then
 - a. Call the `[[DefineOwnProperty]]` internal method of `A` with arguments `"0"`, `Property Descriptor` `{[[Value]]: S, [[Writable]]: true, [[Enumerable]]: true, [[Configurable]]: true}`, and `false`.
 - b. Return `A`.
11. If `s` = 0, then
 - a. Call `SplitMatch(R, S, 0)` and let `z` be its `MatchResult` result.
 - b. If `z` is not `failure`, return `A`.

- c. Call the `[[DefineOwnProperty]]` internal method of *A* with arguments `"0"`, Property Descriptor `{[[Value]]: S, [[Writable]]: true, [[Enumerable]]: true, [[Configurable]]: true}`, and **false**.
 - d. Return *A*.
12. Let $q = p$.
 13. Repeat, while $q \neq s$
 - a. Call `SplitMatch(R, S, q)` and let *z* be its `MatchResult` result.
 - b. If *z* is **failure**, then let $q = q+1$.
 - c. Else, *z* is not **failure**
 - i. *z* must be a `State`. Let *e* be *z*'s `endIndex` and let *cap* be *z*'s `captures` array.
 - ii. If $e = p$, then let $q = q+1$.
 - iii. Else, $e \neq p$
 1. Let *T* be a string value equal to the substring of *S* consisting of the characters at positions *p* (inclusive) through *q* (exclusive).
 2. Call the `[[DefineOwnProperty]]` internal method of *A* with arguments `ToString(lengthA)`, Property Descriptor `{[[Value]]: T, [[Writable]]: true, [[Enumerable]]: true, [[Configurable]]: true}`, and **false**.
 3. Increment *lengthA* by 1.
 4. If $lengthA = lim$, return *A*.
 5. Let $p = e$.
 6. Let $i = 0$.
 7. Repeat, while *i* is not equal to the number of elements in *cap*.
 - a. Let $i = i+1$.
 - b. Call the `[[DefineOwnProperty]]` internal method of *A* with arguments `ToString(lengthA)`, Property Descriptor `{[[Value]]: cap[i], [[Writable]]: true, [[Enumerable]]: true, [[Configurable]]: true}`, and **false**.
 - c. Increment *lengthA* by 1.
 - d. If $A.length = lim$, return *A*.
 8. Let $q = p$.
 14. Let *T* be a string value equal to the substring of *S* consisting of the characters at positions *p* (inclusive) through *s* (exclusive).
 15. Call the `[[DefineOwnProperty]]` internal method of *A* with arguments `ToString(lengthA)`, Property Descriptor `{[[Value]]: T, [[Writable]]: true, [[Enumerable]]: true, [[Configurable]]: true}`, and **false**.
 16. Return *A*.

The abstract operation `SplitMatch` takes three parameters, a string *S*, an integer *q*, and a string or `RegExp` *R*, and performs the following in order to return a `MatchResult` (see 15.10.2.1):

1. If *R* is a `RegExp` object (its `[[Class]]` is `"RegExp"`), then
 - a. Call the `[[Match]]` internal method of *R* giving it the arguments *S* and *q*, and return the `MatchResult` result.
2. *R* must be a string. Let *r* be the number of characters in *R*.
3. Let *s* be the number of characters in *S*.
4. If $q+r > s$ then return the `MatchResult` **failure**.
5. If there exists an integer *i* between 0 (inclusive) and *r* (exclusive) such that the character at position $q+i$ of *S* is different from the character at position *i* of *R*, then return **failure**.
6. Let *cap* be an empty array of captures (see 15.10.2.1).
7. Return the `State` ($q+r$, *cap*). (see 15.10.2.1)

The `length` property of the `split` method is 2.

NOTE

The `split` function is intentionally generic; it does not require that its `this` value be a `String` object. Therefore, it can be transferred to other kinds of objects for use as a method.

The `split` method ignores the value of separator `.global` for separators that are `RegExp` objects.

15.5.4.15 **String.prototype.substring (start, end)**

The **substring** method takes two arguments, *start* and *end*, and returns a substring of the result of converting this object to a string, starting from character position *start* and running to, but not including, character position *end* of the string (or through the end of the string if *end* is **undefined**). The result is a string value, not a String object.

If either argument is **NaN** or negative, it is replaced with zero; if either argument is larger than the length of the string, it is replaced with the length of the string.

If *start* is larger than *end*, they are swapped.

The following steps are taken:

1. Call **CheckObjectCoercible** passing the **this** value as its argument.
2. Let *S* be the result of calling **ToString**, giving it the **this** value as its argument.
3. Let *len* be the number of characters in *S*.
4. Let *intStart* be **ToInteger**(*start*).
5. If *end* is **undefined**, let *intEnd* be *len*; else let *intEnd* be **ToInteger**(*end*).
6. Let *finalStart* be **min**(**max**(*intStart*, 0), *len*).
7. Let *finalEnd* be **min**(**max**(*intEnd*, 0), *len*).
8. Let *from* be **min**(*finalStart*, *finalEnd*).
9. Let *to* be **max**(*finalStart*, *finalEnd*).
10. Return a string whose length is *to* - *from*, containing characters from *S*, namely the characters with indices *from* through *to* - 1, in ascending order.

The **length** property of the **substring** method is **2**.

NOTE

*The **substring** function is intentionally generic; it does not require that its **this** value be a String object. Therefore, it can be transferred to other kinds of objects for use as a method.*

15.5.4.16 **String.prototype.toLowerCase ()**

The following steps are taken:

1. Call **CheckObjectCoercible** passing the **this** value as its argument.
2. Let *S* be the result of calling **ToString**, giving it the **this** value as its argument.
3. Let *L* be a string where each character of *L* is either the Unicode lowercase equivalent of the corresponding character of *S* or the actual corresponding character of *S* if no Unicode lowercase equivalent exists.
4. Return *L*.

NOTE

*The result should be derived according to the case mappings in the Unicode character database (this explicitly includes not only the **UnicodeData.txt** file, but also the **SpecialCasings.txt** file that accompanies it in Unicode 2.1.8 and later).*

*For the purposes of this operation, the 16-bit code units of the strings are treated as code points in the Unicode Basic Multilingual Plane. Surrogate code points are directly transferred from *S* to *L* without any mapping.*

*The case mapping of some characters may produce multiple characters. In this case the result string may not be the same length as the source string. Because both **toUpperCase** and **toLowerCase** have context-sensitive behaviour, the functions are not symmetrical. In other words, **s.toUpperCase().toLowerCase()** is not necessarily equal to **s.toLowerCase()**.*

*The **toLowerCase** function is intentionally generic; it does not require that its **this** value be a String object. Therefore, it can be transferred to other kinds of objects for use as a method.*

15.5.4.17 **String.prototype.toLocaleLowerCase ()**

This function works exactly the same as **toLowerCase** except that its result is intended to yield the correct result for the host environment's current locale, rather than a locale-independent result. There

will only be a difference in the few cases (such as Turkish) where the rules for that language conflict with the regular Unicode case mappings.

NOTE

The **toLocaleLowerCase** function is intentionally generic; it does not require that its **this** value be a *String* object. Therefore, it can be transferred to other kinds of objects for use as a method.

The first parameter to this function is likely to be used in a future version of this standard; it is recommended that implementations do not use this parameter position for anything else.

15.5.4.18 **String.prototype.toUpperCase ()**

This function behaves in exactly the same way as **String.prototype.toLowerCase**, except that characters are mapped to their *uppercase* equivalents as specified in the Unicode Character Database.

NOTE

The **toUpperCase** function is intentionally generic; it does not require that its **this** value be a *String* object. Therefore, it can be transferred to other kinds of objects for use as a method.

15.5.4.19 **String.prototype.toLocaleUpperCase ()**

This function works exactly the same as **toUpperCase** except that its result is intended to yield the correct result for the host environment's current locale, rather than a locale-independent result. There will only be a difference in the few cases (such as Turkish) where the rules for that language conflict with the regular Unicode case mappings.

NOTE

The **toLocaleUpperCase** function is intentionally generic; it does not require that its **this** value be a *String* object. Therefore, it can be transferred to other kinds of objects for use as a method.

The first parameter to this function is likely to be used in a future version of this standard; it is recommended that implementations do not use this parameter position for anything else.

15.5.4.20 **String.prototype.trim ()**

The following steps are taken:

1. Call **CheckObjectCoercible** passing the **this** value as its argument.
2. Let *S* be the result of calling **ToString**, giving it the **this** value as its argument.
3. Let *T* be a string value that is a copy of *S* with both leading and trailing white space removed. The definition of white space is the union of *WhiteSpace* and *LineTerminator*.
4. Return *T*.

NOTE

The **trim** function is intentionally generic; it does not require that its **this** value be a *String* object. Therefore, it can be transferred to other kinds of objects for use as a method.

15.5.5 **Properties of String Instances**

String instances inherit properties from the *String* prototype object and their **[[Class]]** internal property value is **"String"**. String instances also have a **[[PrimitiveValue]]** property, a **length** property, and a set of enumerable properties with array index names.

The **[[PrimitiveValue]]** internal property is the string value represented by this *String* object. The array index named properties correspond to the individual characters of the string value. A special **[[GetOwnProperty]]** internal method is used to specify the number, values, and attributes of the array index named properties.

15.5.5.1 **length**

The number of characters in the *String* value represented by this *String* object.

Once a *String* object is created, this property is unchanging. It has the attributes { **[[Writable]]**: **false**, **[[Enumerable]]**: **false**, **[[Configurable]]**: **false** }.

15.5.5.2 `[[GetOwnProperty]]` (*P*)

String objects use a variation of the `[[GetOwnProperty]]` internal method used for other native ECMAScript objects (8.12.1). This special internal method is used to specify the array index named properties of String objects.

Assume *S* is a String object and *P* is a string.

When the `[[GetOwnProperty]]` internal method of *S* is called with property name *P*, the following steps are taken:

1. Let *desc* be the result of calling the default `[[GetOwnProperty]]` internal method (8.12.1) on *S* with argument *P*.
2. If *desc* is not **undefined** return *desc*.
3. If *P* is not an array index (15.4), return **undefined**.
4. Let *str* be the String value of the `[[PrimitiveValue]]` internal property of *S*.
5. Let *index* be `ToUint32(P)`.
6. Let *len* be the number of characters in *str*.
7. If $len \leq index$, return **undefined**.
8. Let *resultStr* be a String of length 1, containing one character from *str*, specifically the character at position *index*, where the first (leftmost) character in *str* is considered to be at position 0, the next one at position 1, and so on.
9. Return a Property Descriptor { `[[Value]]`: *resultStr*, `[[Enumerable]]`: **true**, `[[Writable]]`: **false**, `[[Configurable]]`: **false** }

15.6 Boolean Objects

15.6.1 The Boolean Constructor Called as a Function

When **Boolean** is called as a function rather than as a constructor, it performs a type conversion.

15.6.1.1 Boolean (value)

Returns a boolean value (not a Boolean object) computed by `ToBoolean(value)`.

15.6.2 The Boolean Constructor

When **Boolean** is called as part of a **new** expression it is a constructor: it initialises the newly created object.

15.6.2.1 new Boolean (value)

The `[[Prototype]]` internal property of the newly constructed object is set to the original Boolean prototype object, the one that is the initial value of **Boolean.prototype** (15.6.3.1).

The `[[Class]]` internal property of the newly constructed Boolean object is set to **"Boolean"**.

The `[[PrimitiveValue]]` internal property of the newly constructed Boolean object is set to `ToBoolean(value)`.

The `[[Extensible]]` internal property of the newly constructed object is set to **true**.

15.6.3 Properties of the Boolean Constructor

The value of the `[[Prototype]]` internal property of the Boolean constructor is the Function prototype object (15.3.4).

Besides the internal properties and the **length** property (whose value is **1**), the Boolean constructor has the following property:

15.6.3.1 Boolean.prototype

The initial value of **Boolean.prototype** is the Boolean prototype object (15.6.4).

This property has the attributes { `[[Writable]]`: **false**, `[[Enumerable]]`: **false**, `[[Configurable]]`: **false** }.

15.6.4 Properties of the Boolean Prototype Object

The Boolean prototype object is itself a Boolean object (its `[[Class]]` is **"Boolean"**) whose value is **false**.

The value of the `[[Prototype]]` internal property of the Boolean prototype object is the standard built-in Object prototype object (15.2.4).

15.6.4.1 **Boolean.prototype.constructor**

The initial value of `Boolean.prototype.constructor` is the built-in `Boolean` constructor.

15.6.4.2 **Boolean.prototype.toString ()**

The following steps are taken:

1. Let *B* be the **this** value.
2. If `Type(B)` is `Boolean`, then let *b* be *B*.
3. Else if `Type(B)` is `Object` and the value of the `[[Class]]` internal property of *B* is `"Boolean"`, then let *b* be the value of the `[[PrimitiveValue]]` internal property of *B*.
4. Else throw a **TypeError** exception.
5. If *b* is `true`, then return `"true"`; else return `"false"`.

15.6.4.3 **Boolean.prototype.valueOf ()**

The following steps are taken:

1. Let *B* be the **this** value.
2. If `Type(B)` is `Boolean`, then let *b* be *B*.
3. Else if `Type(B)` is `Object` and the value of the `[[Class]]` internal property of *B* is `"Boolean"`, then let *b* be the value of the `[[PrimitiveValue]]` internal property of *B*.
4. Else throw a **TypeError** exception.
5. Return *b*.

15.6.5 **Properties of Boolean Instances**

Boolean instances inherit properties from the Boolean prototype object and their `[[Class]]` internal property value is `"Boolean"`. Boolean instances also have a `[[PrimitiveValue]]` property.

The `[[PrimitiveValue]]` internal property is the boolean value represented by this Boolean object.

15.7 **Number Objects**

15.7.1 **The Number Constructor Called as a Function**

When `Number` is called as a function rather than as a constructor, it performs a type conversion.

15.7.1.1 **Number ([value])**

Returns a number value (not a Number object) computed by `ToNumber(value)` if *value* was supplied, else returns `+0`.

15.7.2 **The Number Constructor**

When `Number` is called as part of a `new` expression it is a constructor: it initialises the newly created object.

15.7.2.1 **new Number ([value])**

The `[[Prototype]]` internal property of the newly constructed object is set to the original Number prototype object, the one that is the initial value of `Number.prototype` (15.7.3.1).

The `[[Class]]` internal property of the newly constructed object is set to `"Number"`.

The `[[PrimitiveValue]]` internal property of the newly constructed object is set to `ToNumber(value)` if *value* was supplied, else to `+0`.

The `[[Extensible]]` internal property of the newly constructed object is set to `true`.

15.7.3 **Properties of the Number Constructor**

The value of the `[[Prototype]]` internal property of the Number constructor is the Function prototype object (15.3.4).

Besides the internal properties and the `length` property (whose value is `1`), the Number constructor has the following property:

15.7.3.1 **Number.prototype**

The initial value of **Number.prototype** is the Number prototype object (15.7.4).

This property has the attributes { [[Writable]]: **false**, [[Enumerable]]: **false**, [[Configurable]]: **false** }.

15.7.3.2 **Number.MAX_VALUE**

The value of **Number.MAX_VALUE** is the largest positive finite value of the number type, which is approximately $1.7976931348623157 \times 10^{308}$.

This property has the attributes { [[Writable]]: **false**, [[Enumerable]]: **false**, [[Configurable]]: **false** }.

15.7.3.3 **Number.MIN_VALUE**

The value of **Number.MIN_VALUE** is the smallest positive value of the number type, which is approximately 5×10^{-324} .

This property has the attributes { [[Writable]]: **false**, [[Enumerable]]: **false**, [[Configurable]]: **false** }.

15.7.3.4 **Number.NaN**

The value of **Number.NaN** is NaN.

This property has the attributes { [[Writable]]: **false**, [[Enumerable]]: **false**, [[Configurable]]: **false** }.

15.7.3.5 **Number.NEGATIVE_INFINITY**

The value of **Number.NEGATIVE_INFINITY** is $-\infty$.

This property has the attributes { [[Writable]]: **false**, [[Enumerable]]: **false**, [[Configurable]]: **false** }.

15.7.3.6 **Number.POSITIVE_INFINITY**

The value of **Number.POSITIVE_INFINITY** is $+\infty$.

This property has the attributes { [[Writable]]: **false**, [[Enumerable]]: **false**, [[Configurable]]: **false** }.

15.7.4 **Properties of the Number Prototype Object**

The Number prototype object is itself a Number object (its [[Class]] is "**Number**") whose value is +0.

The value of the [[Prototype]] internal property of the Number prototype object is the standard built-in Object prototype object (15.2.4).

Unless explicitly stated otherwise, the methods of the Number prototype object defined in this section are not generic and the this value passed to them must be either a Number value or an Object for which the value of the [[Class]] internal property is "**Number**".

In the following descriptions of functions that are properties of the Number prototype object, the phrase "this Number object" refers to either the object that is the **this** value for the invocation of the function or, if Type(**this** value) is Number, an object that is created as if by the expression **new Number (this value)** where **Number** is the standard built-in constructor with that name. Also, the phrase "this number value" refers to either the number value represented by this Number object, that is, the value of the [[PrimitiveValue]] internal property of this Number object or the **this** value if its type is Number. A **TypeError** exception is thrown if the **this** value is neither an object for which the value of the [[Class]] internal property is "**Number**" or a value whose type is Number.

15.7.4.1 **Number.prototype.constructor**

The initial value of **Number.prototype.constructor** is the built-in **Number** constructor.

15.7.4.2 **Number.prototype.toString ([radix])**

The optional *radix* should be an integer value in the inclusive range 2 to 36. If *radix* not present or is **undefined** the number 10 is used as the value of *radix*. If ToInteger(*radix*) is the number 10 then this number value is given as an argument to the ToString abstract operation; the resulting string value is returned.

If ToInteger(*radix*) is not an integer between 2 and 36 inclusive throw a RangeError exception. If ToInteger(*radix*) is an integer from 2 to 36, but not 10, the result is a string representation of this number value using the specified radix. Letters **a-z** are used for digits with values 10 through 35. The

precise algorithm is implementation-dependent if the radix is not 10, however the algorithm should be a generalization of that specified in 9.8.1.

The **toString** function is not generic; it throws a **TypeError** exception if its **this** value is not a Number or a Number object. Therefore, it cannot be transferred to other kinds of objects for use as a method.

15.7.4.3 **Number.prototype.toLocaleString()**

Produces a string value that represents this Number value formatted according to the conventions of the host environment's current locale. This function is implementation-dependent, and it is permissible, but not encouraged, for it to return the same thing as **toString**.

NOTE

The first parameter to this function is likely to be used in a future version of this standard; it is recommended that implementations do not use this parameter position for anything else.

15.7.4.4 **Number.prototype.valueOf()**

Returns this number value.

The **valueOf** function is not generic; it throws a **TypeError** exception if its **this** value is not a Number or a Number object. Therefore, it cannot be transferred to other kinds of objects for use as a method.

15.7.4.5 **Number.prototype.toFixed(fractionDigits)**

Return a string containing the number represented in fixed-point notation with *fractionDigits* digits after the decimal point. If *fractionDigits* is **undefined**, 0 is assumed. Specifically, perform the following steps:

1. Let *f* be **ToInteger**(*fractionDigits*). (If *fractionDigits* is **undefined**, this step produces the value 0).
2. If $f < 0$ or $f > 20$, throw a **RangeError** exception.
3. Let *x* be this number value.
4. If *x* is **NaN**, return the string **"NaN"**.
5. Let *s* be the empty string.
6. If $x < 0$, then
 - a. Let *s* be "-".
 - b. Let $x = -x$.
7. If $x \geq 10^{21}$, then
 - a. Let $m = \text{ToString}(x)$.
8. Else, $x < 10^{21}$
 - a. Let *n* be an integer for which the exact mathematical value of $n \div 10^f - x$ is as close to zero as possible. If there are two such *n*, pick the larger *n*.
 - b. If $n = 0$, let *m* be the string **"0"**. Otherwise, let *m* be the string consisting of the digits of the decimal representation of *n* (in order, with no leading zeroes).
 - c. If $f \neq 0$, then
 - i. Let *k* be the number of characters in *m*.
 - ii. If $k \leq f$, then
 1. Let *z* be the string consisting of $f+1-k$ occurrences of the character '0'.
 2. Let *m* be the concatenation of strings *z* and *m*.
 3. Let $k = f + 1$.
 - iii. Let *a* be the first $k-f$ characters of *m*, and let *b* be the remaining *f* characters of *m*.
 - iv. Let *m* be the concatenation of the three strings *a*, ".", and *b*.
9. Return the concatenation of the strings *s* and *m*.

The **length** property of the **toFixed** method is 1.

If the **toFixed** method is called with more than one argument, then the behaviour is undefined (see clause 15).

An implementation is permitted to extend the behaviour of **toFixed** for values of *fractionDigits* less than 0 or greater than 20. In this case **toFixed** would not necessarily throw **RangeError** for such values.

NOTE

The output of **toFixed** may be more precise than **toString** for some values because **toString** only prints enough significant digits to distinguish the number from adjacent number values. For example, `(1000000000000000000128).toString()` returns `"1000000000000000100"`, while `(1000000000000000000128).toFixed(0)` returns `"1000000000000000128"`.

15.7.4.6 **Number.prototype.toExponential (fractionDigits)**

Return a string containing the number represented in exponential notation with one digit before the significand's decimal point and *fractionDigits* digits after the significand's decimal point. If *fractionDigits* is **undefined**, include as many significand digits as necessary to uniquely specify the number (just like in **ToString** except that in this case the number is always output in exponential notation). Specifically, perform the following steps:

1. Let *x* be this number value.
2. Let *f* be **ToInteger**(*fractionDigits*).
3. If *x* is **NaN**, return the string `"NaN"`.
4. Let *s* be the empty string.
5. If *x* < 0, then
 - a. Let *s* be `"-"`.
 - b. Let *x* = $-x$.
6. If *x* = $+\infty$, then
 - a. Return the concatenation of the strings *s* and `"Infinity"`.
7. If *fractionDigits* is not **undefined** and (*f* < 0 or *f* > 20), throw a **RangeError** exception.
8. If *x* = 0, then
 - a. Let *f* = 0.
 - b. Let *m* be the string consisting of *f*+1 occurrences of the character `'0'`.
 - c. Let *e* = 0.
9. Else, *x* ≠ 0
 - a. If *fractionDigits* is not **undefined**, then
 - i. Let *e* and *n* be integers such that $10^f \leq n < 10^{f+1}$ and for which the exact mathematical value of $n \times 10^{e-f} - x$ is as close to zero as possible. If there are two such sets of *e* and *n*, pick the *e* and *n* for which $n \times 10^{e-f}$ is larger.
 - b. Else, *fractionDigits* is **undefined**
 - i. Let *e*, *n*, and *f* be integers such that $f \geq 0$, $10^f \leq n < 10^{f+1}$, the number value for $n \times 10^{e-f}$ is *x*, and *f* is as small as possible. Note that the decimal representation of *n* has *f*+1 digits, *n* is not divisible by 10, and the least significant digit of *n* is not necessarily uniquely determined by these criteria.
 - c. Let *m* be the string consisting of the digits of the decimal representation of *n* (in order, with no leading zeroes).
 - b. Let *m* be the string consisting of the digits of the decimal representation of *x* (in order, with no leading zeroes).
10. If *f* ≠ 0, then
 - a. Let *a* be the first character of *m*, and let *b* be the remaining *f* characters of *m*.
 - b. Let *m* be the concatenation of the three strings *a*, `"."`, and *b*.
11. If *e* = 0, then
 - a. Let *c* = `"+"`.
 - b. Let *d* = `"0"`.
12. Else
 - a. If *e* > 0, then let *c* = `"+"`.
 - b. Else, *e* ≤ 0
 - i. Let *c* = `"-"`.
 - ii. Let *e* = $-e$.
 - c. Let *d* be the string consisting of the digits of the decimal representation of *e* (in order, with no leading zeroes).
13. Let *m* be the concatenation of the four strings *m*, `"e"`, *c*, and *d*.

14. Return the concatenation of the strings s and m .

The **length** property of the **toExponential** method is **1**.

If the **toExponential** method is called with more than one argument, then the behaviour is undefined (see clause 15).

An implementation is permitted to extend the behaviour of **toExponential** for values of *fractionDigits* less than 0 or greater than 20. In this case **toExponential** would not necessarily throw **RangeError** for such values.

NOTE

For implementations that provide more accurate conversions than required by the rules above, it is recommended that the following alternative version of step 9.b.i be used as a guideline:

Let e , n , and f be integers such that $f \geq 0$, $10^f \leq n < 10^{f+1}$, the number value for $n \times 10^{e-f}$ is x , and f is as small as possible. If there are multiple possibilities for n , choose the value of n for which $n \times 10^{e-f}$ is closest in value to x . If there are two such possible values of n , choose the one that is even.

15.7.4.7 **Number.prototype.toPrecision (precision)**

Return a string containing the number represented either in exponential notation with one digit before the significand's decimal point and *precision*–1 digits after the significand's decimal point or in fixed notation with *precision* significant digits. If *precision* is **undefined**, call ToString (9.8.1) instead. Specifically, perform the following steps:

1. Let x be this number value.
2. If *precision* is **undefined**, return ToString(x).
3. Let p be ToInteger(*precision*).
4. If x is **NaN**, return the string "**NaN**".
5. Let s be the empty string.
6. If $x < 0$, then
 - a. Let s be "-".
 - b. Let $x = -x$.
7. If $x = +\infty$, then
 - a. Return the concatenation of the strings s and "**Infinity**".
8. If $p < 1$ or $p > 21$, throw a **RangeError** exception.
9. If $x = 0$, then
 - a. Let m be the string consisting of p occurrences of the character '0'.
 - b. Let $e = 0$.
10. Else $x \neq 0$,
 - a. Let e and n be integers such that $10^{p-1} \leq n < 10^p$ and for which the exact mathematical value of $n \times 10^{e-p+1} - x$ is as close to zero as possible. If there are two such sets of e and n , pick the e and n for which $n \times 10^{e-p+1}$ is larger.
 - b. Let m be the string consisting of the digits of the decimal representation of n (in order, with no leading zeroes).
 - c. If $e < -6$ or $e \geq p$, then
 - i. Let a be the first character of m , and let b be the remaining $p-1$ characters of m .
 - ii. Let m be the concatenation of the three strings a , ".", and b .
 - iii. If $e = 0$, then
 1. Let $c = "+"$ and $d = "0"$.
 - iv. Else $e \neq 0$,
 1. If $e > 0$, then
 - a. Let $c = "+"$.
 2. Else $e < 0$,
 - a. Let $c = "-"$.
 - b. Let $e = -e$.
 3. Let d be the string consisting of the digits of the decimal representation of e (in order, with no leading zeroes).
 - v. Let m be the concatenation of the five strings s , m , "**e**", c , and d .

11. If $e = p-1$, then return the concatenation of the strings s and m .
12. If $e \geq 0$, then
 - a. Let m be the concatenation of the first $e+1$ characters of m , the character ‘.’, and the remaining $p-(e+1)$ characters of m .
13. Else $e < 0$,
 - a. Let m be the concatenation of the string "0.", $-(e+1)$ occurrences of the character ‘0’, and the string m .
14. Return the concatenation of the strings s and m .

The **length** property of the **toPrecision** method is **1**.

If the **toPrecision** method is called with more than one argument, then the behaviour is undefined (see clause 15).

An implementation is permitted to extend the behaviour of **toPrecision** for values of *precision* less than 1 or greater than 21. In this case **toPrecision** would not necessarily throw **RangeError** for such values.

15.7.5 Properties of Number Instances

Number instances inherit properties from the Number prototype object and their **[[Class]]** internal property value is "**Number**". Number instances also have a **[[PrimitiveValue]]** property.

The **[[PrimitiveValue]]** internal property is the number value represented by this Number object.

15.8 The Math Object

The Math object is a single object that has some named properties, some of which are functions.

The value of the **[[Prototype]]** internal property of the Math object is the standard built-in Object prototype object (15.2.4). The value of the **[[Class]]** internal property of the Math object is "**Math**".

The Math object does not have a **[[Construct]]** internal property; it is not possible to use the Math object as a constructor with the **new** operator.

The Math object does not have a **[[Call]]** internal property; it is not possible to invoke the Math object as a function.

NOTE

In this specification, the phrase “the number value for x ” has a technical meaning defined in 8.5.

15.8.1 Value Properties of the Math Object

15.8.1.1 E

The number value for e , the base of the natural logarithms, which is approximately 2.7182818284590452354.

This property has the attributes { **[[Writable]]**: **false**, **[[Enumerable]]**: **false**, **[[Configurable]]**: **false** }.

15.8.1.2 LN10

The number value for the natural logarithm of 10, which is approximately 2.302585092994046.

This property has the attributes { **[[Writable]]**: **false**, **[[Enumerable]]**: **false**, **[[Configurable]]**: **false** }.

15.8.1.3 LN2

The number value for the natural logarithm of 2, which is approximately 0.6931471805599453.

This property has the attributes { **[[Writable]]**: **false**, **[[Enumerable]]**: **false**, **[[Configurable]]**: **false** }.

15.8.1.4 LOG2E

The number value for the base-2 logarithm of e , the base of the natural logarithms; this value is approximately 1.4426950408889634.

This property has the attributes { **[[Writable]]**: **false**, **[[Enumerable]]**: **false**, **[[Configurable]]**: **false** }.

NOTE

*The value of **Math.LOG2E** is approximately the reciprocal of the value of **Math.LN2**.*

15.8.1.5 LOG10E

The number value for the base-10 logarithm of e , the base of the natural logarithms; this value is approximately 0.4342944819032518.

This property has the attributes { [[Writable]]: **false**, [[Enumerable]]: **false**, [[Configurable]]: **false** }.

NOTE

The value of **Math.LOG10E** is approximately the reciprocal of the value of **Math.LN10**.

15.8.1.6 PI

The number value for π , the ratio of the circumference of a circle to its diameter, which is approximately 3.1415926535897932.

This property has the attributes { [[Writable]]: **false**, [[Enumerable]]: **false**, [[Configurable]]: **false** }.

15.8.1.7 SQRT1_2

The number value for the square root of 1/2, which is approximately 0.7071067811865476.

This property has the attributes { [[Writable]]: **false**, [[Enumerable]]: **false**, [[Configurable]]: **false** }.

NOTE

The value of **Math.SQRT1_2** is approximately the reciprocal of the value of **Math.SQRT2**.

15.8.1.8 SQRT2

The number value for the square root of 2, which is approximately 1.4142135623730951.

This property has the attributes { [[Writable]]: **false**, [[Enumerable]]: **false**, [[Configurable]]: **false** }.

15.8.2 Function Properties of the Math Object

Every function listed in this section applies the ToNumber operator to each of its arguments (in left-to-right order if there is more than one) and then performs a computation on the resulting number value(s).

In the function descriptions below, the symbols NaN, -0, +0, $-\infty$ and $+\infty$ refer to the number values described in 8.5.

NOTE

The behaviour of the functions **acos**, **asin**, **atan**, **atan2**, **cos**, **exp**, **log**, **pow**, **sin**, and **sqrt** is not precisely specified here except to require specific results for certain argument values that represent boundary cases of interest. For other argument values, these functions are intended to compute approximations to the results of familiar mathematical functions, but some latitude is allowed in the choice of approximation algorithms. The general intent is that an implementer should be able to use the same mathematical library for ECMAScript on a given hardware platform that is available to C programmers on that platform.

Although the choice of algorithms is left to the implementation, it is recommended (but not specified by this standard) that implementations use the approximation algorithms for IEEE 754 arithmetic contained in **fdlibm**, the freely distributable mathematical library from Sun Microsystems (<http://www.netlib.org/fdlibm>).

15.8.2.1 abs (x)

Returns the absolute value of x ; the result has the same magnitude as x but has positive sign.

- If x is NaN, the result is NaN.
- If x is -0, the result is +0.
- If x is $-\infty$, the result is $+\infty$.

15.8.2.2 acos (x)

Returns an implementation-dependent approximation to the arc cosine of x . The result is expressed in radians and ranges from +0 to $+\pi$.

- If x is NaN, the result is NaN.
- If x is greater than 1, the result is NaN.

- If x is less than -1 , the result is NaN.
- If x is exactly 1 , the result is $+0$.

15.8.2.3 **asin** (x)

Returns an implementation-dependent approximation to the arc sine of x . The result is expressed in radians and ranges from $-\pi/2$ to $+\pi/2$.

- If x is NaN, the result is NaN.
- If x is greater than 1 , the result is NaN.
- If x is less than -1 , the result is NaN.
- If x is $+0$, the result is $+0$.
- If x is -0 , the result is -0 .

15.8.2.4 **atan** (x)

Returns an implementation-dependent approximation to the arc tangent of x . The result is expressed in radians and ranges from $-\pi/2$ to $+\pi/2$.

- If x is NaN, the result is NaN.
- If x is $+0$, the result is $+0$.
- If x is -0 , the result is -0 .
- If x is $+\infty$, the result is an implementation-dependent approximation to $+\pi/2$.
- If x is $-\infty$, the result is an implementation-dependent approximation to $-\pi/2$.

15.8.2.5 **atan2** (y, x)

Returns an implementation-dependent approximation to the arc tangent of the quotient y/x of the arguments y and x , where the signs of y and x are used to determine the quadrant of the result. Note that it is intentional and traditional for the two-argument arc tangent function that the argument named y be first and the argument named x be second. The result is expressed in radians and ranges from $-\pi$ to $+\pi$.

- If either x or y is NaN, the result is NaN.
- If $y > 0$ and x is $+0$, the result is an implementation-dependent approximation to $+\pi/2$.
- If $y > 0$ and x is -0 , the result is an implementation-dependent approximation to $+\pi/2$.
- If y is $+0$ and $x > 0$, the result is $+0$.
- If y is $+0$ and x is $+0$, the result is $+0$.
- If y is $+0$ and x is -0 , the result is an implementation-dependent approximation to $+\pi$.
- If y is $+0$ and $x < 0$, the result is an implementation-dependent approximation to $+\pi$.
- If y is -0 and $x > 0$, the result is -0 .
- If y is -0 and x is $+0$, the result is -0 .
- If y is -0 and x is -0 , the result is an implementation-dependent approximation to $-\pi$.
- If y is -0 and $x < 0$, the result is an implementation-dependent approximation to $-\pi$.
- If $y < 0$ and x is $+0$, the result is an implementation-dependent approximation to $-\pi/2$.
- If $y < 0$ and x is -0 , the result is an implementation-dependent approximation to $-\pi/2$.
- If $y > 0$ and y is finite and x is $+\infty$, the result is $+0$.
- If $y > 0$ and y is finite and x is $-\infty$, the result is an implementation-dependent approximation to $+\pi$.
- If $y < 0$ and y is finite and x is $+\infty$, the result is -0 .
- If $y < 0$ and y is finite and x is $-\infty$, the result is an implementation-dependent approximation to $-\pi$.
- If y is $+\infty$ and x is finite, the result is an implementation-dependent approximation to $+\pi/2$.
- If y is $-\infty$ and x is finite, the result is an implementation-dependent approximation to $-\pi/2$.
- If y is $+\infty$ and x is $+\infty$, the result is an implementation-dependent approximation to $+\pi/4$.
- If y is $+\infty$ and x is $-\infty$, the result is an implementation-dependent approximation to $+3\pi/4$.

- If y is $-\infty$ and x is $+\infty$, the result is an implementation-dependent approximation to $-\pi/4$.
- If y is $-\infty$ and x is $-\infty$, the result is an implementation-dependent approximation to $-3\pi/4$.

15.8.2.6 **ceil (x)**

Returns the smallest (closest to $-\infty$) number value that is not less than x and is equal to a mathematical integer. If x is already an integer, the result is x .

- If x is NaN, the result is NaN.
- If x is $+0$, the result is $+0$.
- If x is -0 , the result is -0 .
- If x is $+\infty$, the result is $+\infty$.
- If x is $-\infty$, the result is $-\infty$.
- If x is less than 0 but greater than -1 , the result is -0 .

The value of `Math.ceil(x)` is the same as the value of `-Math.floor(-x)`.

15.8.2.7 **cos (x)**

Returns an implementation-dependent approximation to the cosine of x . The argument is expressed in radians.

- If x is NaN, the result is NaN.
- If x is $+0$, the result is 1.
- If x is -0 , the result is 1.
- If x is $+\infty$, the result is NaN.
- If x is $-\infty$, the result is NaN.

15.8.2.8 **exp (x)**

Returns an implementation-dependent approximation to the exponential function of x (e raised to the power of x , where e is the base of the natural logarithms).

- If x is NaN, the result is NaN.
- If x is $+0$, the result is 1.
- If x is -0 , the result is 1.
- If x is $+\infty$, the result is $+\infty$.
- If x is $-\infty$, the result is $+0$.

15.8.2.9 **floor (x)**

Returns the greatest (closest to $+\infty$) number value that is not greater than x and is equal to a mathematical integer. If x is already an integer, the result is x .

- If x is NaN, the result is NaN.
- If x is $+0$, the result is $+0$.
- If x is -0 , the result is -0 .
- If x is $+\infty$, the result is $+\infty$.
- If x is $-\infty$, the result is $-\infty$.
- If x is greater than 0 but less than 1, the result is $+0$.

NOTE

The value of `Math.floor(x)` is the same as the value of `-Math.ceil(-x)`.

15.8.2.10 **log (x)**

Returns an implementation-dependent approximation to the natural logarithm of x .

- If x is NaN, the result is NaN.

- If x is less than 0, the result is NaN.
- If x is +0 or -0, the result is $-\infty$.
- If x is 1, the result is +0.
- If x is $+\infty$, the result is $+\infty$.

15.8.2.11 **max** ([value1 [, value2 [, ...]]])

Given zero or more arguments, calls ToNumber on each of the arguments and returns the largest of the resulting values.

- If no arguments are given, the result is $-\infty$.
- If any value is NaN, the result is NaN.
- The comparison of values to determine the largest value is done as in 11.8.5 except that +0 is considered to be larger than -0.

The **length** property of the **max** method is 2.

15.8.2.12 **min** ([value1 [, value2 [, ...]]])

Given zero or more arguments, calls ToNumber on each of the arguments and returns the smallest of the resulting values.

- If no arguments are given, the result is $+\infty$.
- If any value is NaN, the result is NaN.
- The comparison of values to determine the smallest value is done as in 11.8.5 except that +0 is considered to be larger than -0.

The **length** property of the **min** method is 2.

15.8.2.13 **pow** (x , y)

Returns an implementation-dependent approximation to the result of raising x to the power y .

- If y is NaN, the result is NaN.
- If y is +0, the result is 1, even if x is NaN.
- If y is -0, the result is 1, even if x is NaN.
- If x is NaN and y is nonzero, the result is NaN.
- If $\text{abs}(x) > 1$ and y is $+\infty$, the result is $+\infty$.
- If $\text{abs}(x) > 1$ and y is $-\infty$, the result is +0.
- If $\text{abs}(x) == 1$ and y is $+\infty$, the result is NaN.
- If $\text{abs}(x) == 1$ and y is $-\infty$, the result is NaN.
- If $\text{abs}(x) < 1$ and y is $+\infty$, the result is +0.
- If $\text{abs}(x) < 1$ and y is $-\infty$, the result is $+\infty$.
- If x is $+\infty$ and $y > 0$, the result is $+\infty$.
- If x is $+\infty$ and $y < 0$, the result is +0.
- If x is $-\infty$ and $y > 0$ and y is an odd integer, the result is $-\infty$.
- If x is $-\infty$ and $y > 0$ and y is not an odd integer, the result is $+\infty$.
- If x is $-\infty$ and $y < 0$ and y is an odd integer, the result is -0.
- If x is $-\infty$ and $y < 0$ and y is not an odd integer, the result is +0.
- If x is +0 and $y > 0$, the result is +0.
- If x is +0 and $y < 0$, the result is $+\infty$.
- If x is -0 and $y > 0$ and y is an odd integer, the result is -0.
- If x is -0 and $y > 0$ and y is not an odd integer, the result is +0.
- If x is -0 and $y < 0$ and y is an odd integer, the result is $-\infty$.
- If x is -0 and $y < 0$ and y is not an odd integer, the result is $+\infty$.

- If $x < 0$ and x is finite and y is finite and y is not an integer, the result is NaN.

15.8.2.14 **random ()**

Returns a number value with positive sign, greater than or equal to 0 but less than 1, chosen randomly or pseudo randomly with approximately uniform distribution over that range, using an implementation-dependent algorithm or strategy. This function takes no arguments.

15.8.2.15 **round (x)**

Returns the number value that is closest to x and is equal to a mathematical integer. If two integer number values are equally close to x , then the result is the number value that is closer to $+\infty$. If x is already an integer, the result is x .

- If x is NaN, the result is NaN.
- If x is $+0$, the result is $+0$.
- If x is -0 , the result is -0 .
- If x is $+\infty$, the result is $+\infty$.
- If x is $-\infty$, the result is $-\infty$.
- If x is greater than 0 but less than 0.5, the result is $+0$.
- If x is less than 0 but greater than or equal to -0.5 , the result is -0 .

NOTE

Math.round(3.5) returns 4, but Math.round(-3.5) returns -3.

*The value of **Math.round(x)** is the same as the value of **Math.floor(x+0.5)**, except when x is -0 or is less than 0 but greater than or equal to -0.5 ; for these cases **Math.round(x)** returns -0 , but **Math.floor(x+0.5)** returns $+0$.*

15.8.2.16 **sin (x)**

Returns an implementation-dependent approximation to the sine of x . The argument is expressed in radians.

- If x is NaN, the result is NaN.
- If x is $+0$, the result is $+0$.
- If x is -0 , the result is -0 .
- If x is $+\infty$ or $-\infty$, the result is NaN.

15.8.2.17 **sqrt (x)**

Returns an implementation-dependent approximation to the square root of x .

- If x is NaN, the result is NaN.
- If x is less than 0, the result is NaN.
- If x is $+0$, the result is $+0$.
- If x is -0 , the result is -0 .
- If x is $+\infty$, the result is $+\infty$.

15.8.2.18 **tan (x)**

Returns an implementation-dependent approximation to the tangent of x . The argument is expressed in radians.

- If x is NaN, the result is NaN.
- If x is $+0$, the result is $+0$.
- If x is -0 , the result is -0 .
- If x is $+\infty$ or $-\infty$, the result is NaN.

15.9 Date Objects

15.9.1 Overview of Date Objects and Definitions of Internal Operators

A Date object contains a number indicating a particular instant in time to within a millisecond. Such a number is called a *time value*. A time value may also be **NaN**, indicating that the Date object does not represent a specific instant of time.

The following sections define a number of functions for operating on time values. Note that, in every case, if any argument to such a function is **NaN**, the result will be **NaN**.

15.9.1.1 Time Values and Time Range

Time is measured in ECMAScript in milliseconds since 01 January, 1970 UTC. In time values leap seconds are ignored. It is assumed that there are exactly 86,400,000 milliseconds per day. ECMAScript number values can represent all integers from $-9,007,199,254,740,991$ to $9,007,199,254,740,991$; this range suffices to measure times to millisecond precision for any instant that is within approximately 285,616 years, either forward or backward, from 01 January, 1970 UTC.

The actual range of times supported by ECMAScript Date objects is slightly smaller: exactly $-100,000,000$ days to $100,000,000$ days measured relative to midnight at the beginning of 01 January, 1970 UTC. This gives a range of 8,640,000,000,000,000 milliseconds to either side of 01 January, 1970 UTC.

The exact moment of midnight at the beginning of 01 January, 1970 UTC is represented by the value **+0**.

15.9.1.2 Day Number and Time within Day

A given time value t belongs to day number

$$\text{Day}(t) = \text{floor}(t / \text{msPerDay})$$

where the number of milliseconds per day is

$$\text{msPerDay} = 86400000$$

The remainder is called the time within the day:

$$\text{TimeWithinDay}(t) = t \text{ modulo } \text{msPerDay}$$

15.9.1.3 Year Number

ECMAScript uses an extrapolated Gregorian system to map a day number to a year number and to determine the month and date within that year. In this system, leap years are precisely those which are (divisible by 4) and ((not divisible by 100) or (divisible by 400)). The number of days in year number y is therefore defined by

$$\begin{aligned} \text{DaysInYear}(y) &= 365 \text{ if } (y \text{ modulo } 4) \neq 0 \\ &= 366 \text{ if } (y \text{ modulo } 4) = 0 \text{ and } (y \text{ modulo } 100) \neq 0 \\ &= 365 \text{ if } (y \text{ modulo } 100) = 0 \text{ and } (y \text{ modulo } 400) \neq 0 \\ &= 366 \text{ if } (y \text{ modulo } 400) = 0 \end{aligned}$$

All non-leap years have 365 days with the usual number of days per month and leap years have an extra day in February. The day number of the first day of year y is given by:

$$\text{DayFromYear}(y) = 365 \times (y-1970) + \text{floor}((y-1969)/4) - \text{floor}((y-1901)/100) + \text{floor}((y-1601)/400)$$

The time value of the start of a year is:

$$\text{TimeFromYear}(y) = \text{msPerDay} \times \text{DayFromYear}(y)$$

A time value determines a year by:

$$\text{YearFromTime}(t) = \text{the largest integer } y \text{ (closest to positive infinity) such that } \text{TimeFromYear}(y) \leq t$$

The leap-year function is 1 for a time within a leap year and otherwise is zero:

InLeapYear(t) = 0 if DaysInYear(YearFromTime(t)) = 365
= 1 if DaysInYear(YearFromTime(t)) = 366

15.9.1.4 Month Number

Months are identified by an integer in the range 0 to 11, inclusive. The mapping MonthFromTime(t) from a time value t to a month number is defined by:

| | | | |
|--------------------------|----|-----------------------|---|
| MonthFromTime(t) = 0 | if | 0 | \leq DayWithinYear(t) < 31 |
| = 1 | if | 31 | \leq DayWithinYear(t) < 59+InLeapYear(t) |
| = 2 | if | 59+InLeapYear(t) | \leq DayWithinYear(t) < 90+InLeapYear(t) |
| = 3 | if | 90+InLeapYear(t) | \leq DayWithinYear(t) < 120+InLeapYear(t) |
| = 4 | if | 120+InLeapYear(t) | \leq DayWithinYear(t) < 151+InLeapYear(t) |
| = 5 | if | 151+InLeapYear(t) | \leq DayWithinYear(t) < 181+InLeapYear(t) |
| = 6 | if | 181+InLeapYear(t) | \leq DayWithinYear(t) < 212+InLeapYear(t) |
| = 7 | if | 212+InLeapYear(t) | \leq DayWithinYear(t) < 243+InLeapYear(t) |
| = 8 | if | 243+InLeapYear(t) | \leq DayWithinYear(t) < 273+InLeapYear(t) |
| = 9 | if | 273+InLeapYear(t) | \leq DayWithinYear(t) < 304+InLeapYear(t) |
| = 10 | if | 304+InLeapYear(t) | \leq DayWithinYear(t) < 334+InLeapYear(t) |
| = 11 | if | 334+InLeapYear(t) | \leq DayWithinYear(t) < 365+InLeapYear(t) |

where

DayWithinYear(t) = Day(t) – DayFromYear(YearFromTime(t))

A month value of 0 specifies January; 1 specifies February; 2 specifies March; 3 specifies April; 4 specifies May; 5 specifies June; 6 specifies July; 7 specifies August; 8 specifies September; 9 specifies October; 10 specifies November; and 11 specifies December. Note that MonthFromTime(0) = 0, corresponding to Thursday, 01 January, 1970.

15.9.1.5 Date Number

A date number is identified by an integer in the range 1 through 31, inclusive. The mapping DateFromTime(t) from a time value t to a month number is defined by:

| | |
|--|----------------------------|
| DateFromTime(t) = DayWithinYear(t)+1 | if MonthFromTime(t)=0 |
| = DayWithinYear(t)–30 | if MonthFromTime(t)=1 |
| = DayWithinYear(t)–58–InLeapYear(t) | if MonthFromTime(t)=2 |
| = DayWithinYear(t)–89–InLeapYear(t) | if MonthFromTime(t)=3 |
| = DayWithinYear(t)–119–InLeapYear(t) | if MonthFromTime(t)=4 |
| = DayWithinYear(t)–150–InLeapYear(t) | if MonthFromTime(t)=5 |
| = DayWithinYear(t)–180–InLeapYear(t) | if MonthFromTime(t)=6 |
| = DayWithinYear(t)–211–InLeapYear(t) | if MonthFromTime(t)=7 |
| = DayWithinYear(t)–242–InLeapYear(t) | if MonthFromTime(t)=8 |
| = DayWithinYear(t)–272–InLeapYear(t) | if MonthFromTime(t)=9 |
| = DayWithinYear(t)–303–InLeapYear(t) | if MonthFromTime(t)=10 |
| = DayWithinYear(t)–333–InLeapYear(t) | if MonthFromTime(t)=11 |

15.9.1.6 Week Day

The weekday for a particular time value t is defined as

WeekDay(t) = (Day(t) + 4) modulo 7

A weekday value of 0 specifies Sunday; 1 specifies Monday; 2 specifies Tuesday; 3 specifies Wednesday; 4 specifies Thursday; 5 specifies Friday; and 6 specifies Saturday. Note that WeekDay(0) = 4, corresponding to Thursday, 01 January, 1970.

15.9.1.7 Local Time Zone Adjustment

An implementation of ECMAScript is expected to determine the local time zone adjustment. The local time zone adjustment is a value LocalTZA measured in milliseconds which when added to UTC represents the local *standard* time. Daylight saving time is *not* reflected by LocalTZA. The value LocalTZA does not vary with time but depends only on the geographic location.

15.9.1.8 Daylight Saving Time Adjustment

An implementation of ECMAScript is expected to determine the daylight saving time algorithm. The algorithm to determine the daylight saving time adjustment $\text{DaylightSavingTA}(t)$, measured in milliseconds, must depend only on four things:

(1) the time since the beginning of the year

$$t - \text{TimeFromYear}(\text{YearFromTime}(t))$$

(2) whether t is in a leap year

$$\text{InLeapYear}(t)$$

(3) the week day of the beginning of the year

$$\text{WeekDay}(\text{TimeFromYear}(\text{YearFromTime}(t)))$$

and (4) the geographic location.

The implementation of ECMAScript should not try to determine whether the exact time was subject to daylight saving time, but just whether daylight saving time would have been in effect if the current daylight saving time algorithm had been used at the time. This avoids complications such as taking into account the years that the locale observed daylight saving time year round.

If the host environment provides functionality for determining daylight saving time, the implementation of ECMAScript is free to map the year in question to an equivalent year (same leap-year-ness and same starting week day for the year) for which the host environment provides daylight saving time information. The only restriction is that all equivalent years should produce the same result.

15.9.1.9 Local Time

Conversion from UTC to local time is defined by

$$\text{LocalTime}(t) = t + \text{LocalTZA} + \text{DaylightSavingTA}(t)$$

Conversion from local time to UTC is defined by

$$\text{UTC}(t) = t - \text{LocalTZA} - \text{DaylightSavingTA}(t - \text{LocalTZA})$$

Note that $\text{UTC}(\text{LocalTime}(t))$ is not necessarily always equal to t .

15.9.1.10 Hours, Minutes, Second, and Milliseconds

The following functions are useful in decomposing time values:

$$\text{HourFromTime}(t) = \text{floor}(t / \text{msPerHour}) \text{ modulo } \text{HoursPerDay}$$

$$\text{MinFromTime}(t) = \text{floor}(t / \text{msPerMinute}) \text{ modulo } \text{MinutesPerHour}$$

$$\text{SecFromTime}(t) = \text{floor}(t / \text{msPerSecond}) \text{ modulo } \text{SecondsPerMinute}$$

$$\text{msFromTime}(t) = t \text{ modulo } \text{msPerSecond}$$

where

$$\text{HoursPerDay} = 24$$

$$\text{MinutesPerHour} = 60$$

$$\text{SecondsPerMinute} = 60$$

$$\text{msPerSecond} = 1000$$

$$\text{msPerMinute} = \text{msPerSecond} \times \text{SecondsPerMinute} = 60000$$

$$\text{msPerHour} = \text{msPerMinute} \times \text{MinutesPerHour} = 3600000$$

15.9.1.11 MakeTime (hour, min, sec, ms)

The operator `MakeTime` calculates a number of milliseconds from its four arguments, which must be ECMAScript number values. This operator functions as follows:

1. If *hour* is not finite or *min* is not finite or *sec* is not finite or *ms* is not finite, return **NaN**.
2. Let *h* be `ToInteger(hour)`.
3. Let *m* be `ToInteger(min)`.
4. Let *s* be `ToInteger(sec)`.
5. Let *milli* be `ToInteger(ms)`.
6. Let *t* be $h * \text{msPerHour} + m * \text{msPerMinute} + s * \text{msPerSecond} + \text{milli}$, performing the arithmetic according to IEEE 754 rules (that is, as if using the ECMAScript operators `*` and `+`).
7. Return *t*.

15.9.1.12 **MakeDay (year, month, date)**

The operator `MakeDay` calculates a number of days from its three arguments, which must be ECMAScript number values. This operator functions as follows:

1. If *year* is not finite or *month* is not finite or *date* is not finite, return **NaN**.
2. Let *y* be `ToInteger(year)`.
3. Let *m* be `ToInteger(month)`.
4. Let *dt* be `ToInteger(date)`.
5. Let *ym* be $y + \text{floor}(m / 12)$.
6. Let *mn* be *m* modulo 12.
7. Find a value *t* such that `YearFromTime(t) == ym` and `MonthFromTime(t) == mn` and `DateFromTime(t) == 1`; but if this is not possible (because some argument is out of range), return **NaN**.
8. Return `Day(t) + dt - 1`.

15.9.1.13 **MakeDate (day, time)**

The operator `MakeDate` calculates a number of milliseconds from its two arguments, which must be ECMAScript number values. This operator functions as follows:

1. If *day* is not finite or *time* is not finite, return **NaN**.
2. Return $\text{day} \times \text{msPerDay} + \text{time}$.

15.9.1.14 **TimeClip (time)**

The operator `TimeClip` calculates a number of milliseconds from its argument, which must be an ECMAScript number value. This operator functions as follows:

1. If *time* is not finite, return **NaN**.
2. If $\text{abs}(time) > 8.64 \times 10^{15}$, return **NaN**.
3. Return an implementation-dependent choice of either `ToInteger(time)` or `ToInteger(time) + (+0)`. (Adding a positive zero converts `-0` to `+0`.)

NOTE

The point of step 3 is that an implementation is permitted a choice of internal representations of time values, for example as a 64-bit signed integer or as a 64-bit floating-point value. Depending on the implementation, this internal representation may or may not distinguish `-0` and `+0`.

15.9.1.15 **Date Time String Format**

ECMAScript defines a string interchange format for date-times based upon a simplification of the ISO 8601 Extended Format. The format is as follows: **YYYY-MM-DDT^THH:mm:ss.sssZ**

Where the fields are as follows:

YYYY is the decimal digits of the year in the Gregorian calendar.

MM is the month of the year from 01 (January) to 12 (December).

DD is the day of the month from 01 to 31.

The “**T**” appears literally in the string, to indicate the beginning of the time element.

HH is the number of complete hours that have passed since midnight as two decimal digits.

mm is the number of complete minutes since the start of the hour as two decimal digits.

ss is the number of complete seconds since the start of the minute as two decimal digits.

The “.” (dot) appears literally in the string.

sss is the number of complete milliseconds since the start of the second as three decimal digits.

Both the “.” and the milliseconds field may be omitted.

z is the time zone offset specified as “**z**” (for UTC) or either “+” or “-” followed by a time expression **hh:mm**

Extended years

ECMAScript requires the ability to specify 6 digit years (extended years); approximately 285,616 years, either forward or backward, from 01 January, 1970 UTC. To represent years before 0 or after 9999, ISO 8601 permits the expansion of the year representation, but only by prior agreement between the sender and the receiver. In the simplified ECMAScript format such an expanded year representation shall have 2 extra year digits and is always prefixed with a + or - sign with the convention that year 0 is positive.

NOTE

This format includes date-only forms:

YYYY

YYYY-MM

YYYY-MM-DD

It also includes time-only forms with an optional time zone offset appended:

THH:mm

THH:mm:ss

THH:mm:ss.sss

Also included are “date-times” which could be any combination of the above.

All numbers must be base 10.

Illegal values (out-of-bounds as well as syntax errors) in a format string means that the format string is not a valid instance of this format.

As every day both starts and ends with midnight, the two notations 00:00 and 24:00 are available to distinguish the two midnights that can be associated with one date. This means that the following two notations refer to exactly the same point in time: 1995-02-04T24:00 and 1995-02-05T00:00

There exists no international standard that specifies abbreviations for civil time zones like CET, EST, etc. and sometimes the same abbreviation is even used for two very different time zones. For this reason, ISO 8601 and this format specifies numeric representations of date and time.

15.9.2 The Date Constructor Called as a Function

When **Date** is called as a function rather than as a constructor, it returns a string representing the current time (UTC).

NOTE

*The function call **Date (...)** is not equivalent to the object creation expression **new Date (...)** with the same arguments.*

15.9.2.1 **Date** ([year [, month [, date [, hours [, minutes [, seconds [, ms]]]]]]])

All of the arguments are optional; any arguments supplied are accepted but are completely ignored. A string is created and returned as if by the expression **(new Date()).toString()** where **Date** is the standard built-in constructor with that name and **toString** is the standard built-in method **Date.prototype.toString**.

15.9.3 The Date Constructor

When **Date** is called as part of a **new** expression, it is a constructor: it initialises the newly created object.

15.9.3.1 **new Date (year, month [, date [, hours [, minutes [, seconds [, ms]]]]])**

When **Date** is called with two to seven arguments, it computes the date from *year*, *month*, and (optionally) *date*, *hours*, *minutes*, *seconds* and *ms*.

The `[[Prototype]]` internal property of the newly constructed object is set to the original Date prototype object, the one that is the initial value of **Date.prototype** (15.9.4.1).

The `[[Class]]` internal property of the newly constructed object is set to **"Date"**.

The `[[Extensible]]` internal property of the newly constructed object is set to **true**.

The `[[PrimitiveValue]]` internal property of the newly constructed object is set as follows:

1. Let *y* be `ToNumber(year)`.
2. Let *m* be `ToNumber(month)`.
3. If *date* is supplied then let *dt* be `ToNumber(date)`; else let *dt* be **1**.
4. If *hours* is supplied then let *h* be `ToNumber(hours)`; else let *h* be **0**.
5. If *minutes* is supplied then let *min* be `ToNumber(minutes)`; else let *min* be **0**.
6. If *seconds* is supplied then let *s* be `ToNumber(seconds)`; else let *s* be **0**.
7. If *ms* is supplied then let *milli* be `ToNumber(ms)`; else let *milli* be **0**.
8. If *y* is not **NaN** and $0 \leq \text{ToInteger}(y) \leq 99$, then let *yr* be $1900 + \text{ToInteger}(y)$; otherwise, let *yr* be *y*.
9. Let *finalDate* be `MakeDate(MakeDay(yr, m, dt), MakeTime(h, min, s, milli))`.
10. Set the `[[PrimitiveValue]]` internal property of the newly constructed object to `TimeClip(UTC(finalDate))`.

15.9.3.2 **new Date (value)**

The `[[Prototype]]` internal property of the newly constructed object is set to the original Date prototype object, the one that is the initial value of **Date.prototype** (15.9.4.1).

The `[[Class]]` internal property of the newly constructed object is set to **"Date"**.

The `[[Extensible]]` internal property of the newly constructed object is set to **true**.

The `[[PrimitiveValue]]` internal property of the newly constructed object is set as follows:

1. Let *v* be `ToPrimitive(value)`.
2. If `Type(v)` is **String**, then
 - a. Parse *v* as a date, in exactly the same manner as for the **parse** method (15.9.4.2); let *V* be the time value for this date.
3. Else, let *V* be `ToNumber(v)`.
4. Set the `[[PrimitiveValue]]` internal property of the newly constructed object to `TimeClip(V)` and return.

15.9.3.3 **new Date ()**

The `[[Prototype]]` internal property of the newly constructed object is set to the original Date prototype object, the one that is the initial value of **Date.prototype** (15.9.4.1).

The `[[Class]]` internal property of the newly constructed object is set to **"Date"**.

The `[[Extensible]]` internal property of the newly constructed object is set to **true**.

The `[[PrimitiveValue]]` internal property of the newly constructed object is set to the time value (UTC) identifying the current time.

15.9.4 **Properties of the Date Constructor**

The value of the `[[Prototype]]` internal property of the Date constructor is the Function prototype object (15.3.4).

Besides the internal properties and the **length** property (whose value is **7**), the Date constructor has the following properties:

15.9.4.1 **Date.prototype**

The initial value of **Date.prototype** is the built-in Date prototype object (15.9.5).

This property has the attributes { [[Writable]]: **false**, [[Enumerable]]: **false**, [[Configurable]]: **false** }.

15.9.4.2 **Date.parse (string)**

The **parse** function applies the **ToString** operator to its argument and interprets the resulting string as a date and time; it returns a number, the UTC time value corresponding to the date and time. The string may be interpreted as a local time, a UTC time, or a time in some other time zone, depending on the contents of the string. The function first attempts to parse the format of the string according to the rules called out in Date Time String Format (15.9.1.15). If the string does not conform to that format the function may fall back to any implementation-specific heuristics or implementation-specific date formats. Unrecognizable strings or dates containing illegal element values in the format string shall cause **Date.parse** to return NaN.

If *x* is any Date object whose milliseconds amount is zero within a particular implementation of ECMAScript, then all of the following expressions should produce the same numeric value in that implementation, if all the properties referenced have their initial values:

x.valueOf()

Date.parse(x.toString())

Date.parse(x.toUTCString())

Date.parse(x.toISOString())

However, the expression

Date.parse(x.toLocaleString())

is not required to produce the same number value as the preceding three expressions and, in general, the value produced by **Date.parse** is implementation-dependent when given any string value that does not conform to the Date Time String Format (15.9.1.15) and that could not be produced in that implementation by the **toString** or **toUTCString** method.

15.9.4.3 **Date.UTC (year, month [, date [, hours [, minutes [, seconds [, ms]]]]])**

When the **UTC** function is called with fewer than two arguments, the behaviour is implementation-dependent. When the **UTC** function is called with two to seven arguments, it computes the date from *year*, *month* and (optionally) *date*, *hours*, *minutes*, *seconds* and *ms*. The following steps are taken:

1. Let *y* be **ToNumber**(*year*).
2. Let *m* be **ToNumber**(*month*).
3. If *date* is supplied then let *dt* be **ToNumber**(*date*); else let *dt* be **1**.
4. If *hours* is supplied then let *h* be **ToNumber**(*hours*); else let *h* be **0**.
5. If *minutes* is supplied then let *min* be **ToNumber**(*minutes*); else let *min* be **0**.
6. If *seconds* is supplied then let *s* be **ToNumber**(*seconds*); else let *s* be **0**.
7. If *ms* is supplied then let *milli* be **ToNumber**(*ms*); else let *milli* be **0**.
8. If *y* is not **NaN** and $0 \leq \text{ToInteger}(y) \leq 99$, then let *yr* be $1900 + \text{ToInteger}(y)$; otherwise, let *yr* be *y*.
9. Return **TimeClip**(**MakeDate**(**MakeDay**(*yr*, *m*, *dt*), **MakeTime**(*h*, *min*, *s*, *milli*))).

The **length** property of the **UTC** function is **7**.

NOTE

The UTC function differs from the Date constructor in two ways: it returns a time value as a number, rather than creating a Date object, and it interprets the arguments in UTC rather than as local time.

15.9.4.4 **Date.now ()**

The **now** function return a Number value that is the time value designating the UTC date and time of the occurrence of the call to **now**.

15.9.5 **Properties of the Date Prototype Object**

The Date prototype object is itself a Date object (its [[Class]] is "**Date**") whose [[PrimitiveValue]] is **NaN**.

The value of the `[[Prototype]]` internal property of the Date prototype object is the standard built-in Object prototype object (15.2.4).

In following descriptions of functions that are properties of the Date prototype object, the phrase “this Date object” refers to the object that is the **this** value for the invocation of the function. None of these functions are generic; a **TypeError** exception is thrown if the **this** value is not an object for which the value of the `[[Class]]` internal property is **"Date"**. Also, the phrase “this time value” refers to the number value for the time represented by this Date object, that is, the value of the `[[PrimitiveValue]]` internal property of this Date object.

15.9.5.1 **Date.prototype.constructor**

The initial value of **Date.prototype.constructor** is the built-in **Date** constructor.

15.9.5.2 **Date.prototype.toString ()**

This function returns a string value. The contents of the string are implementation-dependent, but are intended to represent the Date in the current time zone in a convenient, human-readable form.

NOTE

For any Date value d whose milliseconds amount is zero, the result of `Date.parse(d.toString())` is equal to `d.valueOf()`. See section 15.9.4.2.

15.9.5.3 **Date.prototype.toDateString ()**

This function returns a string value. The contents of the string are implementation-dependent, but are intended to represent the “date” portion of the Date in the current time zone in a convenient, human-readable form.

15.9.5.4 **Date.prototype.toTimeString ()**

This function returns a string value. The contents of the string are implementation-dependent, but are intended to represent the “time” portion of the Date in the current time zone in a convenient, human-readable form.

15.9.5.5 **Date.prototype.toLocaleString ()**

This function returns a string value. The contents of the string are implementation-dependent, but are intended to represent the Date in the current time zone in a convenient, human-readable form that corresponds to the conventions of the host environment’s current locale.

NOTE

The first parameter to this function is likely to be used in a future version of this standard; it is recommended that implementations do not use this parameter position for anything else.

15.9.5.6 **Date.prototype.toLocaleDateString ()**

This function returns a string value. The contents of the string are implementation-dependent, but are intended to represent the “date” portion of the Date in the current time zone in a convenient, human-readable form that corresponds to the conventions of the host environment’s current locale.

NOTE

The first parameter to this function is likely to be used in a future version of this standard; it is recommended that implementations do not use this parameter position for anything else.

15.9.5.7 **Date.prototype.toLocaleTimeString ()**

This function returns a string value. The contents of the string are implementation-dependent, but are intended to represent the “time” portion of the Date in the current time zone in a convenient, human-readable form that corresponds to the conventions of the host environment’s current locale.

NOTE

The first parameter to this function is likely to be used in a future version of this standard; it is recommended that implementations do not use this parameter position for anything else.

15.9.5.8 **Date.prototype.valueOf ()**

The **valueOf** function returns a number, which is this time value.

- 15.9.5.9 Date.prototype.getTime ()**
1. Return this time value.
- 15.9.5.10 Date.prototype.getFullYear ()**
1. Let *t* be this time value.
 2. If *t* is **NaN**, return **NaN**.
 3. Return YearFromTime(LocalTime(*t*)).
- 15.9.5.11 Date.prototype.getUTCFullYear ()**
1. Let *t* be this time value.
 2. If *t* is **NaN**, return **NaN**.
 3. Return YearFromTime(*t*).
- 15.9.5.12 Date.prototype.getMonth ()**
1. Let *t* be this time value.
 2. If *t* is **NaN**, return **NaN**.
 3. Return MonthFromTime(LocalTime(*t*)).
- 15.9.5.13 Date.prototype.getUTCMonth ()**
1. Let *t* be this time value.
 2. If *t* is **NaN**, return **NaN**.
 3. Return MonthFromTime(*t*).
- 15.9.5.14 Date.prototype.getDate ()**
1. Let *t* be this time value.
 2. If *t* is **NaN**, return **NaN**.
 3. Return DateFromTime(LocalTime(*t*)).
- 15.9.5.15 Date.prototype.getUTCDate ()**
1. Let *t* be this time value.
 2. If *t* is **NaN**, return **NaN**.
 3. Return DateFromTime(*t*).
- 15.9.5.16 Date.prototype.getDay ()**
1. Let *t* be this time value.
 2. If *t* is **NaN**, return **NaN**.
 3. Return WeekDay(LocalTime(*t*)).
- 15.9.5.17 Date.prototype.getUTCDay ()**
1. Let *t* be this time value.
 2. If *t* is **NaN**, return **NaN**.
 3. Return WeekDay(*t*).
- 15.9.5.18 Date.prototype.getHours ()**
1. Let *t* be this time value.
 2. If *t* is **NaN**, return **NaN**.
 3. Return HourFromTime(LocalTime(*t*)).
- 15.9.5.19 Date.prototype.getUTCHours ()**
1. Let *t* be this time value.
 2. If *t* is **NaN**, return **NaN**.
 3. Return HourFromTime(*t*).
- 15.9.5.20 Date.prototype.getMinutes ()**
1. Let *t* be this time value.

2. If t is NaN, return NaN.
3. Return `MinFromTime(LocalTime(t))`.

15.9.5.21 Date.prototype.getUTCMinutes ()

1. Let t be this time value.
2. If t is NaN, return NaN.
3. Return `MinFromTime(t)`.

15.9.5.22 Date.prototype.getSeconds ()

1. Let t be this time value.
2. If t is NaN, return NaN.
3. Return `SecFromTime(LocalTime(t))`.

15.9.5.23 Date.prototype.getUTCSeconds ()

1. Let t be this time value.
2. If t is NaN, return NaN.
3. Return `SecFromTime(t)`.

15.9.5.24 Date.prototype.getMilliseconds ()

1. Let t be this time value.
2. If t is NaN, return NaN.
3. Return `msFromTime(LocalTime(t))`.

15.9.5.25 Date.prototype.getUTCMilliseconds ()

1. Let t be this time value.
2. If t is NaN, return NaN.
3. Return `msFromTime(t)`.

15.9.5.26 Date.prototype.getTimezoneOffset ()

Returns the difference between local time and UTC time in minutes.

1. Let t be this time value.
2. If t is NaN, return NaN.
3. Return $(t - \text{LocalTime}(t)) / \text{msPerMinute}$.

15.9.5.27 Date.prototype.setTime (time)

1. Let v be `TimeClip(ToNumber($time$))`.
2. Set the `[[PrimitiveValue]]` internal property of this Date object to v .
3. Return v .

15.9.5.28 Date.prototype.setMilliseconds (ms)

1. Let t be the result of `LocalTime(this time value)`.
2. Let $time$ be `MakeTime(HourFromTime(t), MinFromTime(t), SecFromTime(t), ToNumber(ms))`.
3. Let u be `TimeClip(UTC(MakeDate(Day(t), $time$)))`.
4. Set the `[[PrimitiveValue]]` internal property of this Date object to u .
5. Return u .

15.9.5.29 Date.prototype.setUTCMilliseconds (ms)

1. Let t be this time value.
2. Let $time$ be `MakeTime(HourFromTime(t), MinFromTime(t), SecFromTime(t), ToNumber(ms))`.
3. Let v be `TimeClip(MakeDate(Day(t), $time$))`.
4. Set the `[[PrimitiveValue]]` internal property of this Date object to v .
5. Return v .

15.9.5.30 Date.prototype.setSeconds (sec [, ms])

If ms is not specified, this behaves as if ms were specified with the value `getMilliseconds()`.

1. Let *t* be the result of `LocalTime(this time value)`.
2. Let *s* be `ToNumber(sec)`.
3. If *ms* is not specified, then let *milli* be `msFromTime(t)`; otherwise, let *milli* be `ToNumber(ms)`.
4. Let *date* be `MakeDate(Day(t), MakeTime(HourFromTime(t), MinFromTime(t), s, milli))`.
5. Let *u* be `TimeClip(UTC(date))`.
6. Set the `[[PrimitiveValue]]` internal property of this Date object to *u*.
7. Return *u*.

The **length** property of the **setSeconds** method is **2**.

15.9.5.31 **Date.prototype.setUTCSeconds (sec [, ms])**

If *ms* is not specified, this behaves as if *ms* were specified with the value `getUTCMilliseconds()`.

1. Let *t* be this time value.
2. Let *s* be `ToNumber(sec)`.
3. If *ms* is not specified, then let *milli* be `msFromTime(t)`; otherwise, let *milli* be `ToNumber(ms)`.
4. Let *date* be `MakeDate(Day(t), MakeTime(HourFromTime(t), MinFromTime(t), s, milli))`.
5. Let *v* be `TimeClip(date)`.
6. Set the `[[PrimitiveValue]]` internal property of this Date object to *v*.
7. Return *v*.

The **length** property of the **setUTCSeconds** method is **2**.

15.9.5.33 **Date.prototype.setMinutes (min [, sec [, ms]])**

If *sec* is not specified, this behaves as if *sec* were specified with the value `getSeconds()`.

If *ms* is not specified, this behaves as if *ms* were specified with the value `getMilliseconds()`.

1. Let *t* be the result of `LocalTime(this time value)`.
2. Let *m* be `ToNumber(min)`.
3. If *sec* is not specified, then let *s* be `SecFromTime(t)`; otherwise, let *s* be `ToNumber(sec)`.
4. If *ms* is not specified, then let *milli* be `msFromTime(t)`; otherwise, let *milli* be `ToNumber(ms)`.
5. Let *date* be `MakeDate(Day(t), MakeTime(HourFromTime(t), m, s, milli))`.
6. Let *u* be `TimeClip(UTC(date))`.
7. Set the `[[PrimitiveValue]]` internal property of this Date object to *u*.
8. Return *u*.

The **length** property of the **setMinutes** method is **3**.

15.9.5.34 **Date.prototype.setUTCMinutes (min [, sec [, ms]])**

If *sec* is not specified, this behaves as if *sec* were specified with the value `getUTCSeconds()`.

If *ms* is not specified, this function behaves as if *ms* were specified with the value return by `getUTCMilliseconds()`.

1. Let *t* be this time value.
2. Let *m* be `ToNumber(min)`.
3. If *sec* is not specified, then let *s* be `SecFromTime(t)`; otherwise, let *s* be `ToNumber(sec)`.
4. If *ms* is not specified, then let *milli* be `msFromTime(t)`; otherwise, let *milli* be `ToNumber(ms)`.
5. Let *date* be `MakeDate(Day(t), MakeTime(HourFromTime(t), m, s, milli))`.
6. Let *v* be `TimeClip(date)`.
7. Set the `[[PrimitiveValue]]` internal property of this Date object to *v*.
8. Return *v*.

The **length** property of the **setUTCMinutes** method is **3**.

15.9.5.35 **Date.prototype.setHours (hour [, min [, sec [, ms]]])**

If *min* is not specified, this behaves as if *min* were specified with the value `getMinutes()`.

If *sec* is not specified, this behaves as if *sec* were specified with the value `getSeconds()`.

If *ms* is not specified, this behaves as if *ms* were specified with the value `getMilliseconds()`.

1. Let *t* be the result of `LocalTime`(this time value).
2. Let *h* be `ToNumber(hour)`.
3. If *min* is not specified, then let *m* be `MinFromTime(t)`; otherwise, let *m* be `ToNumber(min)`.
4. If *sec* is not specified, then let *s* be `SecFromTime(t)`; otherwise, let *s* be `ToNumber(sec)`.
5. If *ms* is not specified, then let *milli* be `msFromTime(t)`; otherwise, let *milli* be `ToNumber(ms)`.
6. Let *date* be `MakeDate(Day(t), MakeTime(h, m, s, milli))`.
7. Let *u* be `TimeClip(UTC(date))`.
8. Set the `[[PrimitiveValue]]` internal property of this Date object to *u*.
9. Return *u*.

The `length` property of the `setHours` method is 4.

15.9.5.36 `Date.prototype.setUTCHours` (`hour` [, `min` [, `sec` [, `ms`]]])

If *min* is not specified, this behaves as if *min* were specified with the value `getUTCMinutes()`.

If *sec* is not specified, this behaves as if *sec* were specified with the value `getUTCSeconds()`.

If *ms* is not specified, this behaves as if *ms* were specified with the value `getUTCMilliseconds()`.

1. Let *t* be this time value.
2. Let *h* be `ToNumber(hour)`.
3. If *min* is not specified, then let *m* be `MinFromTime(t)`; otherwise, let *m* be `ToNumber(min)`.
4. If *sec* is not specified, then let *s* be `SecFromTime(t)`; otherwise, let *s* be `ToNumber(sec)`.
5. If *ms* is not specified, then let *milli* be `msFromTime(t)`; otherwise, let *milli* be `ToNumber(ms)`.
6. Let *newDate* be `MakeDate(Day(t), MakeTime(h, m, s, milli))`.
7. Let *v* be `TimeClip(newDate)`.
8. Set the `[[PrimitiveValue]]` internal property of this Date object to *v*.
9. Return *v*.

The `length` property of the `setUTCHours` method is 4.

15.9.5.37 `Date.prototype.setDate` (`date`)

1. Let *t* be the result of `LocalTime`(this time value).
2. Let *dt* be `ToNumber(date)`.
3. Let *newDate* be `MakeDate(MakeDay(YearFromTime(t), MonthFromTime(t), dt), TimeWithinDay(t))`.
4. Let *u* be `TimeClip(UTC(newDate))`.
5. Set the `[[PrimitiveValue]]` internal property of this Date object to *u*.
6. Return *u*.

15.9.5.38 `Date.prototype.setUTCDate` (`date`)

1. Let *t* be this time value.
2. Let *dt* be `ToNumber(date)`.
3. Let *newDate* be `MakeDate(MakeDay(YearFromTime(t), MonthFromTime(t), dt), TimeWithinDay(t))`.
4. Let *v* be `TimeClip(newDate)`.
5. Set the `[[PrimitiveValue]]` internal property of this Date object to *v*.
6. Return *v*.

15.9.5.39 `Date.prototype.setMonth` (`month` [, `date`])

If *date* is not specified, this behaves as if *date* were specified with the value `getDate()`.

1. Let *t* be the result of `LocalTime`(this time value).
2. Let *m* be `ToNumber(month)`.
3. If *date* is not specified, then let *dt* be `DateFromTime(t)`; otherwise, let *dt* be `ToNumber(date)`.
4. Let *newDate* be `MakeDate(MakeDay(YearFromTime(t), m, dt), TimeWithinDay(t))`.
5. Let *u* be `TimeClip(UTC(newDate))`.
6. Set the `[[PrimitiveValue]]` internal property of this Date object to *u*.
7. Return *u*.

The **length** property of the **setMonth** method is **2**.

15.9.5.40 **Date.prototype.setUTCMonth** (*month* [, *date*])

If *date* is not specified, this behaves as if *date* were specified with the value `getUTCDate()`.

1. Let *t* be this time value.
2. Let *m* be `ToNumber(month)`.
3. If *date* is not specified, then let *dt* be `DateFromTime(t)`; otherwise, let *dt* be `ToNumber(date)`.
4. Let *newDate* be `MakeDate(MakeDay(YearFromTime(t), m, dt), TimeWithinDay(t))`.
5. Let *v* be `TimeClip(newDate)`.
6. Set the `[[PrimitiveValue]]` internal property of this Date object to *v*.
7. Return *v*.

The **length** property of the **setUTCMonth** method is **2**.

15.9.5.41 **Date.prototype.setFullYear** (*year* [, *month* [, *date*]])

If *month* is not specified, this behaves as if *month* were specified with the value `getMonth()`.

If *date* is not specified, this behaves as if *date* were specified with the value `getDate()`.

1. Let *t* be the result of `LocalTime(this time value)`; but if this time value is **NaN**, let *t* be **+0**.
2. Let *y* be `ToNumber(year)`.
3. If *month* is not specified, then let *m* be `MonthFromTime(t)`; otherwise, let *m* be `ToNumber(month)`.
4. If *date* is not specified, then let *dt* be `DateFromTime(t)`; otherwise, let *dt* be `ToNumber(date)`.
5. Let *newDate* be `MakeDate(MakeDay(y, m, dt), TimeWithinDay(t))`.
6. Let *u* be `TimeClip(UTC(newDate))`.
7. Set the `[[PrimitiveValue]]` internal property of this Date object to *u*.
8. Return *u*.

The **length** property of the **setFullYear** method is **3**.

15.9.5.42 **Date.prototype.setUTCFullYear** (*year* [, *month* [, *date*]])

If *month* is not specified, this behaves as if *month* were specified with the value `getUTCMonth()`.

If *date* is not specified, this behaves as if *date* were specified with the value `getUTCDate()`.

1. Let *t* be this time value; but if this time value is **NaN**, let *t* be **+0**.
2. Let *y* be `ToNumber(year)`.
3. If *month* is not specified, then let *m* be `MonthFromTime(t)`; otherwise, let *m* be `ToNumber(month)`.
4. If *date* is not specified, then let *dt* be `DateFromTime(t)`; otherwise, let *dt* be `ToNumber(date)`.
5. Let *newDate* be `MakeDate(MakeDay(y, m, dt), TimeWithinDay(t))`.
6. Let *v* be `TimeClip(newDate)`.
7. Set the `[[PrimitiveValue]]` internal property of this Date object to *v*.
8. Return *v*.

The **length** property of the **setUTCFullYear** method is **3**.

15.9.5.43 **Date.prototype.toUTCString** ()

This function returns a string value. The contents of the string are implementation-dependent, but are intended to represent the Date in a convenient, human-readable form in UTC.

NOTE

The intent is to produce a string representation of a date that is more readable than the format specified in Section 15.9.1.15. It is not essential that the chosen format be unambiguous or easily machine parsable. If an implementation does not have a preferred human-readable format it is recommended to use the format called out in Section 15.9.1.15 but with a space rather than a “T” used to separate the date and time elements.

15.9.5.44 Date.prototype.toISOString ()

This function returns a string value represent the instance in time represented by this Date object. The format of the string is as called out in Date Time string format (15.9.1.15). All fields are present in the string. The time zone is always UTC, denoted by the suffix Z. If the time value of this object is not a finite number a **RangeError** exception is thrown.

15.9.5.45 Date.prototype.toJSON (key)

This function provides a string representation of a Date object for use by JSON.stringify (15.12.3)..

When the toJSON method is called with argument key, the following steps are taken:

1. Let *O* be the result of calling ToObject, giving it the **this** value as its argument.
2. Let *tv* be ToPrimitive(*O*, hint Number).
3. If *tv* is a Number and is not finite, return **null**.
4. Let *toISO* be the result of calling the [[Get]] internal method of *O* with argument "**toISOString**".
5. If IsCallable(*toISO*) is **false**, throw a **TypeError** exception.
6. Let *result* be the result of calling the [[Call]] internal method of *toISO* with *O* as the **this** value and an empty argument list.
7. If *result* is a primitive value, return *result*.
8. Else, throw a **TypeError** exception.

NOTE

The argument is ignored.

*The **toJSON** function is intentionally generic; it does not require that its **this** value be a Date object. Therefore, it can be transferred to other kinds of objects for use as a method. However, it does require that any such object have a **toISOString** method. An object is free to use the argument 'key' that is passed in to filter its stringification.*

15.9.6 Properties of Date Instances

Date instances inherit properties from the Date prototype object and their [[Class]] internal property value is "**Date**". Date instances also have a [[PrimitiveValue]] property.

The [[PrimitiveValue]] internal property is time value represented by this Date object.

15.10 RegExp (Regular Expression) Objects

A RegExp object contains a regular expression and the associated flags.

NOTE

The form and functionality of regular expressions is modelled after the regular expression facility in the Perl 5 programming language.

15.10.1 Patterns

The **RegExp** constructor applies the following grammar to the input pattern string. An error occurs if the grammar cannot interpret the string as an expansion of *Pattern*.

Syntax

Pattern ::

Disjunction

Disjunction ::

Alternative

Alternative | *Disjunction*

Alternative ::

[empty]

Alternative Term

Term ::
 Assertion
 Atom
 Atom Quantifier

Assertion ::
 ^
 \$
 \ b
 \ B
 (? = *Disjunction*)
 (? ! *Disjunction*)

Quantifier ::
 QuantifierPrefix
 QuantifierPrefix ?

QuantifierPrefix ::
 *
 +
 ?
 { *DecimalDigits* }
 { *DecimalDigits* , }
 { *DecimalDigits* , *DecimalDigits* }

Atom ::
 PatternCharacter
 .
 \ *AtomEscape*
 CharacterClass
 (*Disjunction*)
 (? : *Disjunction*)

PatternCharacter :: *SourceCharacter* but not any of:
 ^ \$ \ . * + ? () [] { } |

AtomEscape ::
 DecimalEscape
 CharacterEscape
 CharacterClassEscape

CharacterEscape ::
 ControlEscape
 c *ControlLetter*
 HexEscapeSequence
 UnicodeEscapeSequence
 IdentityEscape

ControlEscape :: **one of**
 f n r t v

ControlLetter :: **one of**
 a b c d e f g h i j k l m n o p q r s t u v w x y z
 A B C D E F G H I J K L M N O P Q R S T U V W X Y Z

IdentityEscape ::

SourceCharacter **but not** *IdentifierPart*

<ZWJ>

<ZWJ>

DecimalEscape ::

DecimalIntegerLiteral [lookahead \notin *DecimalDigit*]

CharacterClassEscape :: **one of**

d D s S w W

CharacterClass ::

[[lookahead \notin {^}] *ClassRanges*]

[^ *ClassRanges*]

ClassRanges ::

[empty]

NonemptyClassRanges

NonemptyClassRanges ::

ClassAtom

ClassAtom NonemptyClassRangesNoDash

ClassAtom - ClassAtom ClassRanges

NonemptyClassRangesNoDash ::

ClassAtom

ClassAtomNoDash NonemptyClassRangesNoDash

ClassAtomNoDash - ClassAtom ClassRanges

ClassAtom ::

-

ClassAtomNoDash

ClassAtomNoDash ::

SourceCharacter **but not one of** \] -

\ *ClassEscape*

ClassEscape ::

DecimalEscape

b

CharacterEscape

CharacterClassEscape

15.10.2 Pattern Semantics

A regular expression pattern is converted into an internal procedure using the process described below. An implementation is encouraged to use more efficient algorithms than the ones listed below, as long as the results are the same. The internal procedure is used as the value of a RegExp object's `[[Match]]` internal property.

15.10.2.1 Notation

The descriptions below use the following variables:

- *Input* is the string being matched by the regular expression pattern. The notation *input*[*n*] means the *n*th character of *input*, where *n* can range between 0 (inclusive) and *InputLength* (exclusive).
- *InputLength* is the number of characters in the *Input* string.
- *NcapturingParens* is the total number of left capturing parentheses (i.e. the total number of times the *Atom* :: (*Disjunction*) production is expanded) in the pattern. A left capturing parenthesis is

any (pattern character that is matched by the (terminal of the *Atom* :: (*Disjunction*) production.

- *IgnoreCase* is the setting of the RegExp object's **ignoreCase** property.
- *Multiline* is the setting of the RegExp object's **multiline** property.

Furthermore, the descriptions below use the following internal data structures:

- A *CharSet* is a *mathematical* set of characters.
- A *State* is an ordered pair (*endIndex*, *captures*) where *endIndex* is an integer and *captures* is an internal array of *NcapturingParens* values. States are used to represent partial match states in the regular expression matching algorithms. The *endIndex* is one plus the index of the last input character matched so far by the pattern, while *captures* holds the results of capturing parentheses. The *n*th element of *captures* is either a string that represents the value obtained by the *n*th set of capturing parentheses or **undefined** if the *n*th set of capturing parentheses hasn't been reached yet. Due to backtracking, many states may be in use at any time during the matching process.
- A *MatchResult* is either a State or the special token **failure** that indicates that the match failed.
- A *Continuation* procedure is an internal closure (i.e. an internal procedure with some arguments already bound to values) that takes one State argument and returns a MatchResult result. If an internal closure references variables bound in the function that creates the closure, the closure uses the values that these variables had at the time the closure was created. The continuation attempts to match the remaining portion (specified by the closure's already-bound arguments) of the pattern against the input string, starting at the intermediate state given by its State argument. If the match succeeds, the continuation returns the final State that it reached; if the match fails, the continuation returns **failure**.
- A *Matcher* procedure is an internal closure that takes two arguments -- a State and a Continuation -- and returns a MatchResult result. The matcher attempts to match a middle subpattern (specified by the closure's already-bound arguments) of the pattern against the input string, starting at the intermediate state given by its State argument. The Continuation argument should be a closure that matches the rest of the pattern. After matching the subpattern of a pattern to obtain a new State, the matcher then calls Continuation on that state to test if the rest of the pattern can match as well. If it can, the matcher returns the state returned by the continuation; if not, the matcher may try different choices at its choice points, repeatedly calling Continuation until it either succeeds or all possibilities have been exhausted.
- An *AssertionTester* procedure is an internal closure that takes a State argument and returns a boolean result. The assertion tester tests a specific condition (specified by the closure's already-bound arguments) against the current place in the input string and returns **true** if the condition matched or **false** if not.
- An *EscapeValue* is either a character or an integer. An EscapeValue is used to denote the interpretation of a *DecimalEscape* escape sequence: a character *ch* means that the escape sequence is interpreted as the character *ch*, while an integer *n* means that the escape sequence is interpreted as a backreference to the *n*th set of capturing parentheses.

15.10.2.2 Pattern

The production *Pattern* :: *Disjunction* evaluates as follows:

1. Evaluate *Disjunction* to obtain a Matcher *m*.
2. Return an internal closure that takes two arguments, a string *str* and an integer *index*, and performs the following:
 1. Let *Input* be the given string *str*. This variable will be used throughout the algorithms in 15.10.2.
 2. Let *InputLength* be the length of *Input*. This variable will be used throughout the algorithms in 15.10.2.
 3. Let *c* be a Continuation that always returns its State argument as a successful MatchResult.
 4. Let *cap* be an internal array of *NcapturingParens* **undefined** values, indexed 1 through *NcapturingParens*.
 5. Let *x* be the State (*index*, *cap*).
 6. Call *m*(*x*, *c*) and return its result.

NOTE

A Pattern evaluates ("compiles") to an internal procedure value. `RegExp.prototype.exec` can then apply this procedure to a string and an offset within the string to determine whether the pattern would match starting at exactly that offset within the string, and, if it does match, what the values of the capturing parentheses would be. The algorithms in 15.10.2 are designed so that compiling a pattern may throw a **SyntaxError** exception; on the other hand, once the pattern is successfully compiled, applying its result internal procedure to find a match in a string cannot throw an exception (except for any host-defined exceptions that can occur anywhere such as out-of-memory).

15.10.2.3 Disjunction

The production *Disjunction* :: *Alternative* evaluates by evaluating *Alternative* to obtain a *Matcher* and returning that *Matcher*.

The production *Disjunction* :: *Alternative* | *Disjunction* evaluates as follows:

1. Evaluate *Alternative* to obtain a *Matcher* *m1*.
2. Evaluate *Disjunction* to obtain a *Matcher* *m2*.
3. Return an internal *Matcher* closure that takes two arguments, a *State* *x* and a *Continuation* *c*, and performs the following:
 1. Call *m1(x, c)* and let *r* be its result.
 2. If *r* isn't **failure**, return *r*.
 3. Call *m2(x, c)* and return its result.

NOTE

The `|` regular expression operator separates two alternatives. The pattern first tries to match the left *Alternative* (followed by the sequel of the regular expression); if it fails, it tries to match the right *Disjunction* (followed by the sequel of the regular expression). If the left *Alternative*, the right *Disjunction*, and the sequel all have choice points, all choices in the sequel are tried before moving on to the next choice in the left *Alternative*. If choices in the left *Alternative* are exhausted, the right *Disjunction* is tried instead of the left *Alternative*. Any capturing parentheses inside a portion of the pattern skipped by `|` produce **undefined** values instead of strings. Thus, for example,

```
/a|ab/.exec("abc")
```

returns the result `"a"` and not `"ab"`. Moreover,

```
/((a)|(ab))((c)|(bc))/.exec("abc")
```

returns the array

```
["abc", "a", "a", undefined, "bc", undefined, "bc"]
```

and not

```
["abc", "ab", undefined, "ab", "c", "c", undefined]
```

15.10.2.4 Alternative

The production *Alternative* :: `[empty]` evaluates by returning a *Matcher* that takes two arguments, a *State* *x* and a *Continuation* *c*, and returns the result of calling *c(x)*.

The production *Alternative* :: *Alternative Term* evaluates as follows:

1. Evaluate *Alternative* to obtain a *Matcher* *m1*.
2. Evaluate *Term* to obtain a *Matcher* *m2*.
3. Return an internal *Matcher* closure that takes two arguments, a *State* *x* and a *Continuation* *c*, and performs the following:
 1. Create a *Continuation* *d* that takes a *State* argument *y* and returns the result of calling *m2(y, c)*.
 2. Call *m1(x, d)* and return its result.

NOTE

Consecutive Terms try to simultaneously match consecutive portions of the input string. If the left *Alternative*, the right *Term*, and the sequel of the regular expression all have choice points, all

choices in the sequel are tried before moving on to the next choice in the right Term, and all choices in the right Term are tried before moving on to the next choice in the left Alternative.

15.10.2.5 Term

The production *Term* :: *Assertion* evaluates by returning an internal Matcher closure that takes two arguments, a State *x* and a Continuation *c*, and performs the following:

1. Evaluate *Assertion* to obtain an AssertionTester *t*.
2. Call *t(x)* and let *r* be the resulting boolean value.
3. If *r* is **false**, return **failure**.
4. Call *c(x)* and return its result.

The production *Term* :: *Atom* evaluates by evaluating *Atom* to obtain a Matcher and returning that Matcher.

The production *Term* :: *Atom Quantifier* evaluates as follows:

1. Evaluate *Atom* to obtain a Matcher *m*.
2. Evaluate *Quantifier* to obtain the three results: an integer *min*, an integer (or ∞) *max*, and boolean *greedy*.
3. If *max* is finite and less than *min*, then throw a **SyntaxError** exception.
4. Let *parenIndex* be the number of left capturing parentheses in the entire regular expression that occur to the left of this production expansion's *Term*. This is the total number of times the *Atom* :: (*Disjunction*) production is expanded prior to this production's *Term* plus the total number of *Atom* :: (*Disjunction*) productions enclosing this *Term*.
5. Let *parenCount* be the number of left capturing parentheses in the expansion of this production's *Atom*. This is the total number of *Atom* :: (*Disjunction*) productions enclosed by this production's *Atom*.
6. Return an internal Matcher closure that takes two arguments, a State *x* and a Continuation *c*, and performs the following:
 1. Call RepeatMatcher(*m*, *min*, *max*, *greedy*, *x*, *c*, *parenIndex*, *parenCount*) and return its result.

The abstract operation *RepeatMatcher* takes eight parameters, a Matcher *m*, an integer *min*, an integer (or ∞) *max*, a boolean *greedy*, a State *x*, a Continuation *c*, an integer *parenIndex*, and an integer *parenCount*, and performs the following:

1. If *max* is zero, then call *c(x)* and return its result.
2. Create an internal Continuation closure *d* that takes one State argument *y* and performs the following:
 1. If *min* is zero and *y*'s *endIndex* is equal to *x*'s *endIndex*, then return **failure**.
 2. If *min* is zero then let *min2* be zero; otherwise let *min2* be *min*-1.
 3. If *max* is ∞ , then let *max2* be ∞ ; otherwise let *max2* be *max*-1.
 4. Call RepeatMatcher(*m*, *min2*, *max2*, *greedy*, *y*, *c*, *parenIndex*, *parenCount*) and return its result.
3. Let *cap* be a fresh copy of *x*'s *captures* internal array.
4. For every integer *k* that satisfies *parenIndex* < *k* and *k* ≤ *parenIndex*+*parenCount*, set *cap*[*k*] to **undefined**.
5. Let *e* be *x*'s *endIndex*.
6. Let *xr* be the State (*e*, *cap*).
7. If *min* is not zero, then call *m(xr, d)* and return its result.
8. If *greedy* is **false**, then
 - a. Call *c(x)* and let *z* be its result.
 - b. If *z* is not **failure**, return *z*.
 - c. Call *m(xr, d)* and return its result.
9. Call *m(xr, d)* and let *z* be its result.
10. If *z* is not **failure**, return *z*.
11. Call *c(x)* and return its result.

NOTE

An Atom followed by a Quantifier is repeated the number of times specified by the Quantifier. A quantifier can be non-greedy, in which case the Atom pattern is repeated as few times as possible while still matching the sequel, or it can be greedy, in which case the Atom pattern is repeated as many times as possible while still matching the sequel. The Atom pattern is repeated rather than the input string that it matches, so different repetitions of the Atom can match different input substrings.

If the Atom and the sequel of the regular expression all have choice points, the Atom is first matched as many (or as few, if non-greedy) times as possible. All choices in the sequel are tried before moving on to the next choice in the last repetition of Atom. All choices in the last (n^{th}) repetition of Atom are tried before moving on to the next choice in the next-to-last ($(n-1)^{\text{st}}$) repetition of Atom; at which point it may turn out that more or fewer repetitions of Atom are now possible; these are exhausted (again, starting with either as few or as many as possible) before moving on to the next choice in the $(n-1)^{\text{st}}$ repetition of Atom and so on.

Compare

```
/a[a-z]{2,4}/.exec("abcdefghi")
```

which returns "abcde" with

```
/a[a-z]{2,4}?/.exec("abcdefghi")
```

which returns "abc".

Consider also

```
/(aa|aabaac|ba|b|c)*/.exec("aabaac")
```

which, by the choice point ordering above, returns the array

```
["aaba", "ba"]
```

and not any of:

```
["aabaac", "aabaac"]
```

```
["aabaac", "c"]
```

The above ordering of choice points can be used to write a regular expression that calculates the greatest common divisor of two numbers (represented in unary notation). The following example calculates the gcd of 10 and 15:

```
"aaaaaaaaaa,aaaaaaaaaaaaa".replace(/^(a+)\1*,\1+$/, "$1")
```

which returns the gcd in unary notation "aaaaa".

Step 4 of the RepeatMatcher clears Atom's captures each time Atom is repeated. We can see its behaviour in the regular expression

```
/(z)((a+)?(b+)?(c))*/.exec("zaacbbbcac")
```

which returns the array

```
["zaacbbbcac", "z", "ac", "a", undefined, "c"]
```

and not

```
["zaacbbbcac", "z", "ac", "a", "bbb", "c"]
```

because each iteration of the outermost * clears all captured strings contained in the quantified Atom, which in this case includes capture strings numbered 2, 3, and 4.

Step 1 of the RepeatMatcher's closure d states that, once the minimum number of repetitions has been satisfied, any more expansions of Atom that match the empty string are not considered for further repetitions. This prevents the regular expression engine from falling into an infinite loop on patterns such as:

```
/(a*)*/.exec("b")
```

or the slightly more complicated:

```
/(a*)b\1+/.exec("baaaac")
```

which returns the array

```
["b", ""]
```

15.10.2.6 Assertion

The production *Assertion* :: ^ evaluates by returning an internal *AssertionTester* closure that takes a *State* argument *x* and performs the following:

1. Let *e* be *x*'s *endIndex*.
2. If *e* is zero, return **true**.
3. If *Multiline* is **false**, return **false**.
4. If the character *Input*[*e*-1] is one of *LineTerminator*, return **true**.
5. Return **false**.

The production *Assertion* :: \$ evaluates by returning an internal *AssertionTester* closure that takes a *State* argument *x* and performs the following:

1. Let *e* be *x*'s *endIndex*.
2. If *e* is equal to *InputLength*, return **true**.
3. If *multiline* is **false**, return **false**.
4. If the character *Input*[*e*] is one of *LineTerminator*, return **true**.
5. Return **false**.

The production *Assertion* :: \ b evaluates by returning an internal *AssertionTester* closure that takes a *State* argument *x* and performs the following:

1. Let *e* be *x*'s *endIndex*.
2. Call *IsWordChar*(*e*-1) and let *a* be the boolean result.
3. Call *IsWordChar*(*e*) and let *b* be the boolean result.
4. If *a* is **true** and *b* is **false**, return **true**.
5. If *a* is **false** and *b* is **true**, return **true**.
6. Return **false**.

The production *Assertion* :: \ B evaluates by returning an internal *AssertionTester* closure that takes a *State* argument *x* and performs the following:

1. Let *e* be *x*'s *endIndex*.
2. Call *IsWordChar*(*e*-1) and let *a* be the boolean result.
3. Call *IsWordChar*(*e*) and let *b* be the boolean result.
4. If *a* is **true** and *b* is **false**, return **false**.
5. If *a* is **false** and *b* is **true**, return **false**.
6. Return **true**.

The production *Assertion* :: (? = *Disjunction*) evaluates as follows:

1. Evaluate *Disjunction* to obtain a *Matcher* *m*.
2. Return an internal *Matcher* closure that takes two arguments, a *State* *x* and a *Continuation* *c*, and performs the following steps:
 1. Let *d* be a *Continuation* that always returns its *State* argument as a successful *MatchResult*.
 2. Call *m*(*x*, *d*) and let *r* be its result.
 3. If *r* is **failure**, return **failure**.
 4. Let *y* be *r*'s *State*.
 5. Let *cap* be *y*'s *captures* internal array.
 6. Let *xe* be *x*'s *endIndex*.
 7. Let *z* be the *State* (*xe*, *cap*).
 8. Call *c*(*z*) and return its result.

The production *Assertion* :: (? ! *Disjunction*) evaluates as follows:

1. Evaluate *Disjunction* to obtain a Matcher *m*.
2. Return an internal Matcher closure that takes two arguments, a State *x* and a Continuation *c*, and performs the following steps:
 1. Let *d* be a Continuation that always returns its State argument as a successful MatchResult.
 2. Call *m(x, d)* and let *r* be its result.
 3. If *r* isn't **failure**, return **failure**.
 4. Call *c(x)* and return its result.

The abstract operation *IsWordChar* takes an integer parameter *e* and performs the following:

1. If *e* == -1 or *e* == *InputLength*, return **false**.
2. Let *c* be the character *Input[e]*.
3. If *c* is one of the sixty-three characters in the table below, return **true**.

| | | | | | | | | | | | | | | | | | | | | | | | | | |
|---|---|---|---|---|---|---|---|---|---|---|---|---|---|---|---|---|---|---|---|---|---|---|---|---|---|
| A | b | c | d | e | f | g | h | i | j | k | l | m | n | o | p | q | r | s | t | u | v | w | x | y | z |
| A | B | C | D | E | F | G | H | I | J | K | L | M | N | O | P | Q | R | S | T | U | V | W | X | Y | Z |
| 0 | 1 | 2 | 3 | 4 | 5 | 6 | 7 | 8 | 9 | _ | | | | | | | | | | | | | | | |

4. Return **false**.

15.10.2.7 Quantifier

The production *Quantifier* :: *QuantifierPrefix* evaluates as follows:

1. Evaluate *QuantifierPrefix* to obtain the two results: an integer *min* and an integer (or ∞) *max*.
2. Return the three results *min*, *max*, and **true**.

The production *Quantifier* :: *QuantifierPrefix* ? evaluates as follows:

1. Evaluate *QuantifierPrefix* to obtain the two results: an integer *min* and an integer (or ∞) *max*.
2. Return the three results *min*, *max*, and **false**.

The production *QuantifierPrefix* :: * evaluates by returning the two results 0 and ∞ .

The production *QuantifierPrefix* :: + evaluates by returning the two results 1 and ∞ .

The production *QuantifierPrefix* :: ? evaluates by returning the two results 0 and 1.

The production *QuantifierPrefix* :: { *DecimalDigits* } evaluates as follows:

1. Let *i* be the MV of *DecimalDigits* (see 7.8.3).
2. Return the two results *i* and *i*.

The production *QuantifierPrefix* :: { *DecimalDigits* , } evaluates as follows:

1. Let *i* be the MV of *DecimalDigits*.
2. Return the two results *i* and ∞ .

The production *QuantifierPrefix* :: { *DecimalDigits* , *DecimalDigits* } evaluates as follows:

1. Let *i* be the MV of the first *DecimalDigits*.
2. Let *j* be the MV of the second *DecimalDigits*.
3. Return the two results *i* and *j*.

15.10.2.8 Atom

The production *Atom* :: *PatternCharacter* evaluates as follows:

1. Let *ch* be the character represented by *PatternCharacter*.
2. Let *A* be a one-element CharSet containing the character *ch*.
3. Call *CharacterSetMatcher(A, false)* and return its Matcher result.

The production *Atom* :: *.* evaluates as follows:

1. Let *A* be the set of all characters except *LineTerminator*.
2. Call *CharacterSetMatcher(A, false)* and return its *Matcher* result.

The production *Atom* :: *\ AtomEscape* evaluates by evaluating *AtomEscape* to obtain a *Matcher* and returning that *Matcher*.

The production *Atom* :: *CharacterClass* evaluates as follows:

1. Evaluate *CharacterClass* to obtain a *CharSet A* and a boolean *invert*.
2. Call *CharacterSetMatcher(A, invert)* and return its *Matcher* result.

The production *Atom* :: *(Disjunction)* evaluates as follows:

1. Evaluate *Disjunction* to obtain a *Matcher m*.
2. Let *parenIndex* be the number of left capturing parentheses in the entire regular expression that occur to the left of this production expansion's initial left parenthesis. This is the total number of times the *Atom* :: *(Disjunction)* production is expanded prior to this production's *Atom* plus the total number of *Atom* :: *(Disjunction)* productions enclosing this *Atom*.
3. Return an internal *Matcher* closure that takes two arguments, a *State x* and a *Continuation c*, and performs the following steps:
 1. Create an internal *Continuation* closure *d* that takes one *State* argument *y* and performs the following steps:
 1. Let *cap* be a fresh copy of *y*'s *captures* internal array.
 2. Let *xe* be *x*'s *endIndex*.
 3. Let *ye* be *y*'s *endIndex*.
 4. Let *s* be a fresh string whose characters are the characters of *Input* at positions *xe* (inclusive) through *ye* (exclusive).
 5. Set *cap[parenIndex+1]* to *s*.
 6. Let *z* be the *State (ye, cap)*.
 7. Call *c(z)* and return its result.
 2. Call *m(x, d)* and return its result.

The production *Atom* :: *(? : Disjunction)* evaluates by evaluating *Disjunction* to obtain a *Matcher* and returning that *Matcher*.

The abstract operation *CharacterSetMatcher* takes two arguments, a *CharSet A* and a boolean flag *invert*, and performs the following:

1. Return an internal *Matcher* closure that takes two arguments, a *State x* and a *Continuation c*, and performs the following steps:
 1. Let *e* be *x*'s *endIndex*.
 2. If *e* == *InputLength*, return **failure**.
 3. Let *c* be the character *Input[e]*.
 4. Let *cc* be the result of *Canonicalize(c)*.
 5. If *invert* is **false**, then
 - a. If there does not exist a member *a* of set *A* such that *Canonicalize(a)* == *cc*, return **failure**.
 6. Else *invert* is **true**,
 - a. If there exists a member *a* of set *A* such that *Canonicalize(a)* == *cc*, return **failure**.
 7. Let *cap* be *x*'s *captures* internal array.
 8. Let *y* be the *State (e+1, cap)*.
 9. Call *c(y)* and return its result.

The abstract operation *Canonicalize* takes a character parameter *ch* and performs the following steps:

1. If *IgnoreCase* is **false**, return *ch*.
2. Let *u* be *ch* converted to upper case as if by calling the standard built-in method **String.prototype.toUpperCase** on the one-character string *ch*.

3. If *u* does not consist of a single character, return *ch*.
4. Let *cu* be *u*'s character.
5. If *ch*'s code unit value is greater than or equal to decimal 128 and *cu*'s code unit value is less than decimal 128, then return *ch*.
6. Return *cu*.

NOTE

Parentheses of the form (Disjunction) serve both to group the components of the Disjunction pattern together and to save the result of the match. The result can be used either in a backreference (\ followed by a nonzero decimal number), referenced in a replace string, or returned as part of an array from the regular expression matching internal procedure. To inhibit the capturing behaviour of parentheses, use the form (?: Disjunction) instead.

The form (?= Disjunction) specifies a zero-width positive lookahead. In order for it to succeed, the pattern inside Disjunction must match at the current position, but the current position is not advanced before matching the sequel. If Disjunction can match at the current position in several ways, only the first one is tried. Unlike other regular expression operators, there is no backtracking into a (?= form (this unusual behaviour is inherited from Perl). This only matters when the Disjunction contains capturing parentheses and the sequel of the pattern contains backreferences to those captures.

For example,

```
/ (?= (a+)) / .exec ("baaabac")
```

matches the empty string immediately after the first **b** and therefore returns the array:

```
["", "aaa"]
```

To illustrate the lack of backtracking into the lookahead, consider:

```
/ (?= (a+)) a*b\1 / .exec ("baaabac")
```

This expression returns

```
["aba", "a"]
```

and not:

```
["aaaba", "a"]
```

The form (?! Disjunction) specifies a zero-width negative lookahead. In order for it to succeed, the pattern inside Disjunction must fail to match at the current position. The current position is not advanced before matching the sequel. Disjunction can contain capturing parentheses, but backreferences to them only make sense from within Disjunction itself. Backreferences to these capturing parentheses from elsewhere in the pattern always return **undefined** because the negative lookahead must fail for the pattern to succeed. For example,

```
/ (.*) a (?! (a+) b\2c) \2 (.*) / .exec ("baaabaac")
```

looks for an **a** not immediately followed by some positive number *n* of **a**'s, a **b**, another *n* **a**'s (specified by the first \2) and a **c**. The second \2 is outside the negative lookahead, so it matches against **undefined** and therefore always succeeds. The whole expression returns the array:

```
["baaabaac", "ba", undefined, "abaac"]
```

In case-insignificant matches all characters are implicitly converted to upper case immediately before they are compared. However, if converting a character to upper case would expand that character into more than one character (such as converting "ß" (\u00DF) into "SS"), then the character is left as-is instead. The character is also left as-is if it is not an ASCII character but converting it to upper case would make it into an ASCII character. This prevents Unicode characters such as \u0131 and \u017F from matching regular expressions such as /[a-z]/i, which are only intended to match ASCII letters. Furthermore, if these conversions were allowed, then /^[^\W]/i would match each of **a**, **b**, ..., **h**, but not **i** or **s**.

15.10.2.9 AtomEscape

The production *AtomEscape* :: *DecimalEscape* evaluates as follows:

1. Evaluate *DecimalEscape* to obtain an *EscapeValue* *E*.
2. If *E* is a character, then
 - a. Let *ch* be *E*'s character.
 - b. Let *A* be a one-element *CharSet* containing the character *ch*.
 - c. Call *CharacterSetMatcher*(*A*, **false**) and return its *Matcher* result.
3. *E* must be an integer. Let *n* be that integer.
4. If *n*=0 or *n*>*NCapturingParens* then throw a **SyntaxError** exception.
5. Return an internal *Matcher* closure that takes two arguments, a *State* *x* and a *Continuation* *c*, and performs the following:
 1. Let *cap* be *x*'s *captures* internal array.
 2. Let *s* be *cap*[*n*].
 3. If *s* is **undefined**, then call *c*(*x*) and return its result.
 4. Let *e* be *x*'s *endIndex*.
 5. Let *len* be *s*'s length.
 6. Let *f* be *e*+*len*.
 7. If *f*>*InputLength*, return **failure**.
 8. If there exists an integer *i* between 0 (inclusive) and *len* (exclusive) such that *Canonicalize*(*s*[*i*]) is not the same character as *Canonicalize*(*Input* [*e*+*i*]), then return **failure**.
 9. Let *y* be the *State* (*f*, *cap*).
 10. Call *c*(*y*) and return its result.

The production *AtomEscape* :: *CharacterEscape* evaluates as follows:

1. Evaluate *CharacterEscape* to obtain a character *ch*.
2. Let *A* be a one-element *CharSet* containing the character *ch*.
3. Call *CharacterSetMatcher*(*A*, **false**) and return its *Matcher* result.

The production *AtomEscape* :: *CharacterClassEscape* evaluates as follows:

1. Evaluate *CharacterClassEscape* to obtain a *CharSet* *A*.
2. Call *CharacterSetMatcher*(*A*, **false**) and return its *Matcher* result.

NOTE

An escape sequence of the form \backslash followed by a nonzero decimal number *n* matches the result of the *n*th set of capturing parentheses (see 15.10.2.11). It is an error if the regular expression has fewer than *n* capturing parentheses. If the regular expression has *n* or more capturing parentheses but the *n*th one is **undefined** because it hasn't captured anything, then the backreference always succeeds.

15.10.2.10 CharacterEscape

The production *CharacterEscape* :: *ControlEscape* evaluates by returning the character according to the table below:

| <i>ControlEscape</i> | <i>Code Unit</i> | <i>Name</i> | <i>Symbol</i> |
|----------------------|--------------------|----------------------|---------------|
| t | \backslash u0009 | horizontal tab | <HT> |
| n | \backslash u000A | line feed (new line) | <LF> |
| v | \backslash u000B | vertical tab | <VT> |
| f | \backslash u000C | form feed | <FF> |
| r | \backslash u000D | carriage return | <CR> |

The production *CharacterEscape* :: **c** *ControlLetter* evaluates as follows:

1. Let *ch* be the character represented by *ControlLetter*.
2. Let *i* be *ch*'s code unit value.
3. Let *j* be the remainder of dividing *i* by 32.

4. Return the code unit numbered *j*.

The production *CharacterEscape* :: *HexEscapeSequence* evaluates by evaluating the CV of the *HexEscapeSequence* (see 7.8.4) and returning its character result.

The production *CharacterEscape* :: *UnicodeEscapeSequence* evaluates by evaluating the CV of the *UnicodeEscapeSequence* (see 7.8.4) and returning its character result.

The production *CharacterEscape* :: *IdentityEscape* evaluates by returning the character represented by *IdentityEscape*.

15.10.2.11 DecimalEscape

The production *DecimalEscape* :: *DecimalIntegerLiteral* [lookahead ∉ *DecimalDigit*] evaluates as follows.

1. Let *i* be the MV of *DecimalIntegerLiteral*.
2. If *i* is zero, return the EscapeValue consisting of a <NUL> character (Unicode value 0000).
3. Return the EscapeValue consisting of the integer *i*.

The definition of “the MV of *DecimalIntegerLiteral*” is in 7.8.3.

NOTE

If \backslash is followed by a decimal number *n* whose first digit is not 0, then the escape sequence is considered to be a backreference. It is an error if *n* is greater than the total number of left capturing parentheses in the entire regular expression. $\backslash 0$ represents the NUL character and cannot be followed by a decimal digit.

15.10.2.12 CharacterClassEscape

The production *CharacterClassEscape* :: **d** evaluates by returning the ten-element set of characters containing the characters 0 through 9 inclusive.

The production *CharacterClassEscape* :: **D** evaluates by returning the set of all characters not included in the set returned by *CharacterClassEscape* :: **d**.

The production *CharacterClassEscape* :: **s** evaluates by returning the set of characters containing the characters that are on the right-hand side of the *WhiteSpace* (7.2) or *LineTerminator* (7.3) productions.

The production *CharacterClassEscape* :: **S** evaluates by returning the set of all characters not included in the set returned by *CharacterClassEscape* :: **s**.

The production *CharacterClassEscape* :: **w** evaluates by returning the set of characters containing the sixty-three characters:

```

a b c d e f g h i j k l m n o p q r s t u v w x y z
A B C D E F G H I J K L M N O P Q R S T U V W X Y Z
0 1 2 3 4 5 6 7 8 9 _

```

The production *CharacterClassEscape* :: **W** evaluates by returning the set of all characters not included in the set returned by *CharacterClassEscape* :: **w**.

15.10.2.13 CharacterClass

The production *CharacterClass* :: [[lookahead ∉ {^}] *ClassRanges*] evaluates by evaluating *ClassRanges* to obtain a CharSet and returning that CharSet and the boolean **false**.

The production *CharacterClass* :: [^ *ClassRanges*] evaluates by evaluating *ClassRanges* to obtain a CharSet and returning that CharSet and the boolean **true**.

15.10.2.14 ClassRanges

The production *ClassRanges* :: [empty] evaluates by returning the empty CharSet.

The production *ClassRanges* :: *NonemptyClassRanges* evaluates by evaluating *NonemptyClassRanges* to obtain a CharSet and returning that CharSet.

15.10.2.15 NonemptyClassRanges

The production *NonemptyClassRanges* :: *ClassAtom* evaluates by evaluating *ClassAtom* to obtain a CharSet and returning that CharSet.

The production *NonemptyClassRanges* :: *ClassAtom NonemptyClassRangesNoDash* evaluates as follows:

1. Evaluate *ClassAtom* to obtain a CharSet *A*.
2. Evaluate *NonemptyClassRangesNoDash* to obtain a CharSet *B*.
3. Return the union of CharSets *A* and *B*.

The production *NonemptyClassRanges* :: *ClassAtom - ClassAtom ClassRanges* evaluates as follows:

1. Evaluate the first *ClassAtom* to obtain a CharSet *A*.
2. Evaluate the second *ClassAtom* to obtain a CharSet *B*.
3. Evaluate *ClassRanges* to obtain a CharSet *C*.
4. Call *CharacterRange(A, B)* and let *D* be the resulting CharSet.
5. Return the union of CharSets *D* and *C*.

The abstract operation *CharacterRange* takes two CharSet parameters *A* and *B* and performs the following:

1. If *A* does not contain exactly one character or *B* does not contain exactly one character then throw a **SyntaxError** exception.
2. Let *a* be the one character in CharSet *A*.
3. Let *b* be the one character in CharSet *B*.
4. Let *i* be the code unit value of character *a*.
5. Let *j* be the code unit value of character *b*.
6. If $i > j$ then throw a **SyntaxError** exception.
7. Return the set containing all characters numbered *i* through *j*, inclusive.

15.10.2.16 NonemptyClassRangesNoDash

The production *NonemptyClassRangesNoDash* :: *ClassAtom* evaluates by evaluating *ClassAtom* to obtain a CharSet and returning that CharSet.

The production *NonemptyClassRangesNoDash* :: *ClassAtomNoDash NonemptyClassRangesNoDash* evaluates as follows:

1. Evaluate *ClassAtomNoDash* to obtain a CharSet *A*.
2. Evaluate *NonemptyClassRangesNoDash* to obtain a CharSet *B*.
3. Return the union of CharSets *A* and *B*.

The production *NonemptyClassRangesNoDash* :: *ClassAtomNoDash - ClassAtom ClassRanges* evaluates as follows:

1. Evaluate *ClassAtomNoDash* to obtain a CharSet *A*.
2. Evaluate *ClassAtom* to obtain a CharSet *B*.
3. Evaluate *ClassRanges* to obtain a CharSet *C*.
4. Call *CharacterRange(A, B)* and let *D* be the resulting CharSet.
5. Return the union of CharSets *D* and *C*.

NOTE

ClassRanges can expand into single *ClassAtoms* and/or ranges of two *ClassAtoms* separated by dashes. In the latter case the *ClassRanges* includes all characters between the first *ClassAtom* and the second *ClassAtom*, inclusive; an error occurs if either *ClassAtom* does not represent a single character (for example, if one is `\w`) or if the first *ClassAtom*'s code unit value is greater than the second *ClassAtom*'s code unit value.

Even if the pattern ignores case, the case of the two ends of a range is significant in determining which characters belong to the range. Thus, for example, the pattern `/[E-F]/i` matches only the

letters **E**, **F**, **e**, and **f**, while the pattern `/[E-f]/i` matches all upper and lower-case ASCII letters as well as the symbols `[, \,], ^, _` and ```.

A - character can be treated literally or it can denote a range. It is treated literally if it is the first or last character of `ClassRanges`, the beginning or end limit of a range specification, or immediately follows a range specification.

15.10.2.17 **ClassAtom**

The production `ClassAtom :: -` evaluates by returning the `CharSet` containing the one character `-`.

The production `ClassAtom :: ClassAtomNoDash` evaluates by evaluating `ClassAtomNoDash` to obtain a `CharSet` and returning that `CharSet`.

15.10.2.18 **ClassAtomNoDash**

The production `ClassAtomNoDash :: SourceCharacter` but not one of `\] -` evaluates by returning a one-element `CharSet` containing the character represented by `SourceCharacter`.

The production `ClassAtomNoDash :: \ ClassEscape` evaluates by evaluating `ClassEscape` to obtain a `CharSet` and returning that `CharSet`.

15.10.2.19 **ClassEscape**

The production `ClassEscape :: DecimalEscape` evaluates as follows:

1. Evaluate `DecimalEscape` to obtain an `EscapeValue E`.
2. If *E* is not a character then throw a **SyntaxError** exception.
3. Let *ch* be *E*'s character.
4. Return the one-element `CharSet` containing the character *ch*.

The production `ClassEscape :: b` evaluates by returning the `CharSet` containing the one character `<BS>` (Unicode value 0008).

The production `ClassEscape :: CharacterEscape` evaluates by evaluating `CharacterEscape` to obtain a character and returning a one-element `CharSet` containing that character.

The production `ClassEscape :: CharacterClassEscape` evaluates by evaluating `CharacterClassEscape` to obtain a `CharSet` and returning that `CharSet`.

NOTE

A ClassAtom can use any of the escape sequences that are allowed in the rest of the regular expression except for `\b`, `\B`, and backreferences. Inside a CharacterClass, `\b` means the backspace character, while `\B` and backreferences raise errors. Using a backreference inside a ClassAtom causes an error.

15.10.3 The **RegExp** Constructor Called as a Function

15.10.3.1 **RegExp(pattern, flags)**

If *pattern* is an object *R* whose `[[Class]]` internal property is `"RegExp"` and *flags* is **undefined**, then return *R* unchanged. Otherwise call the standard built-in **RegExp** constructor (15.10.4.1) as if by the expression `new RegExp(pattern, flags)` and return the object constructed by that constructor.

15.10.4 The **RegExp** Constructor

When **RegExp** is called as part of a **new** expression, it is a constructor: it initialises the newly created object.

15.10.4.1 **new RegExp(pattern, flags)**

If *pattern* is an object *R* whose `[[Class]]` internal property is `"RegExp"` and *flags* is **undefined**, then let *P* be the *pattern* used to construct *R* and let *F* be the flags used to construct *R*. If *pattern* is an object *R* whose `[[Class]]` internal property is `"RegExp"` and *flags* is not **undefined**, then throw a **TypeError** exception. Otherwise, let *P* be the empty string if *pattern* is **undefined** and `ToString(pattern)` otherwise, and let *F* be the empty string if *flags* is **undefined** and `ToString(flags)` otherwise.

If the characters of *P* do not have the syntactic form *Pattern*, then throw a **SyntaxError** exception. Otherwise let the newly constructed object have a `[[Match]]` internal property obtained by evaluating ("compiling") the characters of *P* as a *Pattern* as described in section 15.10.2.

If *F* contains any character other than "g", "i", or "m", or if it contains the same character more than once, then throw a **SyntaxError** exception.

If a **SyntaxError** exception is not thrown, then:

Let *S* be a string in the form of a *Pattern* equivalent to *P*, in which certain characters are escaped as described below. *S* may or may not be identical to *P* or *pattern*; however, the internal procedure that would result from evaluating *S* as a *Pattern* must behave identically to the internal procedure given by the constructed object's `[[Match]]` internal property.

The characters */* or *backslash* \ occurring in the pattern shall be escaped in *S* as necessary to ensure that the string value formed by concatenating the strings */*, *S*, */*, and *F* can be parsed (in an appropriate lexical context) as a *RegularExpressionLiteral* that behaves identically to the constructed regular expression. For example, if *P* is */*, then *S* could be `\/` or `\u002F`, among other possibilities, but not `/`, because `///` followed by *F* would be parsed as a *SingleLineComment* rather than a *RegularExpressionLiteral*. If *P* is the empty string, this specification can be met by letting *S* be `(?:)`.

The following properties of the newly constructed object are data properties with the attributes that are specified in 15.10.7. The `[[Value]]` of each property is set as follows:

The **source** property of the newly constructed object is set to *S*.

The **global** property of the newly constructed object is set to a Boolean value that is **true** if *F* contains the character "g" and **false** otherwise.

The **ignoreCase** property of the newly constructed object is set to a Boolean value that is **true** if *F* contains the character "i" and **false** otherwise.

The **multiline** property of the newly constructed object is set to a Boolean value that is **true** if *F* contains the character "m" and **false** otherwise.

The **lastIndex** property of the newly constructed object is set to 0.

The `[[Prototype]]` internal property of the newly constructed object is set to the standard built-in `RegExp` prototype object as specified in 15.10.6.

The `[[Class]]` internal property of the newly constructed object is set to `"RegExp"`.

NOTE

If pattern is a StringLiteral, the usual escape sequence substitutions are performed before the string is processed by RegExp. If pattern must contain an escape sequence to be recognised by RegExp, any backslash \ characters must be escaped within the StringLiteral to prevent them being removed when the contents of the StringLiteral are formed.

15.10.5 Properties of the RegExp Constructor

The value of the `[[Prototype]]` internal property of the `RegExp` constructor is the standard built-in `Function` prototype object (15.3.4).

Besides the internal properties and the **length** property (whose value is 2), the `RegExp` constructor has the following properties:

15.10.5.1 RegExp.prototype

The initial value of `RegExp.prototype` is the `RegExp` prototype object (15.10.6).

This property shall have the attributes { `[[Writable]]`: **false**, `[[Enumerable]]`: **false**, `[[Configurable]]`: **false** }.

15.10.6 Properties of the RegExp Prototype Object

The value of the `[[Prototype]]` internal property of the RegExp prototype object is the standard built-in Object prototype object (15.2.4). The RegExp prototype object is itself a regular expression object; its `[[Class]]` is **"RegExp"**. The initial values of the RegExp prototype object's data properties (15.10.7) are set as if the object was created by the expression `new RegExp()` where **RegExp** is that standard built-in constructor with that name.

The RegExp prototype object does not have a `valueOf` property of its own; however, it inherits the `valueOf` property from the Object prototype object.

In the following descriptions of functions that are properties of the RegExp prototype object, the phrase "this RegExp object" refers to the object that is the **this** value for the invocation of the function; a **TypeError** exception is thrown if the **this** value is not an object or an object for which the value of the `[[Class]]` internal property is not **"RegExp"**.

15.10.6.1 RegExp.prototype.constructor

The initial value of `RegExp.prototype.constructor` is the standard built-in **RegExp** constructor.

15.10.6.2 RegExp.prototype.exec(string)

Performs a regular expression match of *string* against the regular expression and returns an Array object containing the results of the match, or **null** if the string did not match

The string `ToString(string)` is searched for an occurrence of the regular expression pattern as follows:

1. Let *R* be this RegExp object.
2. Let *S* be the value of `ToString(string)`.
3. Let *length* be the length of *S*.
4. Let *lastIndex* be the value of the `lastIndex` property.
5. Let *i* be the value of `ToInteger(lastIndex)`.
6. Let *global* be the result of calling the `[[Get]]` internal method of *R* with argument **"global"**.
7. If *global* is **false**, then let *i* = 0.
8. Let *matchSucceeded* be **false**.
9. Repeat, while *matchSucceeded* is **false**
 - a. If *i* < 0 or *i* > *length*, then
 - i. Call the `[[Put]]` internal method of *R* with arguments **"lastIndex"**, 0, and **true**.
 - ii. Return **null**.
 - b. Call the `[[Match]]` internal method of *R* with arguments *S* and *i*.
 - c. If `[[Match]]` returned **failure**, then
 - i. Let *i* = *i* + 1.
 - d. else
 - i. Let *r* be the State result of the call to `[[Match]]`.
 - ii. Set *matchSucceeded* to **true**.
 - e. Let *i* = *i* + 1.
10. Let *e* be *r*'s `endIndex` value.
11. If *global* is **true**, set `lastIndex` to *e*.
 - a. Call the `[[Put]]` internal method of *R* with arguments **"lastIndex"**, *e*, and **true**.
12. Let *n* be the length of *r*'s `captures` array. (This is the same value as 15.10.2.1's `NCapturingParens`.)
13. Let *A* be a new array created as if by the expression `new Array()` where **Array** is the standard built-in constructor with that name.
14. Let *matchIndex* be the position of the matched substring within the complete string *S*.
15. Call the `[[DefineOwnProperty]]` internal method of *A* with arguments **"index"**, Property Descriptor `{[[Value]]: matchIndex, [[Writable]]: true, [[Enumerable]]: true, [[Configurable]]: true}`, and **true**.
16. Call the `[[DefineOwnProperty]]` internal method of *A* with arguments **"input"**, Property Descriptor `{[[Value]]: S, [[Writable]]: true, [[Enumerable]]: true, [[Configurable]]: true}`, and **true**.

17. Call the `[[DefineOwnProperty]]` internal method of *A* with arguments "**length**", Property Descriptor `{[[Value]]: n + 1, [[Writable]]: true, [[Enumerable]]: true, [[Configurable]]: true}`, and **true**.
18. Let *matchedSubstr* be the matched substring (i.e. the portion of *S* between offset *i* inclusive and offset *e* exclusive).
19. Call the `[[DefineOwnProperty]]` internal method of *A* with arguments "**0**", Property Descriptor `{[[Value]]: matchedSubstr, [[Writable]]: true, [[Enumerable]]: true, [[Configurable]]: true}`, and **true**.
20. For each integer *i* such that $I > 0$ and $I \leq n$
 - a. Let *captureI* be *i*th element of *r*'s *captures* array.
 - b. Call the `[[DefineOwnProperty]]` internal method of *A* with arguments `ToString(i)`, Property Descriptor `{[[Value]]: captureI, [[Writable]]: true, [[Enumerable]]: true, [[Configurable]]: true}`, and **true**.
21. Return *A*.

15.10.6.3 `RegExp.prototype.test(string)`

The following steps are taken:

1. Let *match* be the result of evaluating the `RegExp.prototype.exec` (15.10.6.3) algorithm upon this `RegExp` object using *string* as the argument.
2. If *match* is not null, then return **true**; else return **false**.

15.10.6.4 `RegExp.prototype.toString()`

Return the string value formed by concatenating the strings `"/"`, the string value of the **source** property of this `RegExp` object, and `"/"`; plus **"g"** if the **global** property is **true**, **"i"** if the **ignoreCase** property is **true**, and **"m"** if the **multiline** property is **true**.

NOTE

The returned string has the form of a `RegularExpressionLiteral` that evaluates to another `RegExp` object with the same behaviour as this object.

15.10.7 Properties of `RegExp` Instances

`RegExp` instances inherit properties from the `RegExp` prototype object and their `[[Class]]` internal property value is `"RegExp"`. `RegExp` instances also have a `[[Match]]` property and a **length** property.

The value of the `[[Match]]` internal property is an implementation dependent representation of the *Pattern* of the `RegExp` object.

`RegExp` instances also have the following properties.

15.10.7.1 **source**

The value of the **source** property is string in the form of a *Pattern* representing the current regular expression. This property shall have the attributes `{ [[Writable]]: false, [[Enumerable]]: false, [[Configurable]]: false }`.

15.10.7.2 **global**

The value of the **global** property is a Boolean value indicating whether the flags contained the character `"g"`. This property shall have the attributes `{ [[Writable]]: false, [[Enumerable]]: false, [[Configurable]]: false }`.

15.10.7.3 **ignoreCase**

The value of the **ignoreCase** property is a Boolean value indicating whether the flags contained the character `"i"`. This property shall have the attributes `{ [[Writable]]: false, [[Enumerable]]: false, [[Configurable]]: false }`.

15.10.7.4 multiline

The value of the **multiline** property is a Boolean value indicating whether the flags contained the character "m". This property shall have the attributes { **[[Writable]]: false**, **[[Enumerable]]: false**, **[[Configurable]]: false** }.

15.10.7.5 lastIndex

The value of the **lastIndex** property specifies the string position at which to start the next match. It is coerced to an integer when used (see 15.10.6.2). This property shall have the attributes { **[[Writable]]: true**, **[[Enumerable]]: false**, **[[Configurable]]: false** }.

NOTE

*Unlike the other standard built-in properties of RegExp instances, **lastIndex** is writable.*

15.11 Error Objects

Instances of Error objects are thrown as exceptions when runtime errors occur. The Error objects may also serve as base objects for user-defined exception classes.

15.11.1 The Error Constructor Called as a Function

When **Error** is called as a function rather than as a constructor, it creates and initialises a new Error object. Thus the function call **Error(...)** is equivalent to the object creation expression **new Error(...)** with the same arguments.

15.11.1.1 Error (message)

The **[[Prototype]]** internal property of the newly constructed object is set to the original Error prototype object, the one that is the initial value of **Error.prototype** (15.11.3.1).

The **[[Class]]** internal property of the newly constructed object is set to **"Error"**.

The **[[Extensible]]** internal property of the newly constructed object is set to **true**.

If the argument *message* is not **undefined**, the **message** own property of the newly constructed object is set to **ToString(message)**. Otherwise, the **message** own property is set to the empty string.

15.11.2 The Error Constructor

When **Error** is called as part of a **new** expression, it is a constructor: it initialises the newly created object.

15.11.2.1 new Error (message)

The **[[Prototype]]** internal property of the newly constructed object is set to the original Error prototype object, the one that is the initial value of **Error.prototype** (15.11.3.1).

The **[[Class]]** internal property of the newly constructed Error object is set to **"Error"**.

The **[[Extensible]]** internal property of the newly constructed object is set to **true**.

If the argument *message* is not **undefined**, the **message** own property of the newly constructed object is set to **ToString(message)**. Otherwise, the **message** own property is set to the empty string.

15.11.3 Properties of the Error Constructor

The value of the **[[Prototype]]** internal property of the Error constructor is the Function prototype object (15.3.4).

Besides the internal properties and the **length** property (whose value is **1**), the Error constructor has the following property:

15.11.3.1 Error.prototype

The initial value of **Error.prototype** is the Error prototype object (15.11.4).

This property has the attributes { **[[Writable]]: false**, **[[Enumerable]]: false**, **[[Configurable]]: false** }.

15.11.4 Properties of the Error Prototype Object

The Error prototype object is itself an Error object (its **[[Class]]** is **"Error"**).

The value of the `[[Prototype]]` internal property of the Error prototype object is the standard built-in Object prototype object (15.2.4).

15.11.4.1 **Error.prototype.constructor**

The initial value of `Error.prototype.constructor` is the built-in `Error` constructor.

15.11.4.2 **Error.prototype.name**

The initial value of `Error.prototype.name` is `"Error"`.

15.11.4.3 **Error.prototype.message**

The initial value of `Error.prototype.message` is the empty string.

15.11.4.4 **Error.prototype.toString ()**

The following steps are taken:

1. Let *O* be the **this** value.
2. If `Type(O)` is not `Object`, throw a **TypeError** exception.
3. Let *name* be the result of calling the `[[Get]]` internal method of *O* with argument `"name"`.
4. If *name* is **undefined**, then let *name* be `"Error"`; else let *name* be `ToString(name)`.
5. Let *msg* be the result of calling the `[[Get]]` internal method of *O* with argument `"message"`.
6. If *msg* is undefined, then let *R* be *msg*.
7. Else, let *R* be the result of concatenating *name*, `" : "`, a single space character, and `ToString(msg)`.
8. Return *R*.

15.11.5 **Properties of Error Instances**

Error instances inherit properties from the Error prototype object and their `[[Class]]` internal property value is `"Error"`. Error instances have no special properties.

15.11.6 **Native Error Types Used in This Standard**

One of the *NativeError* objects below is thrown when a runtime error is detected. All of these objects share the same structure, as described in 15.11.7.

15.11.6.1 **EvalError**

This exception is not generated by this specification. This object remains for compatibility with previous editions of this specification.

15.11.6.2 **RangeError**

Indicates a numeric value has exceeded the allowable range. See 15.4.2.2, 15.4.5.1, 15.7.4.2, 15.7.4.5, 15.7.4.6, and 15.7.4.7, 15.9.5.43.

15.11.6.3 **ReferenceError**

Indicate that an invalid reference value has been detected. See 8.7.1, 8.7.2, 10.2.1, 10.2.1.1.4, 10.2.1.2.4, 11.4.1, and 11.13.1.

15.11.6.4 **SyntaxError**

Indicates that a parsing error has occurred. See 11.1.5, 12.2.1, 12.14.1, 13.1, 15.1.2.1, 15.10.2.2, 15.3.2.1, 15.10.2.5, 15.10.2.9, 15.10.2.15, 15.10.2.19, 15.10.4.1, and 15.12.2.

15.11.6.5 **TypeError**

Indicates the actual type of an operand is different than the expected type. See 8.12.5, 8.12.7, 8.12.8, 8.12.9, 9.9, 9.10, 10.2.1, 10.2.1.1.3, 10.6, 11.2.2, 11.2.3, 11.4.1, 11.8.6, 11.8.7, 11.3.1, 15.2.3.2, 15.2.3.3, 15.2.3.4, 15.2.3.5, 15.2.3.6, 15.2.3.7, 15.2.3.8, 15.2.3.9, 15.2.3.10, 15.2.3.11, 15.2.3.12, 15.2.3.13, 15.2.3.14, 15.2.4.3, 15.3.4.2, 15.3.4.3, 15.3.4.4, 15.3.4.5, 15.3.4.5.2, 15.3.4.5.3, 15.3.5.3, 15.4.4.3, 15.4.4.11, 15.4.4.16, 15.4.4.17, 15.4.4.18, 15.4.4.19, 15.4.4.20, 15.4.4.21, 15.4.4.22, 15.4.5.1, 15.5.4.2, 15.5.4.3, 15.5.4.21, 15.6.4.2, 15.6.4.3, 15.6.4.4, 15.7.4, 15.7.4.2, 15.7.4.4, 15.7.4.8, 15.9.5, 15.9.5.9, 15.9.5.44, 15.10.4.1, 15.10.6, 15.11.4.4 and 15.12.3.

15.11.6.6 **URIError**

Indicates that one of the global URI handling functions was used in a way that is incompatible with its definition. See 15.1.3.

15.11.7 *NativeError* Object Structure

When an ECMAScript implementation detects a runtime error, it throws an instance of one of the *NativeError* objects defined in 15.11.6. Each of these objects has the structure described below, differing only in the name used as the constructor name instead of *NativeError*, in the **name** property of the prototype object, and in the implementation-defined **message** property of the prototype object.

For each error object, references to *NativeError* in the definition should be replaced with the appropriate error object name from 15.11.6.

15.11.7.1 *NativeError* Constructors Called as Functions

When a *NativeError* constructor is called as a function rather than as a constructor, it creates and initialises a new object. A call of the object as a function is equivalent to calling it as a constructor with the same arguments.

15.11.7.2 *NativeError* (message)

The `[[Prototype]]` internal property of the newly constructed object is set to the prototype object for this error constructor. The `[[Class]]` internal property of the newly constructed object is set to **"Error"**. The `[[Extensible]]` internal property of the newly constructed object is set to **true**.

If the argument *message* is not **undefined**, the **message** own property of the newly constructed object is set to `ToString(message)`.

15.11.7.3 The *NativeError* Constructors

When a *NativeError* constructor is called as part of a **new** expression, it is a constructor: it initialises the newly created object.

15.11.7.4 New *NativeError* (message)

The `[[Prototype]]` internal property of the newly constructed object is set to the prototype object for this *NativeError* constructor. The `[[Class]]` internal property of the newly constructed object is set to **"Error"**. The `[[Extensible]]` internal property of the newly constructed object is set to **true**.

If the argument *message* is not **undefined**, the **message** property of the newly constructed object is set to `ToString(message)`. Otherwise, the **message** own property is set to the empty string.

15.11.7.5 Properties of the *NativeError* Constructors

The value of the `[[Prototype]]` internal property of a *NativeError* constructor is the Function prototype object (15.3.4).

Besides the internal properties and the **length** property (whose value is **1**), each *NativeError* constructor has the following property:

15.11.7.6 *NativeError*.prototype

The initial value of *NativeError*.**prototype** is a *NativeError* prototype object (15.11.7.7). Each *NativeError* constructor has a separate prototype object.

This property has the attributes { `[[Writable]]`: **false**, `[[Enumerable]]`: **false**, `[[Configurable]]`: **false** }.

15.11.7.7 Properties of the *NativeError* Prototype Objects

Each *NativeError* prototype object is an Error object (its `[[Class]]` is **"Error"**).

The value of the `[[Prototype]]` internal property of each *NativeError* prototype object is the standard built-in Error prototype object (15.11.4).

15.11.7.8 *NativeError*.prototype.constructor

The initial value of the **constructor** property of the prototype for a given *NativeError* constructor is the *NativeError* constructor function itself (15.11.7).

15.11.7.9 *NativeError*.prototype.name

The initial value of the **name** property of the prototype for a given *NativeError* constructor is the name of the constructor (the name used instead of *NativeError*).

15.11.7.10 *NativeError*.prototype.message

The initial value of the **message** property of the prototype for a given *NativeError* constructor is the empty string.

NOTE

*The prototypes for the NativeError constructors do not themselves provide a **toString** function, but instances of errors will inherit it from the Error prototype object.*

15.11.7.11 Properties of *NativeError* Instances

NativeError instances inherit properties from their *NativeError* prototype object and their `[[Class]]` internal property value is "**Error**". *NativeError* instances have no special properties.

15.12 The JSON Object

The **JSON** object is a single object that contains two functions, **parse** and **stringify**, that are used to parse and construct JSON texts. The JSON Data Interchange Format is described in RFC 4627 <<http://www.ietf.org/rfc/rfc4627.txt?number=4627>>. The JSON interchange format used in this specification is exactly that described by RFC 4627 with two exceptions:

- The top level *JSONText* production of the ECMAScript JSON grammar may consist of any *JSONValue* rather than being restricted to being a *JSONObject* or a *JSONArray* as specified by RFC 4627.
- Conforming implementations of **JSON.parse** and **JSON.stringify** must support the exact interchange format described in this specification without any deletions or extensions to the format. This differs from RFC 4627 which permits a JSON parser to accept non-JSON forms and extensions.

The value of the `[[Prototype]]` internal property of the JSON object is the standard built-in Object prototype object (15.2.4). The value of the `[[Class]]` internal property of the JSON object is "**JSON**". The value of the `[[Extensible]]` internal property of the JSON object is set to **true**.

The JSON object does not have a `[[Construct]]` internal property; it is not possible to use the JSON object as a constructor with the **new** operator.

The JSON object does not have a `[[Call]]` internal property; it is not possible to invoke the JSON object as a function.

15.12.1 The JSON Grammar

JSON.stringify produces a string that conforms to the following JSON grammar. **JSON.parse** accepts a string that conforms to the JSON grammar.

15.12.1.1 The JSON Lexical Grammar

JSON is similar to ECMAScript source text in that it consists of a sequence of characters conforming to the rules of *SourceCharacter*. The JSON Lexical Grammar defines the tokens that make up a JSON text similar to the manner that the ECMAScript lexical grammar defines the tokens of an ECMAScript source text. The JSON Lexical grammar only recognizes the white space character specified by the production *JSONWhiteSpace*. The JSON lexical grammar shares some productions with the ECMAScript lexical grammar. All nonterminal symbols of the grammar that do not begin with the characters "JSON" are defined by productions of the ECMAScript lexical grammar.

Syntax

JSONWhiteSpace ::

<TAB>
<CR>
<LF>
<SP>

JSONString ::

"*JSONStringCharacters*_{opt}"

JSONStringCharacters ::

JSONStringCharacter *JSONStringCharacters*_{opt}

JSONStringCharacter ::

SourceCharacter **but not** double-quote " **or** backslash \ **or** U+0000 thru U+001F
\ *JSONEscapeSequence*

JSONEscapeSequence ::

JSONEscapeCharacter
UnicodeEscapeSequence

JSONEscapeCharacter :: **one of**

" / \ b f n r t

JSONNumber ::

-_{opt} *DecimalIntegerLiteral* *JSONFraction*_{opt} *ExponentPart*_{opt}

JSONFraction ::

. *DecimalDigits*

JSONNullLiteral ::

NullLiteral

JSONBooleanLiteral ::

BooleanLiteral

15.12.1.2 The JSON Syntactic Grammar

The JSON Syntactic Grammar defines a valid JSON text in terms of tokens defined by the JSON lexical grammar. The goal symbol of the grammar is *JSONValue*.

Syntax

JSONText :

JSONValue

JSONValue :

JSONNullLiteral
JSONBooleanLiteral
JSONObject
JSONArray
JSONString
JSONNumber

JSONObject :

{ }
{ *JSONMemberList* }

JSONMember :

JSONString : *JSONValue*

JSONMemberList :

JSONMember
JSONMemberList , *JSONMember*

JSONArray :

[]
[*JSONElementList*]

JSONElementList :

JSONValue
JSONElementList , *JSONValue*

15.12.2 parse (text [, reviver])

The **parse** function parses a JSON text (a JSON formatted string) and produces an ECMAScript value. The JSON format is a restricted form of ECMAScript literal. JSON objects are realized as ECMAScript objects. JSON Arrays are realized as ECMAScript arrays. JSON strings, numbers, booleans, and null are realized as ECMAScript strings, numbers, booleans, and null. JSON uses a more limited set of white space characters than *WhiteSpace* and allows Unicode code points U+2028 and U+2029 to directly appear in *JSONString* literals without using an escape sequence. The process of parsing is similar to 11.1.4 and 11.1.5 as constrained by the JSON grammar.

The optional **reviver** parameter is a function that takes two parameters, (key, value). It can filter and transform the results. It is called with each of the key/value pairs produced by the parse, and its return value is used instead of the original value. If it returns what it received, the structure is not modified. If it returns **undefined** then the property is deleted from the result.

1. Let *JText* be ToString(*text*).
2. Parse *JText* using the grammars in 15.12.1. Throw a **SyntaxError** exception if the *JText* did not conform to the JSON grammar for the goal symbol *JSONText*.
3. Let *unfiltered* be the result of parsing and evaluating *JText* as if it was the source text of an ECMAScript *program* but using *JSONString* in place of *StringLiteral*. Note that since *JText* conforms to the JSON grammar this result will be either a primitive value or an object that is defined by either an *ArrayLiteral* or an *ObjectLiteral*.
4. If IsCallable(*reviver*) is **true**, then
 - a. Let *root* be a new object created as if by the expression **new Object()**, where **Object** is the standard built-in constructor with that name.
 - b. Call the [[DefineOwnProperty]] internal method of *root* with the empty string, the PropertyDescriptor {[[Value]]: *unfiltered*, [[Writable]]: **true**, [[Enumerable]]: **true**, [[Configurable]]: **true**}, and **false** as arguments.
 - c. Return the result of calling the abstract operation *Walk*, passing *root* and the empty string. The abstract operation *Walk* is described below.
5. Else
 - a. Return *unfiltered*.

The abstract operation *Walk* is a recursive abstract operation that takes two parameters: a *holder* object and the string *name* of a property in that object. *Walk* uses the value of *reviver* that was originally passed to the above parse function.

1. Let *val* be the result of calling the [[Get]] internal method of *holder* with argument *name*.
2. If *val* is an object, then
 - a. If the [[Class]] internal property of *val* is **"Array"**
 - i. Set *I* to 0.
 - ii. Let *len* be the result of calling the [[Get]] internal method of *val* with argument **"length"**.
 - iii. Repeat while *I* < *len*,
 1. Let *newElement* be the result of calling the abstract operation *walk*, passing *val* and ToString(*I*).
 2. If *newElement* is **undefined**, then
 - a. Call the [[Delete]] internal method of *val* with ToString(*I*) and **false** as arguments.
 3. Else
 - a. Call the [[DefineOwnProperty]] internal method of *val* with arguments ToString(*I*), the Property Descriptor {[[Value]]: *newElement*, [[Writable]]: **true**, [[Enumerable]]: **true**, [[Configurable]]: **true**}, and **false**.
 4. Add 1 to *I*.

- b. Else
 - i. Let *keys* be an internal List of Strings consisting of the names of all the own properties of *val* whose `[[Enumerable]]` attribute is **true**. The ordering of the strings should be the same as that used by the **Object.keys** standard built-in function.
 - ii. For each string *P* in *keys* do,
 1. Let *newElement* be the result of calling the abstract operation *walk*, passing *val* and *P*.
 2. If *newElement* is **undefined**, then
 - a. Call the `[[Delete]]` internal method of *val* with *P* and **false** as arguments.
 3. Else
 - a. Call the `[[DefineOwnProperty]]` internal method of *val* with arguments *P*, the Property Descriptor `{[[Value]]: newElement, [[Writable]]: true, [[Enumerable]]: true, [[Configurable]]: true}`, and **false**.
3. Return the result of calling the `[[Call]]` internal method of *reviver* passing *holder* as the **this** value and with an argument list consisting of *name* and *val*.

NOTE

In the case where there are duplicate name strings within an object, lexically preceding values for the same key shall be overwritten.

It is not permitted for a conforming implementation of **JSON.parse** to extend the JSON grammars. If an implementation wishes to support a modified or extended JSON interchange format it must do so by defining a different parse function.

15.12.3 stringify (value [, replacer [, space]])

The `stringify` function produces a JSON formatted string that captures information from an ECMAScript value. It can take three parameters. The first parameter is required. The *value* parameter is an ECMAScript value, which is usually an object or array, although it can also be a string, boolean, number or **null**. The optional *replacer* parameter is either a function that alters the way objects and arrays are stringified, or an array of strings that acts as a white list for selecting the keys that will be stringified. The optional *space* parameter is a string or number that allows the result to have white space injected into it to improve human readability.

These are the steps in stringifying an object:

1. Let *stack* be an empty List.
2. Let *indent* be the empty string.
3. Let *PropertyList* and *ReplacerFunction* be **undefined**.
4. If `Type(replacer)` is object, then
 - a. If `IsCallable(replacer)` is **true**, then
 - i. Let *ReplacerFunction* be *replacer*.
 - b. Else if the `[[Class]]` internal property of *replacer* is **"Array"**, then
 - i. Let *PropertyList* be an empty internal List
 - ii. For each value *v* of a property of *replacer* that has an array index name. The properties are enumerated in the ascending array index order of their names.
 1. If `Type(v)` is string then append *v* to *PropertyList*.
 2. Else if `Type(v)` is number then append `Tostring(v)` to *PropertyList*.
 3. If `Type(v)` is object then,
 - a. If the `[[Class]]` internal property of *v* is **"String"** or **"Number"** then append `Tostring(v)` to *PropertyList*.
5. If `Type(space)` is object then,
 - a. If the `[[Class]]` internal property of *space* is **"Number"** then,
 - i. Let *space* be `ToNumber(space)`.
 - b. Else if the `[[Class]]` internal property of *space* is **"String"** then,
 - i. Let *space* be `Tostring(space)`.
6. If `Type(space)` is number
 - a. Let *space* be `min(10, ToInteger(space))`.
 - b. Set *gap* to a string containing *space* space characters. This will be the empty string if *space* is less than 1.
7. Else if `Type(space)` is string

- a. If the number of characters in *space* is 10 or less, set *gap* to *space* otherwise set *gap* to a string consisting of the first 10 characters of *space*.
8. Else
 - a. Set *gap* to the empty string.
9. Let *wrapper* be a new object created as if by the expression **new Object()**, where **Object** is the standard built-in constructor with that name.
10. Call the `[[DefineOwnProperty]]` internal method of *wrapper* with arguments the empty string, the Property Descriptor `{[[Value]]: value, [[Writable]]: true, [[Enumerable]]: true, [[Configurable]]: true}`, and **false**.
11. Return the result of calling the abstract operation *Str* with the empty string and *wrapper*.

The abstract operation *Str(key, holder)* has access to *PropertyList* and *ReplacerFunction* from the invocation of the **stringify** method. Its algorithm is as follows:

1. Let *value* be the result of calling the `[[Get]]` internal method of *holder* with argument *key*.
2. If `Type(value)` is object, then
 - a. Let *toJSON* be the result of calling the `[[Get]]` internal method of *value* with argument **"toJSON"**.
 - b. If `IsCallable(toJSON)` is **true**
 - i. Let *value* be the result of calling the `[[Call]]` internal method of *toJSON* passing *value* as the **this** value and with an argument list consisting of *key*.
3. If *ReplacerFunction* is not **undefined**, then
 - a. Let *value* be the result of calling the `[[Call]]` internal method of *ReplacerFunction* passing *holder* as the **this** value and with an argument list consisting of *key* and *value*.
4. If `Type(value)` is object then,
 - a. If the `[[Class]]` internal property of *value* is **"Number"** then,
 - i. Let *value* be `ToNumber(value)`.
 - b. Else if the `[[Class]]` internal property of *value* is **"String"** then,
 - i. Let *value* be `ToString(value)`.
 - c. Else if the `[[Class]]` internal property of *value* is **"Boolean"** then,
 - i. Let *value* be the value of the `[[PrimitiveValue]]` internal property of *value*.
5. If *value* is **null** then return **"null"**.
6. If *value* is **true** then return **"true"**.
7. If *value* is **false** then return **"false"**.
8. If `Type(value)` is string, then return the result of calling the abstract operation *Quote* with argument *value*.
9. If `Type(value)` is number
 - a. If *value* is finite then return `ToString(value)`.
 - b. Else, return **"null"**.
10. If `Type(value)` is object, and `IsCallable(value)` is **false**
 - a. If the `[[Class]]` internal property of *value* is **"Array"** then
 - i. Return the result of calling the abstract operation *JA* with argument *value*.
 - b. Else, return the result of calling the abstract operation *JO* with argument *value*.
11. Return **undefined**.

The abstract operation *Quote(value)* wraps a string value in double quotes and escapes characters within it.

1. Let *product* be the double quote character.
2. For each character *C* in *value*
 - a. If *C* is the double quote character or the backslash character
 - i. Let *product* be the concatenation of *product* and the backslash character.
 - ii. Let *product* be the concatenation of *product* and *C*.
 - b. Else If *C* is backspace, formfeed, newline, carriage return, or tab
 - i. Let *product* be the concatenation of *product* and the backslash character.

- ii. Let *abbrev* be the character corresponding to the value of *C* in the following table:

| | |
|-----------------|--------------|
| backspace | " b " |
| formfeed | " f " |
| newline | " n " |
| carriage return | " r " |
| tab | " t " |
 - iii. Let *product* be the concatenation of *product* and *abbrev*.
 - c. Else If *C* is a control character having a code unit value less than the space character
 - i. Let *product* be the concatenation of *product* and the backslash character.
 - ii. Let *product* be the concatenation of *product* and "**u**".
 - iii. Let *hex* be the result of converting the numeric code unit value of *C* to a string of 4 base 16 digits.
 - iv. Let *product* be the concatenation of *product* and *hex*.
 - d. Else
 - i. Let *product* be the concatenation of *product* and *C*.
3. Let *product* be the concatenation of *product* and the double quote character.
 4. Return *product*.

The abstract operation *JO(value)* serializes an object. It has access to the *stack*, *indent*, *gap*, *PropertyList*, *ReplacerFunction*, and *space* of the invocation of the stringify method.

1. If *stack* contains *value* then throw a **TypeError** exception because the structure is cyclical.
2. Append *value* to *stack*.
3. Let *stepback* be *indent*.
4. Let *indent* be the concatenation of *indent* and *gap*.
5. If *PropertyList* is not **undefined**, then
 - a. Let *K* be *PropertyList*.
6. Else
 - a. Let *K* be an internal List of strings consisting of the names of all the own properties of *value* whose `[[Enumerable]]` attribute is **true**. The ordering of the strings should be the same as that used by the **Object.keys** standard built-in function.
7. Let *partial* be an empty List.
8. For each element *P* of *K*.
 - a. Let *strP* be the result of calling the abstract operation *Str* with arguments *P* and *value*.
 - b. If *strP* is not **undefined**
 - i. Let *member* be the result of calling the abstract operation *Quote* with argument *P*.
 - ii. Let *member* be the concatenation of *member* and the colon character.
 - iii. If *gap* is not the empty string
 1. Let *member* be the concatenation of *member* and the *space* character.
 - iv. Let *member* be the concatenation of *member* and *strP*.
 - v. Append *member* to *partial*.
9. If *partial* is empty, then
 - a. Let *final* be "**{ }**".
10. Else
 - a. If *gap* is the empty string
 - i. Let *properties* be a string formed by concatenating all the element strings of *partial* with each adjacent pair of strings separated with the comma character. A comma is not inserted either before the first string or after the last string.
 - ii. Let *final* be the result of concatenating "**{ "**, *properties*, and " **}**".
 - b. Else *gap* is not the empty string
 - i. Let *separator* be the result of concatenating the comma character, the line feed character, and *indent*.
 - ii. Let *properties* be a string formed by concatenating all the element strings of *partial* with each adjacent pair of strings separated with *separator*. The *separator* string is not inserted either before the first string or after the last string.
 - iii. Let *final* be the result of concatenating "**{ "**, the line feed character, *indent*, *properties*, the line feed character, *stepback*, and " **}**".
11. Remove the last element of *stack*.

12. Let *indent* be *stepback*.
13. Return *final*.

The abstract operation *JA(value)* serializes an array. It has access to the *stack*, *indent*, *gap*, and *space* of the invocation of the stringify method. The representation of arrays includes only the elements between zero and *array.length* – 1. Named properties are excluded from the stringification. An array is stringified as an open left bracket, elements separated by comma, and a closing right bracket.

1. If *stack* contains *value* then throw a **TypeError** exception because the structure is cyclical.
2. Append *value* to *stack*.
3. Let *stepback* be *indent*.
4. Let *indent* be the concatenation of *indent* and *gap*.
5. Let *partial* be an empty List.
6. Let *len* be the result of calling the `[[Get]]` internal method of *value* with argument "**length**".
7. Let *index* be 0.
8. Repeat while *index* < *len*
 - a. Let *strP* be the result of calling the abstract operation *Str* with arguments `ToString(index)` and *value*.
 - b. If *strP* is **undefined**
 - i. Append "**null**" to *partial*.
 - c. Else
 - i. Append *strP* to *partial*.
 - d. Increment *index* by 1.
9. If *partial* is empty ,then
 - a. Let *final* be " [] ".
10. Else
 - a. If *gap* is the empty string
 - i. Let *properties* be a string formed by concatenating all the element strings of *partial* with each adjacent pair of strings separated with the comma character. A comma is not inserted either before the first string or after the last string.
 - ii. Let *final* be the result of concatenating " [, *properties*, and] ".
 - b. Else
 - i. Let *separator* be the result of concatenating the comma character, the line feed character, and *indent*.
 - ii. Let *properties* be a string formed by concatenating all the element strings of *partial* with each adjacent pair of strings separated with *separator*. The *separator* string is not inserted either before the first string or after the last string.
 - iii. Let *final* be the result of concatenating " [, the line feed character, *indent*, *properties*, the line feed character, *stepback*, and] ".
11. Remove the last element of *stack*.
12. Let *indent* be *stepback*.
13. Return *final*.

NOTE

JSON structures are allowed to be nested to any depth, but they must be acyclic. If *value* is or contains a cyclic structure, then the stringify function must throw a **TypeError** exception. This is an example of a value that cannot be stringified:

```
a = [];  
a[0] = a;  
my_text = JSON.stringify(a); // This must throw an TypeError.
```

The **null** value is rendered in JSON text as the string `null`.

The **true** value is rendered in JSON text as the string `true`.

The **false** value is rendered in JSON text as the string `false`.

String values are wrapped in double quotes. The characters `"` and `\` are escaped with `\` prefixes. Control characters are replaced with escape sequences `\uHHHH`, or with the shorter forms, `\b` (backspace), `\f` (formfeed), `\n` (newline), `\r` (carriage return), `\t` (tab).

Finite numbers are stringified as if by **String(number)**. **NaN** and Infinity regardless of sign are represented as the string **null**.

Values that do not have a JSON representation (such as **undefined** and functions) do not produce a string. Instead they produce the undefined value. In arrays these values are represented as the string **null**. In objects an unrepresentable value causes the property to be excluded from stringification.

An object is rendered as an opening left brace followed by zero or more properties, separated with commas, closed with a right brace. A property is a quoted string representing the key or property name, a colon, and then the stringified property value. An array is rendered as an opening left bracket followed by zero or more values, separated with commas, closed with a right bracket.

DRAFT

16 Errors

An implementation must report most errors at the time the relevant ECMAScript language construct is evaluated. An *early error* is an error that can be detected and reported prior to the evaluation of any construct in the *Program* containing the error. An implementation must report early errors in a *Program* prior to the first evaluation of that *Program*. Early errors in **eval** code are reported at the time **eval** is called but prior to evaluation of any construct within the **eval** code. All errors that are not early errors are runtime errors.

An implementation must treat any instance of the following kinds of errors as an early error:

- Any syntax error.
- Attempts to define an *ObjectLiteral* that has multiple **get** property assignments with the same name or multiple **set** property assignments with the same name.
- Attempts to define an *ObjectLiteral* that has both a data property assignment and a **get** or **set** property assignment with the same name.
- Errors in regular expression literals that are not implementation-defined syntax extensions.
- Attempts in strict mode code to define an *ObjectLiteral* that has multiple data property assignments with the same name.
- The occurrence of a *WithStatement* in strict mode code.
- The occurrence of an *Identifier* value appearing more than once within a *FormalParameterList* of an individual strict mode *FunctionDeclaration* or *FunctionExpression*.
- Improper uses of **return**, **break**, and **continue**.
- Attempts to call `PutValue` on any value for which an early determination can be made that the value is not a Reference (for example, executing the assignment statement `3=4`).

An implementation shall not treat other kinds of errors as early errors even if the compiler can prove that a construct cannot execute without error under any circumstances. An implementation may issue an early warning in such a case, but it should not report the error until the relevant construct is actually executed.

An implementation shall report all errors as specified, except for the following:

- An implementation may extend program syntax and regular expression pattern or flag syntax. To permit this, all operations (such as calling **eval**, using a regular expression literal, or using the **Function** or **RegExp** constructor) that are allowed to throw **SyntaxError** are permitted to exhibit implementation-defined behaviour instead of throwing **SyntaxError** when they encounter an implementation-defined extension to the program syntax or regular expression pattern or flag syntax.
- An implementation may provide additional types, values, objects, properties, and functions beyond those described in this specification. This may cause constructs (such as looking up a variable in the global scope) to have implementation-defined behaviour instead of throwing an error (such as **ReferenceError**).
- An implementation may define behaviour other than throwing **RangeError** for **toFixed**, **toExponential**, and **toPrecision** when the *fractionDigits* or *precision* argument is outside the specified range.

Annex A
(Informative)

Grammar Summary

A.1 Lexical Grammar

| | |
|---|--------------|
| <i>SourceCharacter</i> :: any Unicode code unit | See clause 6 |
| <i>InputElementDiv</i> :: <i>WhiteSpace</i> <i>LineTerminator</i> <i>Comment</i> <i>Token</i> <i>DivPunctuator</i> | See clause 7 |
| <i>InputElementRegExp</i> :: <i>WhiteSpace</i> <i>LineTerminator</i> <i>Comment</i> <i>Token</i> <i>RegularExpressionLiteral</i> | See clause 7 |
| <i>WhiteSpace</i> :: <TAB> <VT> <FF> <SP> <NBSP> <BOM> <USP> | See 7.2 |
| <i>LineTerminator</i> :: <LF> <CR> <LS> <PS> | See 7.3 |
| <i>LineTerminatorSequence</i> :: <LF> <CR> [lookahead ≠ <LF>] <LS> <PS> <CR> <LF> | See 7.3 |
| <i>Comment</i> :: <i>MultiLineComment</i> <i>SingleLineComment</i> | See 7.4 |

| | |
|---|---------|
| <i>MultiLineComment</i> :: /* <i>MultiLineCommentChars</i> _{opt} */ | See 7.4 |
| <i>MultiLineCommentChars</i> :: <i>MultiLineNotAsteriskChar</i> <i>MultiLineCommentChars</i> _{opt} * <i>PostAsteriskCommentChars</i> _{opt} | See 7.4 |
| <i>PostAsteriskCommentChars</i> :: <i>MultiLineNotForwardSlashOrAsteriskChar</i> <i>MultiLineCommentChars</i> _{opt} * <i>PostAsteriskCommentChars</i> _{opt} | See 7.4 |
| <i>MultiLineNotAsteriskChar</i> :: <i>SourceCharacter</i> but not asterisk * | See 7.4 |
| <i>MultiLineNotForwardSlashOrAsteriskChar</i> :: <i>SourceCharacter</i> but not forward-slash / or asterisk * | See 7.4 |
| <i>SingleLineComment</i> :: // <i>SingleLineCommentChars</i> _{opt} | See 7.4 |
| <i>SingleLineCommentChars</i> :: <i>SingleLineCommentChar</i> <i>SingleLineCommentChars</i> _{opt} | See 7.4 |
| <i>SingleLineCommentChar</i> :: <i>SourceCharacter</i> but not <i>LineTerminator</i> | See 7.4 |
| <i>Token</i> :: <i>IdentifierName</i> <i>Punctuator</i> <i>NumericLiteral</i> <i>StringLiteral</i> | See 7.5 |
| <i>Identifier</i> :: <i>IdentifierName</i> but not <i>ReservedWord</i> | See 7.6 |
| <i>IdentifierName</i> :: <i>IdentifierStart</i> <i>IdentifierName</i> <i>IdentifierPart</i> | See 7.6 |
| <i>IdentifierStart</i> :: <i>UnicodeLetter</i> \$ $\bar{\quad}$ <i>UnicodeEscapeSequence</i> | See 7.6 |

IdentifierPart :: See 7.6
IdentifierStart
UnicodeCombiningMark
UnicodeDigit
UnicodeConnectorPunctuation
 <ZWJ>
 <ZWJ>

UnicodeLetter See 7.6
 any character in the Unicode categories “Uppercase letter (Lu)”, “Lowercase letter (Ll)”, “Titlecase letter (Lt)”, “Modifier letter (Lm)”, “Other letter (Lo)”, or “Letter number (Nl)”.

UnicodeCombiningMark See 7.6
 any character in the Unicode categories “Non-spacing mark (Mn)” or “Combining spacing mark (Mc)”

UnicodeDigit See 7.6
 any character in the Unicode category “Decimal number (Nd)”

UnicodeConnectorPunctuation See 7.6
 any character in the Unicode category “Connector punctuation (Pc)”

ReservedWord :: See 7.6.1
Keyword
FutureReservedWord
NullLiteral
BooleanLiteral

Keyword :: one of See 7.6.1.1

| | | | |
|-----------------|-----------------|-------------------|---------------|
| break | do | instanceof | typeof |
| case | else | new | var |
| catch | finally | return | void |
| continue | for | switch | while |
| debugger | function | this | with |
| default | if | throw | |
| delete | in | try | |

FutureReservedWord :: one of See 7.6.1.2

| | | | |
|--------------|---------------|----------------|--------------|
| class | enum | extends | super |
| const | export | Import | |

or in strict mode code **one of**

| | | | |
|-------------------|----------------|------------------|---------------|
| implements | let | private | public |
| interface | package | protected | static |
| yield | | | |

Punctuator :: one of See 7.7

| | | | | | |
|-----------------|-----------------|---------------------|--------------|-------------|--------------|
| { | } | (|) | [|] |
| . | ; | , | < | > | <= |
| >= | == | != | === | !== | |
| + | - | * | % | ++ | -- |
| << | >> | >>> | & | | ^ |

| | | | | | |
|-----|------|----|----|----|-----|
| ! | ~ | && | | ? | : |
| = | += | -= | *= | %= | <<= |
| >>= | >>>= | &= | = | ^= | |

DivPunctuator :: one of
/ /= See 7.7

Literal :: See 7.8
NullLiteral
BooleanLiteral
NumericLiteral
StringLiteral

NullLiteral :: See 7.8.1
null

BooleanLiteral :: See 7.8.2
true
false

NumericLiteral :: See 7.8.3
DecimalLiteral
HexIntegerLiteral

DecimalLiteral :: See 7.8.3
DecimalIntegerLiteral . *DecimalDigits*_{opt} *ExponentPart*_{opt}
. *DecimalDigits* *ExponentPart*_{opt}
DecimalIntegerLiteral *ExponentPart*_{opt}

DecimalIntegerLiteral :: See 7.8.3
0
NonZeroDigit *DecimalDigits*_{opt}

DecimalDigits :: See 7.8.3
DecimalDigit
DecimalDigits *DecimalDigit*

DecimalDigit :: one of See 7.8.3
0 1 2 3 4 5 6 7 8 9

ExponentIndicator :: one of See 7.8.3
e E

SignedInteger :: See 7.8.3
DecimalDigits
+ *DecimalDigits*
- *DecimalDigits*

| | |
|---|------------------|
| <i>HexIntegerLiteral</i> :: 0x <i>HexDigit</i> 0X <i>HexDigit</i> <i>HexIntegerLiteral</i> <i>HexDigit</i> | <i>See</i> 7.8.3 |
| <i>HexDigit</i> :: one of 0 1 2 3 4 5 6 7 8 9 a b c d e f A B C D E F | <i>See</i> 7.8.3 |
| <i>StringLiteral</i> :: " <i>DoubleStringCharacters</i> _{opt} " ' <i>SingleStringCharacters</i> _{opt} ' | <i>See</i> 7.8.4 |
| <i>DoubleStringCharacters</i> :: <i>DoubleStringCharacter</i> <i>DoubleStringCharacters</i> _{opt} | <i>See</i> 7.8.4 |
| <i>SingleStringCharacters</i> :: <i>SingleStringCharacter</i> <i>SingleStringCharacters</i> _{opt} | <i>See</i> 7.8.4 |
| <i>DoubleStringCharacter</i> :: <i>SourceCharacter</i> but not double-quote " or backslash \ or <i>LineTerminator</i> \ <i>EscapeSequence</i> <i>LineContinuation</i> | <i>See</i> 7.8.4 |
| <i>SingleStringCharacter</i> :: <i>SourceCharacter</i> but not single-quote ' or backslash \ or <i>LineTerminator</i> \ <i>EscapeSequence</i> <i>LineContinuation</i> | <i>See</i> 7.8.4 |
| <i>LineContinuation</i> :: \ <i>LineTerminatorSequence</i> | <i>See</i> 7.8.4 |
| <i>EscapeSequence</i> :: <i>CharacterEscapeSequence</i> 0 [lookahead ≠ <i>DecimalDigit</i>] <i>HexEscapeSequence</i> <i>UnicodeEscapeSequence</i> | <i>See</i> 7.8.4 |
| <i>CharacterEscapeSequence</i> :: <i>SingleEscapeCharacter</i> <i>NonEscapeCharacter</i> | <i>See</i> 7.8.4 |
| <i>SingleEscapeCharacter</i> :: one of ' " \ b f n r t v | <i>See</i> 7.8.4 |
| <i>NonEscapeCharacter</i> :: <i>SourceCharacter</i> but not <i>EscapeCharacter</i> or <i>LineTerminator</i> | <i>See</i> 7.8.4 |
| <i>EscapeCharacter</i> :: <i>SingleEscapeCharacter</i> <i>DecimalDigit</i> x u | <i>See</i> 7.8.4 |
| <i>HexEscapeSequence</i> :: x <i>HexDigit</i> <i>HexDigit</i> | <i>See</i> 7.8.4 |

| | |
|--|------------------|
| <i>UnicodeEscapeSequence</i> :: <u>u</u> <i>HexDigit HexDigit HexDigit HexDigit</i> | <i>See 7.8.4</i> |
| <i>RegularExpressionLiteral</i> :: / <i>RegularExpressionBody</i> / <i>RegularExpressionFlags</i> | <i>See 7.8.5</i> |
| <i>RegularExpressionBody</i> :: <i>RegularExpressionFirstChar</i> <i>RegularExpressionChars</i> | <i>See 7.8.5</i> |
| <i>RegularExpressionChars</i> :: [empty] <i>RegularExpressionChars</i> <i>RegularExpressionChar</i> | <i>See 7.8.5</i> |
| <i>RegularExpressionFirstChar</i> :: <i>RegularExpressionNonTerminator</i> but not * or \ or / or [<i>RegularExpressionBackslashSequence</i> <i>RegularExpressionClass</i> | <i>See 7.8.5</i> |
| <i>RegularExpressionChar</i> :: <i>RegularExpressionNonTerminator</i> but not \ or / or [<i>RegularExpressionBackslashSequence</i> <i>RegularExpressionClass</i> | <i>See 7.8.5</i> |
| <i>RegularExpressionBackslashSequence</i> :: \ <i>NonTerminator</i> | <i>See 7.8.5</i> |
| <i>RegularExpressionNonTerminator</i> :: <i>SourceCharacter</i> but not <i>LineTerminator</i> | <i>See 7.8.5</i> |
| <i>RegularExpressionClass</i> :: [<i>RegularExpressionClassChars</i>] | <i>See 7.8.5</i> |
| <i>RegularExpressionClassChars</i> :: [empty] <i>RegularExpressionClassChars</i> <i>RegularExpressionClassChar</i> | <i>See 7.8.5</i> |
| <i>RegularExpressionClassChar</i> :: <i>RegularExpressionNonTerminator</i> but not] or \ <i>RegularExpressionBackslashSequence</i> | <i>See 7.8.5</i> |
| <i>RegularExpressionFlags</i> :: [empty] <i>RegularExpressionFlags</i> <i>IdentifierPart</i> | <i>See 7.8.5</i> |

A.2 Number Conversions

| | |
|--|-----------|
| <i>StringNumericLiteral</i> ::: <i>StrWhiteSpace</i> _{opt} <i>StrWhiteSpace</i> _{opt} <i>StrNumericLiteral</i> <i>StrWhiteSpace</i> _{opt} | See 9.3.1 |
| <i>StrWhiteSpace</i> ::: <i>StrWhiteSpaceChar</i> <i>StrWhiteSpace</i> _{opt} | See 9.3.1 |
| <i>StrWhiteSpaceChar</i> ::: <i>WhiteSpace</i> <i>LineTerminator</i> | See 9.3.1 |
| <i>StrNumericLiteral</i> ::: <i>StrDecimalLiteral</i> <i>HexIntegerLiteral</i> | See 9.3.1 |
| <i>StrDecimalLiteral</i> ::: <i>StrUnsignedDecimalLiteral</i> + <i>StrUnsignedDecimalLiteral</i> - <i>StrUnsignedDecimalLiteral</i> | See 9.3.1 |
| <i>StrUnsignedDecimalLiteral</i> ::: Infinity <i>DecimalDigits</i> . <i>DecimalDigits</i> _{opt} <i>ExponentPart</i> _{opt} . <i>DecimalDigits</i> <i>ExponentPart</i> _{opt} <i>DecimalDigits</i> <i>ExponentPart</i> _{opt} | See 9.3.1 |
| <i>DecimalDigits</i> ::: <i>DecimalDigit</i> <i>DecimalDigits</i> <i>DecimalDigit</i> | See 9.3.1 |
| <i>DecimalDigit</i> ::: one of 0 1 2 3 4 5 6 7 8 9 | See 9.3.1 |
| <i>ExponentPart</i> ::: <i>ExponentIndicator</i> <i>SignedInteger</i> | See 9.3.1 |
| <i>ExponentIndicator</i> ::: one of e E | See 9.3.1 |
| <i>SignedInteger</i> ::: <i>DecimalDigits</i> + <i>DecimalDigits</i> - <i>DecimalDigits</i> | See 9.3.1 |
| <i>HexIntegerLiteral</i> ::: 0x <i>HexDigit</i> 0X <i>HexDigit</i> <i>HexIntegerLiteral</i> <i>HexDigit</i> | See 9.3.1 |

HexDigit ::: **one of** See 9.3.1
0 1 2 3 4 5 6 7 8 9 a b c d e f A B C D E F

A.3 Expressions

PrimaryExpression : See 11.1
this
Identifier
Literal
ArrayLiteral
ObjectLiteral
(*Expression*)

ArrayLiteral : See 11.1.4
[*Elision_{opt}*]
[*ElementList*]
[*ElementList* , *Elision_{opt}*]

ElementList : See 11.1.4
Elision_{opt} *AssignmentExpression*
ElementList , *Elision_{opt}* *AssignmentExpression*

Elision : See 11.1.4
,
Elision ,

ObjectLiteral : See 11.1.5
{ }
{ *PropertyNameAndValueList* }
{ *PropertyNameAndValueList* , }

PropertyNameAndValueList : See 11.1.5
PropertyAssignment
PropertyNameAndValueList , *PropertyAssignment*

PropertyAssignment : See 11.1.5
PropertyName : *AssignmentExpression*
get *PropertyName* () { *FunctionBody* }
set *PropertyName* (*PropertySetParameterList*) { *FunctionBody* }

PropertyName : See 11.1.5
IdentifierName
StringLiteral
NumericLiteral

PropertySetParameterList : See 11.1.5
Identifier

| | |
|---|-----------------|
| <i>MemberExpression</i> : | <i>See 11.2</i> |
| <i>PrimaryExpression</i> | |
| <i>FunctionExpression</i> | |
| <i>MemberExpression</i> [<i>Expression</i>] | |
| <i>MemberExpression</i> . <i>IdentifierName</i> | |
| new <i>MemberExpression</i> <i>Arguments</i> | |
| | |
| <i>NewExpression</i> : | <i>See 11.2</i> |
| <i>MemberExpression</i> | |
| new <i>NewExpression</i> | |
| | |
| <i>CallExpression</i> : | <i>See 11.2</i> |
| <i>MemberExpression</i> <i>Arguments</i> | |
| <i>CallExpression</i> <i>Arguments</i> | |
| <i>CallExpression</i> [<i>Expression</i>] | |
| <i>CallExpression</i> . <i>IdentifierName</i> | |
| | |
| <i>Arguments</i> : | <i>See 11.2</i> |
| () | |
| (<i>ArgumentList</i>) | |
| | |
| <i>ArgumentList</i> : | <i>See 11.2</i> |
| <i>AssignmentExpression</i> | |
| <i>ArgumentList</i> , <i>AssignmentExpression</i> | |
| | |
| <i>LeftHandSideExpression</i> : | <i>See 11.2</i> |
| <i>NewExpression</i> | |
| <i>CallExpression</i> | |
| | |
| <i>PostfixExpression</i> : | <i>See 11.3</i> |
| <i>LeftHandSideExpression</i> | |
| <i>LeftHandSideExpression</i> [no <i>LineTerminator</i> here] ++ | |
| <i>LeftHandSideExpression</i> [no <i>LineTerminator</i> here] -- | |
| | |
| <i>UnaryExpression</i> : | <i>See 11.4</i> |
| <i>PostfixExpression</i> | |
| delete <i>UnaryExpression</i> | |
| void <i>UnaryExpression</i> | |
| typeof <i>UnaryExpression</i> | |
| ++ <i>UnaryExpression</i> | |
| -- <i>UnaryExpression</i> | |
| + <i>UnaryExpression</i> | |
| - <i>UnaryExpression</i> | |
| ~ <i>UnaryExpression</i> | |
| ! <i>UnaryExpression</i> | |

MultiplicativeExpression : *See 11.5*
UnaryExpression
MultiplicativeExpression * *UnaryExpression*
MultiplicativeExpression / *UnaryExpression*
MultiplicativeExpression % *UnaryExpression*

AdditiveExpression : *See 11.6*
MultiplicativeExpression
AdditiveExpression + *MultiplicativeExpression*
AdditiveExpression - *MultiplicativeExpression*

ShiftExpression : *See 11.7*
AdditiveExpression
ShiftExpression << *AdditiveExpression*
ShiftExpression >> *AdditiveExpression*
ShiftExpression >>> *AdditiveExpression*

RelationalExpression : *See 11.8*
ShiftExpression
RelationalExpression < *ShiftExpression*
RelationalExpression > *ShiftExpression*
RelationalExpression <= *ShiftExpression*
RelationalExpression >= *ShiftExpression*
RelationalExpression instanceof *ShiftExpression*
RelationalExpression in *ShiftExpression*

RelationalExpressionNoIn : *See 11.8*
ShiftExpression
RelationalExpressionNoIn < *ShiftExpression*
RelationalExpressionNoIn > *ShiftExpression*
RelationalExpressionNoIn <= *ShiftExpression*
RelationalExpressionNoIn >= *ShiftExpression*
RelationalExpressionNoIn instanceof *ShiftExpression*

EqualityExpression : *See 11.9*
RelationalExpression
EqualityExpression == *RelationalExpression*
EqualityExpression != *RelationalExpression*
EqualityExpression === *RelationalExpression*
EqualityExpression !== *RelationalExpression*

EqualityExpressionNoIn : *See 11.9*
RelationalExpressionNoIn
EqualityExpressionNoIn == *RelationalExpressionNoIn*
EqualityExpressionNoIn != *RelationalExpressionNoIn*
EqualityExpressionNoIn === *RelationalExpressionNoIn*
EqualityExpressionNoIn !== *RelationalExpressionNoIn*

| | |
|--|------------------|
| <i>BitwiseANDExpression :</i> <i>EqualityExpression</i> <i>BitwiseANDExpression & EqualityExpression</i> | <i>See 11.10</i> |
| <i>BitwiseANDExpressionNoIn :</i> <i>EqualityExpressionNoIn</i> <i>BitwiseANDExpressionNoIn & EqualityExpressionNoIn</i> | <i>See 11.10</i> |
| <i>BitwiseXORExpression :</i> <i>BitwiseANDExpression</i> <i>BitwiseXORExpression ^ BitwiseANDExpression</i> | <i>See 11.10</i> |
| <i>BitwiseXORExpressionNoIn :</i> <i>BitwiseANDExpressionNoIn</i> <i>BitwiseXORExpressionNoIn ^ BitwiseANDExpressionNoIn</i> | <i>See 11.10</i> |
| <i>BitwiseORExpression :</i> <i>BitwiseXORExpression</i> <i>BitwiseORExpression BitwiseXORExpression</i> | <i>See 11.10</i> |
| <i>BitwiseORExpressionNoIn :</i> <i>BitwiseXORExpressionNoIn</i> <i>BitwiseORExpressionNoIn BitwiseXORExpressionNoIn</i> | <i>See 11.10</i> |
| <i>LogicalANDExpression :</i> <i>BitwiseORExpression</i> <i>LogicalANDExpression && BitwiseORExpression</i> | <i>See 11.11</i> |
| <i>LogicalANDExpressionNoIn :</i> <i>BitwiseORExpressionNoIn</i> <i>LogicalANDExpressionNoIn && BitwiseORExpressionNoIn</i> | <i>See 11.11</i> |
| <i>LogicalORExpression :</i> <i>LogicalANDExpression</i> <i>LogicalORExpression LogicalANDExpression</i> | <i>See 11.11</i> |
| <i>LogicalORExpressionNoIn :</i> <i>LogicalANDExpressionNoIn</i> <i>LogicalORExpressionNoIn LogicalANDExpressionNoIn</i> | <i>See 11.11</i> |
| <i>ConditionalExpression :</i> <i>LogicalORExpression</i> <i>LogicalORExpression ? AssignmentExpression : AssignmentExpression</i> | <i>See 11.12</i> |
| <i>ConditionalExpressionNoIn :</i> <i>LogicalORExpressionNoIn</i> <i>LogicalORExpressionNoIn ? AssignmentExpressionNoIn : AssignmentExpressionNoIn</i> | <i>See 11.12</i> |

AssignmentExpression : *See 11.13*
ConditionalExpression
LeftHandSideExpression *AssignmentOperator* *AssignmentExpression*

AssignmentExpressionNoIn : *See 11.13*
ConditionalExpressionNoIn
LeftHandSideExpression *AssignmentOperator* *AssignmentExpressionNoIn*

AssignmentOperator : **one of** *See 11.13*
= ***=** **/=** **%=** **+=** **-=** **<<=** **>>=** **>>>=** **&=** **^=** **|=**

Expression : *See 11.14*
AssignmentExpression
Expression , *AssignmentExpression*

ExpressionNoIn : *See 11.14*
AssignmentExpressionNoIn
ExpressionNoIn , *AssignmentExpressionNoIn*

A.4 Statements

Statement : *See clause 12*
Block
VariableStatement
EmptyStatement
ExpressionStatement
IfStatement
IterationStatement
ContinueStatement
BreakStatement
ReturnStatement
WithStatement
LabelledStatement
SwitchStatement
ThrowStatement
TryStatement
DebuggerStatement

Block : *See 12.1*
{ *StatementList*_{opt} **}**

StatementList : *See 12.1*
Statement
StatementList *Statement*

VariableStatement : *See 12.2*
var *VariableDeclarationList* ;

VariableDeclarationList : *See 12.2*
VariableDeclaration
VariableDeclarationList , *VariableDeclaration*

| | |
|---|------------------|
| <i>VariableDeclarationListNoIn</i> : | <i>See 12.2</i> |
| <i>VariableDeclarationNoIn</i> <i>VariableDeclarationListNoIn</i> , <i>VariableDeclarationNoIn</i> | |
| <i>VariableDeclaration</i> : | <i>See 12.2</i> |
| <i>Identifier Initialiser</i> _{opt} | |
| <i>VariableDeclarationNoIn</i> : | <i>See 12.2</i> |
| <i>Identifier InitialiserNoIn</i> _{opt} | |
| <i>Initialiser</i> : | <i>See 12.2</i> |
| = <i>AssignmentExpression</i> | |
| <i>InitialiserNoIn</i> : | <i>See 12.2</i> |
| = <i>AssignmentExpressionNoIn</i> | |
| <i>EmptyStatement</i> : | <i>See 12.3</i> |
| ; | |
| <i>ExpressionStatement</i> : | <i>See 12.4</i> |
| [lookahead ∉ { { , function }] <i>Expression</i> ; | |
| <i>IfStatement</i> : | <i>See 12.5</i> |
| if (<i>Expression</i>) <i>Statement</i> else <i>Statement</i> if (<i>Expression</i>) <i>Statement</i> | |
| <i>IterationStatement</i> : | <i>See 12.6</i> |
| do <i>Statement</i> while (<i>Expression</i>) ; while (<i>Expression</i>) <i>Statement</i> for (<i>ExpressionNoIn</i> _{opt} ; <i>Expression</i> _{opt} ; <i>Expression</i> _{opt}) <i>Statement</i> for (var <i>VariableDeclarationListNoIn</i> ; <i>Expression</i> _{opt} ; <i>Expression</i> _{opt}) <i>Statement</i> for (<i>LeftHandSideExpression</i> in <i>Expression</i>) <i>Statement</i> for (var <i>VariableDeclarationNoIn</i> in <i>Expression</i>) <i>Statement</i> | |
| <i>ContinueStatement</i> : | <i>See 12.7</i> |
| continue [no <i>LineTerminator</i> here] <i>Identifier</i> _{opt} ; | |
| <i>BreakStatement</i> : | <i>See 12.8</i> |
| break [no <i>LineTerminator</i> here] <i>Identifier</i> _{opt} ; | |
| <i>ReturnStatement</i> : | <i>See 12.9</i> |
| return [no <i>LineTerminator</i> here] <i>Expression</i> _{opt} ; | |
| <i>WithStatement</i> : | <i>See 12.10</i> |
| with (<i>Expression</i>) <i>Statement</i> | |

SwitchStatement : *See 12.11*
switch (*Expression*) *CaseBlock*

CaseBlock : *See 12.11*
{ *CaseClauses_{opt}* }
{ *CaseClauses_{opt} DefaultClause CaseClauses_{opt}* }

CaseClauses : *See 12.11*
CaseClause
CaseClauses CaseClause

CaseClause : *See 12.11*
case *Expression* : *StatementList_{opt}*

DefaultClause : *See 12.11*
default : *StatementList_{opt}*

LabelledStatement : *See 12.12*
Identifier : *Statement*

ThrowStatement : *See 12.13*
throw [no *LineTerminator* here] *Expression* ;

TryStatement : *See 12.14*
try *Block Catch*
try *Block Finally*
try *Block Catch Finally*

Catch : *See 12.14*
catch (*Identifier*) *Block*

Finally : *See 12.14*
finally *Block*

DebuggerStatement : *See 12.15*
debugger ;

A.5 Functions and Programs

FunctionDeclaration : *See clause 13*
function *Identifier* (*FormalParameterList_{opt}*) { *FunctionBody* }

FunctionExpression : *See clause 13*
function *Identifier_{opt}* (*FormalParameterList_{opt}*) { *FunctionBody* }

FormalParameterList : *See clause 13*
Identifier
FormalParameterList , *Identifier*

FunctionBody : *SourceElements*_{opt} See clause 13

Program : *SourceElements*_{opt} See clause 14

SourceElements : *SourceElement*
SourceElements SourceElement See clause 14

SourceElement : *Statement*
FunctionDeclaration See clause 14

UseStrictDirective : [no *LineTerminator* here] **use** [no *LineTerminator* here] **strict** [no *LineTerminator* here] *useExtension*_{opt} See clause 14.1

useExtension : *ArbitraryInputElements*_{opt} See clause 14.1

ArbitraryInputElements : [any sequence of lexical input elements that does not include any *LineTerminator* elements] See clause 14.1

A.6 Universal Resource Identifier Character Classes

uri ::: *uriCharacters*_{opt} See 15.1.3

uriCharacters ::: *uriCharacter* *uriCharacters*_{opt} See 15.1.3

uriCharacter ::: *uriReserved*
uriUnescaped
uriEscaped See 15.1.3

uriReserved ::: one of ; / ? : @ & = + \$, See 15.1.3

uriUnescaped ::: *uriAlpha*
DecimalDigit
uriMark See 15.1.3

uriEscaped ::: % *HexDigit* *HexDigit* See 15.1.3

uriAlpha ::: one of a b c d e f g h i j k l m n o p q r s t u v w x y z
A B C D E F G H I J K L M N O P Q R S T U V W X Y Z See 15.1.3

uriMark ::: one of See 15.1.3
- _ . ! ~ * \ ()

A.7 Regular Expressions

Pattern :: See 15.10.1
Disjunction

Disjunction :: See 15.10.1
Alternative
Alternative | *Disjunction*

Alternative :: See 15.10.1
[empty]
Alternative Term

Term :: See 15.10.1
Assertion
Atom
Atom Quantifier

Assertion :: See 15.10.1
^
\$
\ b
\ B
(? = *Disjunction*)
(? ! *Disjunction*)

Quantifier :: See 15.10.1
QuantifierPrefix
QuantifierPrefix ?

QuantifierPrefix :: See 15.10.1
*
+
?
{ *DecimalDigits* }
{ *DecimalDigits* , }
{ *DecimalDigits* , *DecimalDigits* }

Atom :: See 15.10.1
PatternCharacter
.
\ *AtomEscape*
CharacterClass
(*Disjunction*)
(? : *Disjunction*)

PatternCharacter :: *SourceCharacter* but not any of: See 15.10.1
^ \$ \ . * + ? () [] { } |

AtomEscape :: *DecimalEscape*
CharacterEscape
CharacterClassEscape *See 15.10.1*

CharacterEscape :: *ControlEscape*
c *ControlLetter*
HexEscapeSequence
UnicodeEscapeSequence
IdentityEscape *See 15.10.1*

ControlEscape :: **one of**
f n r t v *See 15.10.1*

ControlLetter :: **one of** *See 15.10.1*
a b c d e f g h i j k l m n o p q r s t u v w x y z
A B C D E F G H I J K L M N O P Q R S T U V W X Y Z

IdentityEscape :: *SourceCharacter* **but not** *IdentifierPart*
<ZWJ>
<ZWNJ> *See 15.10.1*

DecimalEscape :: *DecimalIntegerLiteral* [lookahead \notin *DecimalDigit*] *See 15.10.1*

CharacterClassEscape :: **one of**
d D s S w W *See 15.10.1*

CharacterClass ::
[[lookahead \notin {^}] *ClassRanges*]
[^ *ClassRanges*] *See 15.10.1*

ClassRanges ::
[empty]
NonemptyClassRanges *See 15.10.1*

NonemptyClassRanges :: *ClassAtom*
ClassAtom *NonemptyClassRangesNoDash*
ClassAtom - *ClassAtom* *ClassRanges* *See 15.10.1*

NonemptyClassRangesNoDash :: *ClassAtom*
ClassAtomNoDash *NonemptyClassRangesNoDash*
ClassAtomNoDash - *ClassAtom* *ClassRanges* *See 15.10.1*

ClassAtom ::
-
ClassAtomNoDash *See 15.10.1*

ClassAtomNoDash ::
SourceCharacter **but not one of** \] -
\
ClassEscape *See 15.10.1*

ClassEscape ::
DecimalEscape
b
CharacterEscape
CharacterClassEscape *See 15.10.1*

A.8 JSON

A.8.1 JSON Lexical Grammar

JSONWhiteSpace :: *See 15.12.1.1*
<*TAB*>
<*CR*>
<*LF*>
<*SP*>

JSONString :: *See 15.12.1.1*
"JSONStringCharacter_{opt}"

JSONStringCharacter :: *See 15.12.1.1*
JSONStringCharacter *JSONStringCharacter*_{opt}

JSONStringCharacter :: *See 15.12.1.1*
JSONSourceCharacter **but not double-quote "** **or backslash ** **or U+0000 thru U+001F**
\
JSONEscapeSequence

JSONEscapeSequence :: *See 15.12.1.1*
JSONEscapeCharacter
UnicodeEscapeSequence

JSONEscapeCharacter :: **one of** *See 15.12.1.1*
" / \ **b f n r t**

JSONNumber :: *See 15.12.1.1*
-_{opt} *DecimalIntegerLiteral* *JSONFraction*_{opt} *ExponentPart*_{opt}

JSONFraction :: *See 15.12.1.1*
. *DecimalDigits*

JSONNullLiteral :: *See 15.12.1.1*
NullLiteral

JSONBooleanLiteral :: *See 15.12.1.1*
BooleanLiteral

A.8.2 JSON Syntactic Grammar

JSONText : *See 15.12.1.2*
JSONValue

JSONValue : *See 15.12.1.2*
JSONNullLiteral
JSONBooleanLiteral
JSONObject
JSONArray

JSONString
JSONNumber

JSONObject : *See 15.12.1.2*
{ }
{ JSONMemberList }

JSONMember : *See 15.12.1.2*
JSONString : JSONValue

JSONMemberList : *See 15.12.1.2*
JSONMember
JSONMemberList , JSONMember

JSONArray : *See 15.12.1.2*
[]
[JSONElementList]

JSONElementList : *See 15.12.1.2*
JSONValue
JSONElementList , JSONValue

DRAFT

Annex B (informative)

Compatibility

B.1 Additional Syntax

Past editions of ECMAScript have included additional syntax and semantics for specifying octal literals and octal escape sequences. These have been removed from this edition of ECMAScript. This non-normative annex presents uniform syntax and semantics for octal literals and octal escape sequences for compatibility with some older ECMAScript programs.

B.1.1 Numeric Literals

The syntax and semantics of 7.8.3 can be extended as follows except that this extension is not allowed for strict mode code:

Syntax

NumericLiteral ::
DecimalLiteral
HexIntegerLiteral
OctalIntegerLiteral

OctalIntegerLiteral ::
0 *OctalDigit*
OctalIntegerLiteral *OctalDigit*

OctalDigit :: **one of**
0 1 2 3 4 5 6 7

Semantics

- The MV of *NumericLiteral* :: *OctalIntegerLiteral* is the MV of *OctalIntegerLiteral*.
- The MV of *OctalDigit* :: **0** is 0.
- The MV of *OctalDigit* :: **1** is 1.
- The MV of *OctalDigit* :: **2** is 2.
- The MV of *OctalDigit* :: **3** is 3.
- The MV of *OctalDigit* :: **4** is 4.
- The MV of *OctalDigit* :: **5** is 5.
- The MV of *OctalDigit* :: **6** is 6.
- The MV of *OctalDigit* :: **7** is 7.
- The MV of *OctalIntegerLiteral* :: **0** *OctalDigit* is the MV of *OctalDigit*.
- The MV of *OctalIntegerLiteral* :: *OctalIntegerLiteral* *OctalDigit* is (the MV of *OctalIntegerLiteral* times 8) plus the MV of *OctalDigit*.

B.1.2 String Literals

The syntax and semantics of 7.8.4 can be extended as follows except that this extension is not allowed for strict mode code:

Syntax

EscapeSequence ::

CharacterEscapeSequence
OctalEscapeSequence
HexEscapeSequence
UnicodeEscapeSequence

OctalEscapeSequence ::

OctalDigit [lookahead \notin *DecimalDigit*]
ZeroToThree OctalDigit [lookahead \notin *DecimalDigit*]
FourToSeven OctalDigit
ZeroToThree OctalDigit OctalDigit

ZeroToThree :: one of

0 1 2 3

FourToSeven :: one of

4 5 6 7

Semantics

- The CV of *EscapeSequence* :: *OctalEscapeSequence* is the CV of the *OctalEscapeSequence*.
- The CV of *OctalEscapeSequence* :: *OctalDigit* [lookahead \notin *DecimalDigit*] is the character whose code unit value is the MV of the *OctalDigit*.
- The CV of *OctalEscapeSequence* :: *ZeroToThree OctalDigit* [lookahead \notin *DecimalDigit*] is the character whose code unit value is (8 times the MV of the *ZeroToThree*) plus the MV of the *OctalDigit*.
- The CV of *OctalEscapeSequence* :: *FourToSeven OctalDigit* is the character whose code unit value is (8 times the MV of the *FourToSeven*) plus the MV of the *OctalDigit*.
- The CV of *OctalEscapeSequence* :: *ZeroToThree OctalDigit OctalDigit* is the character whose code unit value is (64 (that is, 8^2) times the MV of the *ZeroToThree*) plus (8 times the MV of the first *OctalDigit*) plus the MV of the second *OctalDigit*.
- The MV of *ZeroToThree* :: 0 is 0.
- The MV of *ZeroToThree* :: 1 is 1.
- The MV of *ZeroToThree* :: 2 is 2.
- The MV of *ZeroToThree* :: 3 is 3.
- The MV of *FourToSeven* :: 4 is 4.
- The MV of *FourToSeven* :: 5 is 5.
- The MV of *FourToSeven* :: 6 is 6.
- The MV of *FourToSeven* :: 7 is 7.

B.2 Additional Properties

Some implementations of ECMAScript have included additional properties for some of the standard native objects. This non-normative annex suggests uniform semantics for such properties without making the properties or their semantics part of this standard.

B.2.1 **escape** (string)

The **escape** function is a property of the global object. It computes a new version of a string value in which certain characters have been replaced by a hexadecimal escape sequence.

For those characters being replaced whose code unit value is **0xFF** or less, a two-digit escape sequence of the form **%xx** is used. For those characters being replaced whose code unit value is greater than **0xFF**, a four-digit escape sequence of the form **%uxxxx** is used

When the **escape** function is called with one argument *string*, the following steps are taken:

1. Call **ToString**(*string*).

2. Compute the number of characters in Result(1).
3. Let *R* be the empty string.
4. Let *k* be 0.
5. If *k* equals Result(2), return *R*.
6. Get the character (represented as a 16-bit unsigned integer) at position *k* within Result(1).
7. If Result(6) is one of the 69 nonblank characters
`"ABCDEFGHIJKLMNOPQRSTUVWXYZabcdefghijklmnopqrstuvwxyz0123456789@*_+-. /"`
then go to step 13.
8. If Result(6), is less than 256, go to step 11.
9. Let *S* be a string containing six characters `"%uvwxyz"` where *wxyz* are four hexadecimal digits encoding the value of Result(6).
10. Go to step 14.
11. Let *S* be a string containing three characters `"%xy"` where *xy* are two hexadecimal digits encoding the value of Result(6).
12. Go to step 14.
13. Let *S* be a string containing the single character Result(6).
14. Let *R* be a new string value computed by concatenating the previous value of *R* and *S*.
15. Increase *k* by 1.
16. Go to step 5.

NOTE

The encoding is partly based on the encoding described in RFC1738, but the entire encoding specified in this standard is described above without regard to the contents of RFC1738.

B.2.2 unescape (string)

The **unescape** function is a property of the global object. It computes a new version of a string value in which each escape sequence of the sort that might be introduced by the **escape** function is replaced with the character that it represents.

When the **unescape** function is called with one argument *string*, the following steps are taken:

1. Call ToString(*string*).
2. Compute the number of characters in Result(1).
3. Let *R* be the empty string.
4. Let *k* be 0.
5. If *k* equals Result(2), return *R*.
6. Let *c* be the character at position *k* within Result(1).
7. If *c* is not %, go to step 18.
8. If *k* is greater than Result(2)-6, go to step 14.
9. If the character at position *k*+1 within Result(1) is not **u**, go to step 14.
10. If the four characters at positions *k*+2, *k*+3, *k*+4, and *k*+5 within Result(1) are not all hexadecimal digits, go to step 14.
11. Let *c* be the character whose code unit value is the integer represented by the four hexadecimal digits at positions *k*+2, *k*+3, *k*+4, and *k*+5 within Result(1).
12. Increase *k* by 5.
13. Go to step 18.
14. If *k* is greater than Result(2)-3, go to step 18.
15. If the two characters at positions *k*+1 and *k*+2 within Result(1) are not both hexadecimal digits, go to step 18.
16. Let *c* be the character whose code unit value is the integer represented by two zeroes plus the two hexadecimal digits at positions *k*+1 and *k*+2 within Result(1).
17. Increase *k* by 2.
18. Let *R* be a new string value computed by concatenating the previous value of *R* and *c*.
19. Increase *k* by 1.
20. Go to step 5.

B.2.3 String.prototype.substr (start, length)

The **substr** method takes two arguments, *start* and *length*, and returns a substring of the result of converting this object to a string, starting from character position *start* and running for *length* characters (or through the end of the string if *length* is **undefined**). If *start* is negative, it is treated as (*sourceLength*+*start*) where *sourceLength* is the length of the string. The result is a string value, not a String object. The following steps are taken:

1. Call ToString, giving it the **this** value as its argument.
2. Call ToInteger(*start*).
3. If *length* is **undefined**, use $+\infty$; otherwise call ToInteger(*length*).
4. Compute the number of characters in Result(1).
5. If Result(2) is positive or zero, use Result(2); else use $\max(\text{Result}(4)+\text{Result}(2), 0)$.
6. Compute $\min(\max(\text{Result}(3), 0), \text{Result}(4)-\text{Result}(5))$.
7. If $\text{Result}(6) \leq 0$, return the empty string "".
8. Return a string containing Result(6) consecutive characters from Result(1) beginning with the character at position Result(5).

The **length** property of the **substr** method is 2.

NOTE

The **substr** function is intentionally generic; it does not require that its **this** value be a String object. Therefore it can be transferred to other kinds of objects for use as a method.

B.2.4 Date.prototype.getYear ()

NOTE

The **getFullYear** method is preferred for nearly all purposes, because it avoids the "year 2000 problem."

When the **getYear** method is called with no arguments, the following steps are taken:

1. Let *t* be this time value.
2. If *t* is NaN, return NaN.
3. Return YearFromTime(LocalTime(*t*)) – 1900.

B.2.5 Date.prototype.setYear (year)

NOTE

The **setFullYear** method is preferred for nearly all purposes, because it avoids the "year 2000 problem."

When the **setYear** method is called with one argument *year*, the following steps are taken:

1. Let *t* be the result of LocalTime(this time value); but if this time value is NaN, let *t* be +0.
2. Call ToNumber(*year*).
3. If Result(2) is NaN, set the [[PrimitiveValue]] internal property of the **this** value to NaN and return NaN.
4. If Result(2) is not NaN and $0 \leq \text{ToInteger}(\text{Result}(2)) \leq 99$ then Result(4) is $\text{ToInteger}(\text{Result}(2)) + 1900$. Otherwise, Result(4) is Result(2).
5. Compute MakeDay(Result(4), MonthFromTime(*t*), DateFromTime(*t*)).
6. Compute UTC(MakeDate(Result(5), TimeWithinDay(*t*))).
7. Set the [[PrimitiveValue]] internal property of the **this** value to TimeClip(Result(6)).
8. Return the value of the [[PrimitiveValue]] internal property of the **this** value.

B.2.6 Date.prototype.toGMTString ()

NOTE

The property **toUTCString** is preferred. The **toGMTString** property is provided principally for compatibility with old code. It is recommended that the **toUTCString** property be used in new ECMAScript code.

The Function object that is the initial value of `Date.prototype.toGMTString` is the same Function object that is the initial value of `Date.prototype.toUTCString`.

DRAFT

Annex C

(informative)

The Strict Mode of ECMAScript

The strict mode restriction and exceptions

- A conforming implementation, when processing strict mode code, may not extend the syntax of *NumericLiteral* (7.8.3) to include *OctalIntegerLiteral* as described in B.1.1.
- Assignment to an undeclared identifier or otherwise unresolvable reference does not create a property in the global object. When a simple assignment occurs within strict mode code, its *LeftHandSide* must not evaluate to an unresolvable Reference. If it does a **ReferenceError** exception is thrown (8.7.2). The *LeftHandSide* also may not be a reference to a data property with the attribute value `{[[Writable]]:false}`, to an accessor property with the attribute value `{[[Put]]:undefined}`, nor to a non-existent property of an object whose `[[Extensible]]` internal property has the value **false**. In these cases a **TypeError** exception is thrown (11.13.1).
- The identifier **eval** may not appear as the *LeftHandSideExpression* of an Assignment operator (11.13) or of a *PostfixExpression* (11.3) or as the *UnaryExpression* operated upon by a Prefix Increment (11.4.4) or a Prefix Decrement (11.4.5) operator.
- Arguments objects for strict mode functions define non-configurable accessor properties named "**caller**" and "**callee**" which throw a **TypeError** exception on access (10.6).
- For strict mode functions, if an arguments object is created the binding of the local identifier **arguments** to the arguments object is immutable and hence may not be the target of an assignment expression. (10.5).
- It is a syntax error if strict mode code contains an *ObjectLiteral* with more than one definition of any data property (11.1.5).
- Strict mode eval code cannot instantiate variables or functions in the variable environment of the caller to eval. Instead, a new variable environment is created and that environment is used for declaration binding instantiation for the eval code (10.4.2).
- If **this** is evaluated within strict mode code, then the **this** value is not coerced to an object. A **this** value of **null** or **undefined** is not converted to the global object and primitive values are not converted to wrapper objects. In particular, the **this** value passed via a function call (including calls made using **Function.prototype.apply** and **Function.prototype.call**) do not coerce the passed **this** value to an object (10.4.3, 11.1.1, 15.3.4.3, 15.3.4.4).
- When a **delete** operator occurs within strict mode code, a **SyntaxError** is thrown if its *UnaryExpression* is a direct reference to a variable, function argument, or function name (11.4.1).
- When a **delete** operator occurs within strict mode code, a **TypeError** is thrown if the property to be deleted has the attribute `{ [[Configurable]]:false }` (11.4.1).
- It is a **SyntaxError** if a *VariableDeclaration* or *VariableDeclarationNoIn* occurs within strict code and its *Identifier* is **eval** or **arguments** (12.2.1).
- Strict mode code may not include a *WithStatement*. The occurrence of a *WithStatement* in such a context is a **SyntaxError** (12.10).
- It is a **SyntaxError** if a *TryStatement* with a *Catch* occurs within strict code and the *Identifier* of the *Catch* production is **eval** or **arguments** (12.14.1).
- It is a **SyntaxError** if the identifier **eval** or **arguments** appears within a *FormalParameterList* of a strict mode *FunctionDeclaration* or *FunctionExpression* (13.1).
- A strict mode function may not have two or more formal parameters that have the same name. An attempt to create such a function using a *FunctionDeclaration*, *FunctionExpression*, or Function constructor is a **SyntaxError** (13.1, 15.3.2).
- An implementation may not associate special meanings within strict mode functions to properties named **caller** or **arguments** of function instances. ECMAScript code may not create or modify properties with these names on function objects that correspond to strict mode functions (13.2).
- It is a **SyntaxError** to use within strict mode code the identifiers **eval** or **arguments** as the *Identifier* of a *FunctionDeclaration* or *FunctionExpression* or as a formal parameter name (13.1). Attempting to dynamically define such a strict mode function using the Function constructor (15.3.2) will throw a **SyntaxError** exception.

Annex D (Informative)

Correction and Clarifications in the 5th Edition with Possible Compatibility Impact

Throughout: In the Edition 3 specification the meaning of phrases such as “as if by the expression **new Array()**” are subject to misinterpretation. In the Edition 5 specification text for all internal references and invocations of standard built-in objects and methods has been clarified by making it implicit that the intent is that the actual built-in object is to be used rather than the current dynamic value of the correspondingly named property.

11.8.2, 11.8.3, 11.8.5 ECMAScript generally uses a left to right evaluation order, however the Edition 3 specification language for the `>` and `<=` operators resulted in a partial right to left order. The specification has been corrected for these operators such that it now specifies a full left to right evaluation order. However, this change of order is potentially observable if user-defined `valueOf` or `toString` methods with side-effects are invoked during the evaluation process.

11.1.4 Edition 5 clarifies the fact that a trailing comma at the end of an *Array Initialiser* does not add to the length of the array. This is not a semantic change from Edition 3 but some implementations may have previously misinterpreted this.

11.2.3 Edition 5 reverses the order of steps 2 and 3 of the algorithm. The original order as specified in Editions 1 through 3 was incorrectly specified such that side-effects of evaluating *Arguments* could affect the result of evaluating *MemberExpression*.

12.4 In Edition 3, an object is created, as if by `new Object()`, to serve as the scope for resolving the name of the exception parameter passed to a `catch` clause of a `try` statement. If the actual exception object is a function and it is called from within the `catch` clause, the scope object will be passed as the `this` value of the call. The body of the function can then define new properties on its `this` value and those property names become visible identifiers bindings within the scope of the `catch` clause after the function returns. In Edition 5, when an exception parameter is called as a function, `undefined` is passed as the `this` value.

13. In Edition 3, the algorithm for the production *FunctionExpression* with an *Identifier* adds an object created as if by `new Object()` to the scope chain to serve as a scope for looking up the name of the function. The identifier resolution rules (10.1.4 in Edition 3) when applied to such an object will, if necessary, follow the object’s prototype chain when attempting to resolve an identifier. This means all the properties of `Object.prototype` are visible as identifiers within that scope. In practice most implementations of Edition 3 have not implemented this semantics. Edition 5 changes the specified semantics by using a Declarative Environment Record to bind the name of the function.

14. In Edition 3, the algorithm for the production *SourceElements* : *SourceElements SourceElement* did not correctly propagate statement result values in the same manner as *Block*. This could result in the `eval` function producing an incorrect result when evaluating a *Program* text. In practice most implementations of Edition 3 have implemented the correct propagation rather than what was specified in Edition 3.

15.10.6 `RegExp.prototype` is now a `RegExp` object rather than an instance of `Object`. The value of its `[[Class]]` internal property which is observable using `Object.prototype.toString` is now “`RegExp`” rather than “`Object`”.

Annex E

(Informative)

Additions and Changes in Edition 5 which Introduce Incompatibilities with Edition 3.

Section 7.1: Unicode format control characters are no longer stripped from ECMAScript source text before processing. In Edition 5, if such a character appears in a *StringLiteral* or *RegularExpressionLiteral* the character will be incorporated into the literal where in Edition 3 the character would not be incorporated into the literal.

Section 7.2: Unicode character <BOM> is now treated as whitespace and its presence in the middle of what appears to be an identifier could result in a syntax error which would not have occurred in Edition 3

Section 7.3: Line terminator characters that are preceded by an escape sequence are now allowed within a string literal token. In Edition 3 a syntax error would have been produced.

Section 7.8.5: Regular expression literals now return a unique object each time the literal is evaluated. This change is detectable by any programs that test the object identity of such literal values or that are sensitive to the shared side effects.

Section 7.8.5: Edition 5 requires early reporting of any possible RegExp constructor errors that would be produced when converting a *RegularExpressionLiteral* to a RegExp object. Prior to Edition 5 implementations were permitted to defer the reporting of such errors until the actual execution time creation of the object.

Section 7.8.5: In Edition 5 unescaped “/” characters may appear as a *CharacterClass* in a regular expression literal. In Edition 3 such a character would have been interpreted as the final character of the literal.

Section 10.4.2: In Edition 5, indirect calls to the **eval** function use the global environment as both the variable environment and lexical environment for the eval code. In Edition 3, the variable and lexical environments of the caller of an indirect **eval** was used as the environments for the eval code.

Section 15.4.4: In Edition 5 all methods of **Array.prototype** are intentionally generic. In Edition 3 **toString** and **toLocaleString** were not generic and would throw a **TypeError** exception if applied to objects that were not instances of Array.

Section 10.6: In Edition 5 the array indexed properties of argument objects that correspond to actual formal parameters are enumerable. In Edition 3, such properties were not enumerable.

Section 10.6: In Edition 5, the `[[Prototype]]` of an arguments object is **Array.prototype**. In Edition 3 it was **Object.prototype**. However, Edition 5 argument objects also have own properties that over-ride **Array.prototype.constructor**, **Array.prototype.toString**, and **Array.prototype.toLocaleString** with the standard built-in **Object.prototype** versions of these properties. Using **Object.prototype.isPrototypeOf** to test the prototype of an arguments object or any access to properties of an arguments object that are inherited from **Array.prototype** other than **constructor**, **toString** and **toLocaleString** may produce different results.

Section 10.6: In Edition 5 the value of the `[[Class]]` internal property of an arguments object is "**Arguments**". In Edition 3, it was "**Object**". This is observable if **toString** is called as a method of an arguments object.

Section 12.6.4: for-in statements no longer throw a **TypeError** if the **in** expression evaluates to **null** or **undefined**. Instead, the statement behaves as if the value of the expression was an object with no enumerable properties.

Section 15: In Edition 5, the following new properties are defined on built-in objects that exist in Edition 3: **Object.getPrototypeOf**, **Object.getOwnPropertyDescriptor**, **Object.getOwnPropertyName**, **Object.create**, **Object.defineProperty**, **Object.defineProperties**, **Object.seal**, **Object.freeze**, **Object.preventExtensions**, **Object.isSealed**, **Object.isFrozen**, **Object.isExtensible**, **Object.keys**, **Function.prototype.bind**, **Array.prototype.indexOf**, **Array.prototype.lastIndexOf**, **Array.prototype.every**, **Array.prototype.some**,

Array.prototype.forEach, **Array.prototype.map**, **Array.prototype.filter**,
Array.prototype.reduce, **Array.prototype.reduceRight**, **String.prototype.trim**,
Date.now, **Date.prototype.toISOString**, **Date.prototype.toJSON**.

Section 15: Implementations are now required to ignore extra arguments to standard built-in methods unless otherwise explicitly specified. In Edition 3 the handling of extra arguments was unspecified and implementations were explicitly allowed to throw a **TypeError** exception.

Section 15.1.1: The value properties **NaN**, **Infinity**, and **undefined** of the Global Object have been changed to be read-only properties.

Section 15.1.2.1. Implementations are no longer permitted to restrict the use of **eval** in ways that are not a direct call. In addition, any invocation of **eval** that is not a direct call uses the global environment as its variable environment rather than the caller's variable environment.

Section 15.1.2.2: The specification of the function **parseInt** no longer allows implementations to treat strings beginning with a **0** character as octal values.

Sections 15.3.4.3, 15.3.4.4: In Edition 3 passing **undefined** or **null** as the first argument to **Function.prototype.apply** or **Function.prototype.call** causes the global object to be passed to the indirectly invoked target function as the **this** value. If the first argument is a primitive value the result of calling **ToObject** on the primitive value is passed as the **this** value. In Edition 5, these transformations are not performed and the actual first argument value is passed as the **this** value. This difference will normally be unobservable to existing ECMAScript Edition 3 code because a corresponding transformation takes place upon activation of the target function. However, depending upon the implementation, this difference may be observable by host object functions called using **apply** or **call**. In addition, invoking a standard built-in function in this manner with **null** or **undefined** passed as the **this** value will in many cases cause behaviour in Edition 5 implementations that differ from Edition 3 behaviour. In particular, in Edition 5 built-in functions that are specified to actually use the passed **this** value as an object typically throw a **TypeError** exception if passed **null** or **undefined** as the **this** value.

Section 15.9.4.2: **Date.parse** is now required to first attempt to parse its argument as an ISO format string. Programs that use this format but depended upon implementation specific behaviour (including failure) may behave differently.

Section 15.10.2.12: In Edition 5, **\s** now additionally matches <BOM>.

Section 15.10.4.1: In Edition 3, the exact form of the string value of the **source** property of an object created by the **RegExp** constructor is implementation defined. In Edition 5, the string must conform to certain specified requirements and hence may be different from that produced by an Edition 3 implementation.

Section 15.10.6.4: In Edition 3, the result of **RegExp.prototype.toString** need not be derived from the value of the **RegExp** object's **source** property. In Edition 5 the result must be derived from the **source** property in a specified manner and hence may be different from the result produced by an Edition 3 implementation.

Sections 15.11.2.1, 15.11.4.3: In Edition 5, if an initial value for the **message** property of an **Error** object is not specified via the **Error** constructor the initial value of the property is the empty string. In Edition 3, such an initial value is implementation defined.

Section 15.11.4.4: In Edition 3, the result of **Error.prototype.toString** is implementation defined. In Edition 5, the result is fully specified and hence may differ from some Edition 3 implementations.

Section 15.12: In Edition 5, the name **JSON** is defined in the global environment. In Edition 3, testing for the presence of that name will show it to be undefined unless it is defined by the program or implementation.

DRAFT

Free printed copies can be ordered from:

ECMA
114 Rue du Rhône
CH-1204 Geneva
Switzerland

Fax: +41 22 849.60.01
Interne.ch

Files of this Standard can be freely downloaded from our ECMA web site (www.ecma.ch). This site gives full information on ECMA, ECMA activities, ECMA Standards and Technical Reports.

DRAFT

ECMA

**114 Rue du Rhône
CH-1204 Geneva
Switzerland**

See inside cover page for obtaining further soft or hard copies.