

ECMA

Standardizing Information and Communication Systems

---

---

---

**Private Integrated Services  
Network (PISN) -  
Specification, Functional Model  
and Information Flows -  
Common Information  
Additional Network Feature**

---

---



ECMA

Standardizing Information and Communication Systems

---

---

---

**Private Integrated Services  
Network (PISN) -  
Specification, Functional Model  
and Information Flows -  
Common Information  
Additional Network Feature**

---

---

**(ANF-CMNSD)**



## **Brief History**

This Standard is one of a series of ECMA standards defining services and signalling protocols applicable to Private Integrated Services Networks. The series uses the ISDN concepts as developed by ITU-T (formerly CCITT) and is also within the framework of standards for open systems interconnection as defined by ISO. It has been produced under ETSI work item DE/ECMA-00070.

This Standard specifies the Common Information additional network feature.

The Standard is based upon the practical experience of ECMA member companies and the results of their active and continuous participation in the work of ISO/IEC JTC1, ITU-T, ETSI and other international and national standardization bodies. It represents a pragmatic and widely based consensus.

There is currently no equivalent feature specified by ITU-T or ETSI for public ISDNs.

This ECMA Standard is contributed to ISO/IEC JTC1 under the terms of the fast-track procedure for adoption as an ISO/IEC International Standard, and with the intention of subsequent endorsement by ETSI as an EN.

This Standard has been adopted by the ECMA General Assembly of December 1996.



## Table of contents

<b>1 Scope</b>	<b>1</b>
<b>2 Conformance</b>	<b>1</b>
<b>3 References (normative)</b>	<b>1</b>
<b>4 Definitions</b>	<b>1</b>
4.1 External definitions	1
4.2 Additional Network Feature	2
4.3 ANF-CMN User	2
4.4 Backward direction	2
4.5 Call, Basic Call	2
4.6 Common Information	2
4.7 Feature Identifier	2
4.8 Forward direction	2
4.9 Equipment Identity	2
4.10 Node Identity	2
4.11 Group Identity	2
4.12 Unit Identity	3
4.13 Party Category	3
<b>5 List of acronyms</b>	<b>3</b>
<b>6 ANF-CMN stage 1 specification</b>	<b>3</b>
6.1 Description	3
6.1.1 General description	3
6.1.2 Qualifications on Applicability to Telecommunication Services	3
6.2 Procedures	3
6.2.1 Provision/Withdrawal	3
6.2.2 Normal procedures	4
6.2.3 Exceptional procedures	4
6.3 Interactions with other Supplementary Services and ANFs	4
6.3.1 Calling Line Identification Presentation (CLIP)	4
6.3.2 Connected Line Identification Presentation (COLP)	4
6.3.3 Calling/Connected Line Identification Restriction (CLIR)	4
6.3.4 Calling Name Identification Presentation (CNIP)	4
6.3.5 Connected Name Identification Presentation (CONP)	4
6.3.6 Calling/Connected Name Identification Restriction (CNIR)	4
6.3.7 Call Forwarding Unconditional (CFU)	4
6.3.8 Call Forwarding Busy (CFB)	4
6.3.9 Call Forwarding No Reply (CFNR)	5
6.3.10 Call Deflection (CD)	5
6.3.11 Call Transfer (CT)	5

6.3.12 Completion of Calls to Busy Subscriber (CCBS)	5
6.3.13 Completion of Calls on No Reply (CCNR)	5
6.3.14 Call Intrusion (CI)	5
6.3.15 Call Offer (CO)	5
6.3.16 Do Not Disturb (DND)	5
6.3.17 Do Not Disturb Override (DNDO)	5
6.3.18 Call Interception (CINT)	5
6.3.19 Advice Of Charge (AOC)	5
6.3.20 Message Waiting Indication (MWI)	5
6.3.21 Path Replacement (PR)	5
6.3.22 Recall (RE)	5
6.3.23 Cordless Terminal Mobility, Outgoing call (CTMO)	5
6.3.24 Cordless Terminal Mobility, Incoming call (CTMI)	5
6.3.25 Cordless Terminal, Location Registration (CTLR)	6
6.3.26 Cordless Terminal, Authentication (CTAU)	6
6.3.27 Transit Counter (TC)	6
6.4 Interworking considerations	6
6.5 Overall SDL	6
<b>7 ANF-CMN stage 2 specification</b>	<b>8</b>
7.1 Functional Model	8
7.1.1 Functional Model Description	8
7.1.2 Description of Functional Entities	8
7.1.3 Relationship of Functional Model to Basic Call Functional Model	8
7.2 Information Flows	9
7.2.1 Definition of Information Flows	9
7.2.2 Relationship of Information Flows to Basic Call Information Flows	12
7.2.3 Information Flow Sequences	12
7.3 Functional entity actions	14
7.3.1 Functional entity actions of FE1	14
7.3.2 Functional entity actions of FE2	14
7.4 Functional entity behaviour	14
7.4.1 Behaviour of FE1	15
7.4.2 Behaviour of FE2	16
7.5 Allocation of Functional Entities to Physical Equipment	16
7.6 Interworking considerations	16



## 1 Scope

This Standard specifies the additional network feature Common Information (ANF-CMN), which is applicable to various basic services supported by Private Integrated Services Networks (PISN). Basic services are specified in ISO/IEC 11574.

ANF-CMN is an additional network feature which enables the exchange of Common Information between entities acting on behalf of the two ends of a connection through a PISN. This Common Information relates to the user or equipment at one end of a connection and includes one or more of the following: Feature Identifiers, Party Category, Equipment Identity. This information, when received by an entity, can be used for any purpose, e.g. as the basis for indications to the local user or to another network or in order to filter feature requests.

Additional network feature specifications are produced in three stages, according to the method described in ETS 300 387. This Standard contains the stage 1 and stage 2 specifications of ANF-CMN. The stage 1 specification (clause 6) specifies the additional network feature as seen by users of the feature. The stage 2 specification (clause 7) identifies the functional entities involved in the additional network feature and the information flows between them.

## 2 Conformance

In order to conform to this Standard, a stage 3 standard shall specify signalling protocols and equipment behaviour that are capable of being used in a PISN which supports the additional network feature specified in this Standard. This means that, to claim conformance, a stage 3 standard is required to be adequate for the support of those aspects of clause 6 (stage 1) and clause 7 (stage 2) which are relevant to the interface or equipment to which the stage 3 standard applies.

## 3 References (normative)

The following standards contain provisions which, through reference in this text, constitute provision of this Standard. All standards are subject to revision, and parties to agreements based on this Standard are encouraged to investigate the possibility of applying the most recent editions of the standards indicated below.

ISO/IEC 11574	Information technology - Telecommunications and information exchange between systems - Private Integrated Services Network - Circuit-mode 64 kbit/s bearer services - Service description, functional capabilities and information flows (1994)
ISO/IEC 11579-1	Information technology - Telecommunications and information exchange between systems - Private Integrated Services Network - Part 1: Reference configuration for PISN Exchanges (PINX) (1994)
ETS 300 387	Private Telecommunication Network (PTN); Method for the specification of basic and supplementary services (1994)
CCITT Rec. I.112	Vocabulary of terms for ISDNs (1988)
CCITT Rec. I.210	Principles of telecommunication services supported by an ISDN and the means to describe them (1988)
CCITT Rec. Z.100	Specification and description language (1988)

## 4 Definitions

For the purpose of this Standard the following definitions apply.

### 4.1 External definitions

This Standard uses the following terms defined in other documents:

- Basic Service (CCITT Rec. I.210)
- Connection (CCITT Rec. I.112)
- Private Integrated Services Network (PISN) (ISO/IEC 11579-1)

- Private Integrated Services Network Exchange (PINX) (ISO/IEC 11579-1)
- Service (CCITT Rec. I.112)
- Signalling (CCITT Rec. I.112)
- Supplementary Service (CCITT Rec. I.210)
- User (except in the context of ANF-CMN user) (ISO/IEC 11574)

This Standard refers to the following basic call functional entities (FEs) defined in ISO/IEC 11574:

- Call Control (CC)
- Call Control Agent (CCA)

This Standard refers to the following basic call inter-FE relationships defined in ISO/IEC 11574:

- r1
- r2
- r3

This Standard refers to the following basic call information flows defined in ISO/IEC 11574:

- SETUP request/indication
- SETUP response/confirmation

#### **4.2 Additional Network Feature**

A capability, over and above that of a basic service, provided by a PISN, but not directly to a PISN user.

#### **4.3 ANF-CMN User**

An entity that acts on behalf of one end of a connection through a PISN by using ANF-CMN to exchange Common Information with a peer entity acting on behalf of the other end of the connection.

#### **4.4 Backward direction**

Within the context of a call, the direction from the called user towards the calling user.

#### **4.5 Call, Basic Call**

An instance of the use of a basic service.

#### **4.6 Common Information**

Information relating to the user or equipment at one end of a connection through a PISN. This information includes one or more of the following: Feature Identifiers, Party Category, Equipment Identity.

#### **4.7 Feature Identifier**

In the context of a particular call, an indication of the availability of a supplementary service or ANF or of a particular capability of a supplementary service or ANF.

#### **4.8 Forward direction**

Within the context of a call, the direction from the calling user towards the called user.

#### **4.9 Equipment Identity**

A unique identity, three-level structured consisting of Node identity, Group identity, Unit identity.

#### **4.10 Node Identity**

The identity of the PINX at which a unit of equipment is located.

#### **4.11 Group Identity**

Within the context of a PINX, the identity of the group of equipment to which a unit of equipment belongs.

#### **4.12 Unit Identity**

Within the context of a PINX or a group of equipment within a PINX, the identity of a unit of equipment.

#### **4.13 Party Category**

Indicates the category of a party involved in a call.

##### *NOTE*

*The purpose of the Party Category is to indicate to the other end of a connection the category of a user involved in a call. A received Party Category information may be used for display at the user's terminal or for the PISN-internal call handling process, e.g. depending whether the calling party is an extension or PISN attendant, the call handling may invoke different options of a supplementary service related to that call.*

### **5 List of acronyms**

ANF	Additional Network Feature
ANF-CMN	Additional Network Feature Common Information
CC	Call Control (functional entity)
CCA	Call Control Agent (functional entity)
FE	Functional Entity
FI	Feature Identifier
ISDN	Integrated Services Digital Network
PINX	Private Integrated Services Network Exchange
PISN	Private Integrated Services Network
SDL	Specification and Description Language
SS	Supplementary Service

### **6 ANF-CMN stage 1 specification**

#### **6.1 Description**

##### **6.1.1 General description**

ANF-CMN is an additional network feature which enables the exchange of Common Information between ANF-CMN users acting on behalf of the two ends of a connection through a PISN. This Common Information relates to the user or equipment at one end of a connection and includes one or more of the following: Feature Identifiers, Party Category, Equipment Identity. This information, when received by an ANF-CMN user, can be used for any purpose, e.g. as the basis for indications to the local user or to another network or in order to filter feature requests.

A solicited and an unsolicited service can be offered to an ANF-CMN user.

The solicited service enables the ANF-CMN user to request the Common Information from a peer ANF-CMN user.

The unsolicited service enables an ANF-CMN user to supply Common Information to a peer ANF-CMN user.

These services may be combined and are not mutually exclusive.

##### **6.1.2 Qualifications on Applicability to Telecommunication Services**

ANF-CMN is applicable to all circuit-mode basic services defined in ISO/IEC 11574.

#### **6.2 Procedures**

##### **6.2.1 Provision/Withdrawal**

ANF-CMN shall be PISN instigated.

## **6.2.2 Normal procedures**

### **6.2.2.1 Activation/Deactivation/Registration/Interrogation**

Not applicable.

### **6.2.2.2 Invocation and operation**

The conditions under which ANF-CMN is invoked shall be an implementation matter. Also, Common Information offered by a PISN shall be an implementation matter.

An ANF-CMN user may invoke ANF-CMN at any time during a call

- to send its own Common Information to the peer ANF-CMN user (unsolicited service), or
- to request the Common Information of the peer ANF-CMN user (solicited service).

Sending and requesting the Common Information may be combined.

#### *NOTE*

*Typically the Common Information is exchanged during the establishment of a call.*

On receiving a request for Common Information the receiving ANF-CMN user shall respond with its Common Information.

## **6.2.3 Exceptional procedures**

### **6.2.3.1 Activation/Deactivation/Registration/Interrogation**

Not applicable.

### **6.2.3.2 Invocation and Operation**

If no response is received on a request for Common Information (solicited service), the action to be taken shall be implementation dependent.

## **6.3 Interactions with other Supplementary Services and ANFs**

Interactions with other supplementary services and ANFs for which PISN standards were available at the time of publication of this Standard as specified below.

### **6.3.1 Calling Line Identification Presentation (CLIP)**

No interaction.

### **6.3.2 Connected Line Identification Presentation (COLP)**

No interaction.

### **6.3.3 Calling/Connected Line Identification Restriction (CLIR)**

No interaction.

### **6.3.4 Calling Name Identification Presentation (CNIP)**

No interaction.

### **6.3.5 Connected Name Identification Presentation (CONP)**

No interaction.

### **6.3.6 Calling/Connected Name Identification Restriction (CNIR)**

No interaction.

### **6.3.7 Call Forwarding Unconditional (CFU)**

Common Information relating to the originating end of a call sent at the time of the call establishment request shall, if the call is diverted, be diverted to the ANF-CMN user at the terminating end of the diverted call.

### **6.3.8 Call Forwarding Busy (CFB)**

Clause 6.3.7 shall apply.

**6.3.9 Call Forwarding No Reply (CFNR)**

Unsolicited Common Information relating to the originating end of a call sent at the time of the call establishment request shall, if the call is diverted, be diverted to the ANF-CMN user at the terminating end of the diverted call.

A request for solicited Common Information relating to the originating end of a call sent at the time of the call establishment request shall not, if the call is diverted, be diverted to the ANF-CMN user at the terminating end of the diverted call.

**6.3.10 Call Deflection (CD)**

In case of Call Deflection immediate, clause 6.3.7 shall apply.

In case of Call Deflection on alerting, clause 6.3.9 shall apply.

**6.3.11 Call Transfer (CT)**

No interaction.

*NOTE*

*ANF-CMN users involved in a call resulting from Call Transfer may exchange Common Information subsequent to transfer.*

**6.3.12 Completion of Calls to Busy Subscriber (CCBS)**

No interaction.

**6.3.13 Completion of Calls on No Reply (CCNR)**

No interaction.

**6.3.14 Call Intrusion (CI)**

No interaction.

**6.3.15 Call Offer (CO)**

No interaction.

**6.3.16 Do Not Disturb (DND)**

No interaction.

**6.3.17 Do Not Disturb Override (DNDO)**

No interaction.

**6.3.18 Call Interception (CINT)**

In case of Call Interception immediate, clause 6.3.7 shall apply.

In case of Call Interception delayed, clause 6.3.9 shall apply.

**6.3.19 Advice Of Charge (AOC)**

No interaction.

**6.3.20 Message Waiting Indication (MWI)**

No interaction.

**6.3.21 Path Replacement (PR)**

No interaction.

**6.3.22 Recall (RE)**

No interaction.

**6.3.23 Cordless Terminal Mobility, Outgoing call (CTMO)**

No interaction.

**6.3.24 Cordless Terminal Mobility, Incoming call (CTMI)**

Clause 6.3.7 shall apply.

**6.3.25 Cordless Terminal, Location Registration (CTRL)**

No interaction.

**6.3.26 Cordless Terminal, Authentication (CTAU)**

No interaction.

**6.3.27 Transit Counter (TC)**

No interaction.

**6.4 Interworking considerations**

On a call to or from another network both ANF-CMN users will be located within the PISN, with one ANF-CMN user acting on behalf of the other network. That ANF-CMN user may use information from the other network in compiling its own Common Information and may send some or all of the peer ANF-CMN user's Common Information to the other network.

**6.5 Overall SDL**

Figure 1 contains the dynamic description of ANF-CMN using the Specification and Description Language (SDL) defined in CCITT Rec. Z.100 (1988). The SDL process represents the behaviour of the network in providing ANF-CMN. The relationship of this process to the basic call process is indicated in the annotations.

Input signals from the left and output signals to the left represent primitives from and to the invoking ANF-CMN user.

Input signals from the right represent primitives from the non-invoking ANF-CMN user or from Basic Call.

Output signals to the right represent primitives to the non-invoking ANF-CMN user.

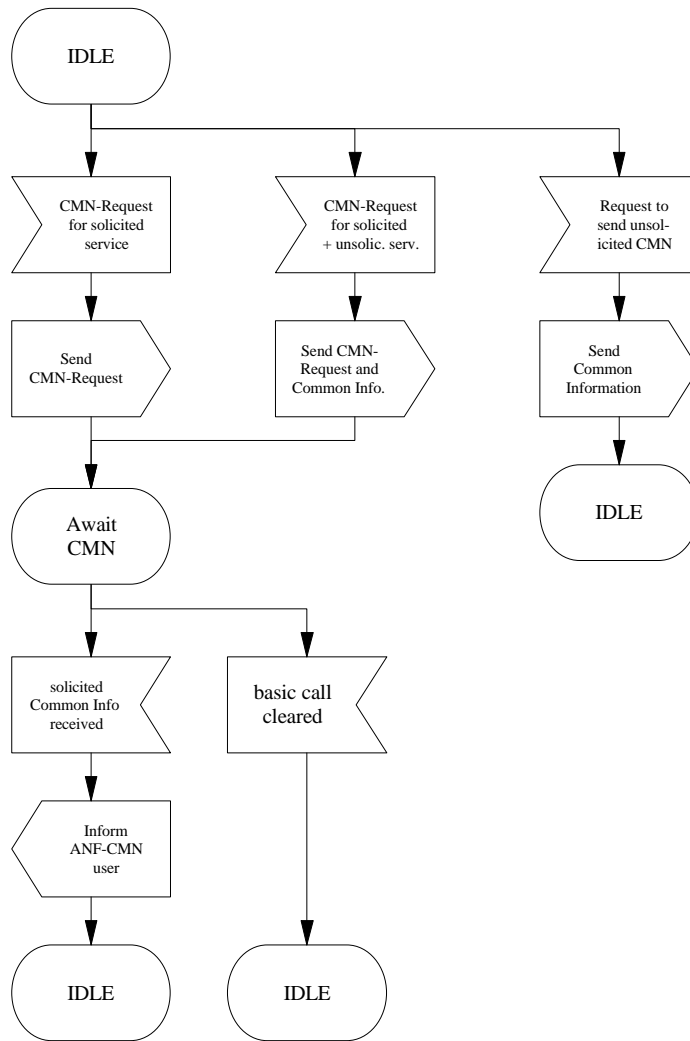

**Figure 1 - ANF-CMN, Overall SDL**

## 7 ANF-CMN stage 2 specification

### 7.1 Functional Model

#### 7.1.1 Functional Model Description

The functional model shall comprise the following functional entities (FEs):

FE1 ANF-CMN Invoke

FE2 ANF-CMN Remote

The following functional relationship shall exist between these FEs:

ra between FE1 and FE2

Figure 2 shows these FEs and this relationship.

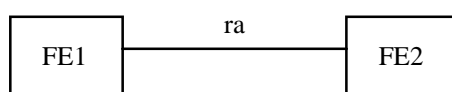

Figure 2 - Functional Model for ANF-CMN

#### 7.1.2 Description of Functional Entities

##### 7.1.2.1 ANF-CMN Invoke Functional Entity, FE1

This functional entity

- receives requests from the local ANF-CMN user
- for the solicited service:
  - sends a Common Information request to FE2
  - receives the response from FE2 and passes the received Common Information to the local ANF-CMN user.
- for the unsolicited service:
  - sends the Common Information to FE2.

##### 7.1.2.2 ANF-CMN Remote Functional Entity, FE2

This functional entity

- for the solicited service:
  - receives the Common Information request
  - obtains Common Information from the local ANF-CMN user and responds to FE1.
- for the unsolicited service:
  - receives the Common Information and passes it to the local ANF-CMN user.

#### 7.1.3 Relationship of Functional Model to Basic Call Functional Model

Functional entity FE1 is collocated with invoking ANF-CMN user's CC.

Functional entity FE2 is collocated with non-invoking ANF-CMN user's CC.

An example of a relationship between FEs for ANF-CMN and FEs for the basic call is shown in figure 3.



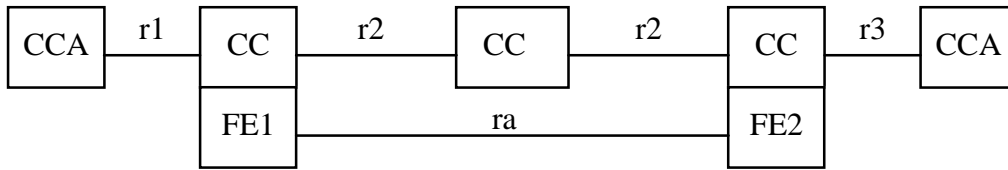

Figure 3 - Example Relationship between Model for ANF-CMN and Basic Call

## 7.2 Information Flows

### 7.2.1 Definition of Information Flows

In the tables listing the service elements in information flows, the column headed "Request" indicates which of these elements are mandatory (M) and which are optional (O) in a request/indication information flow, and the column headed "Confirm" (confirmed information flows only) indicates which of these elements are mandatory (M) and which are optional (O) in a response/confirmation information flow.

#### 7.2.1.1 ra-CMN-REQUEST

ra-CMN-REQUEST is a confirmed information flow across ra between FE1 and FE2 which is used to request the remote Common Information. The response contains the requested remote Common Information (solicited service).

Table 1 lists the service elements within the ra-CMN-REQUEST information flow. The contents of the service elements in table 1 are defined in 7.2.1.3.

Table 1 - Content of ra-CMN-REQUEST

Service element	Request	Confirm
FI-list	-	O (Note 1)
Equipment Id	-	O (Notes 1 + 2)
Party Category	-	O (Notes 1 + 2)

*NOTE 1*

*At least one of these three service elements shall be present within the ra-CMN-REQUEST confirmation.*

*NOTE 2*

*Equipment Id and Party Category in the ra-CMN-REQUEST confirmation are mutually exclusive. However, an Equipment Id may be used together with Party Category if the Party Category value is 'unknown'.*

#### 7.2.1.2 ra-CMN-INFORM

ra-CMN-INFORM is an unconfirmed information flow across ra from FE1 to FE2 which is used to send unsolicited Common Information.

Table 2 lists the service elements within the ra-CMN-INFORM information flow. The contents of the service elements in table 2 are defined in 7.2.1.3.

Table 2 - Content of ra-CMN-INFORM

Service element	Request
FI-list	O (Note 1)
Equipment Id	O (Notes 1 + 2)
Party Category	O (Notes 1 + 2)

*NOTE 1*

*At least one of these three service elements shall be present within the ra-CMN-INFORM request.*

*NOTE 2*

*Equipment Id and Party Category in the ra-CMN-INFORM request are mutually exclusive. However, an Equipment Id may be used together with Party Category if the Party Category value is 'unknown'.*

**7.2.1.3 Contents of Service Elements of ANF-CMN**

The service elements of ANF-CMN are listed in tables 3 and 4.

*NOTE*

*Future supplementary services or additional network features will specify the appropriate Feature Identifiers in their service descriptions.*

The service element FI-list, when used in forward direction, shall include one or more of the Feature Identifiers listed in table 3.

**Table 3 - Feature Identifiers in Forward Direction**

<b>Feature Identifiers</b>	<b>Values</b>	<b>Comments</b>
SS-CF re-routeing available	Yes/No	Call Forwarding
SS-CT re-routeing available	Yes/No	Call Transfer
SS-CI protection level	0 1 2 3	Call Intrusion
ANF-PR available at a co-operating PINX	Yes/No	Path Replacement
ANF-CINT can intercept - interception immediate	Yes/No	Call Interception
ANF-CINT can intercept - interception delayed	Yes/No	
ANF-CTMI re-routeing available	Yes/No	Cordless Terminal Incoming Call

The service element FI-list, when used in backward direction, shall include one or more of the Feature Identifiers listed in table 4.

**Table 4 - Feature Identifiers in Backward Direction**

Feature Identifiers	Values	Comments
SS-CT re-routeing available	Yes/No	Call Transfer
SS-CCBS available	Yes/No	Call Completion on Busy Subscriber
SS-CCNR available	Yes/No	Call Completion on No Reply
SS-CO available	Yes/No	Call Offer
SS-DNDO available	Yes/No	Do Not Disturb Override
SS-DNDO protection level	0 1 2 3	
SS-CI available	Yes/No	
SS-CI protection level	0 1 2 3	
<i>options:</i>		
SS-CI Forced Release available	Yes/No	Call Intrusion
SS-CI Isolation available	Yes/No	
SS-CI Wait on Busy available	Yes/No	
SS-AOC Support of charge rate provision at a gateway PINX	Yes/No	Advice Of Charge
SS-AOC Support of interim charge provision at a gateway PINX	Yes/No	
SS-AOC Support of final charge provision at a gateway PINX	Yes/No	
ANF-PR available at a co-operating PINX	Yes/No	Path Replacement

**Table 5 - Equipment Identity**

Parameter	Indication	Values	Mandatory / Optional Indication	Comments
Equipment Identity	Node Identity	alphanum. string	O	
	Group Identity	alphanum. string	O	
	Unit Identity	alphanum. string	O	

**Table 6 - Party Category**

Parameter	Values	Mandatory / Optional Indication	Comments
Party Category	Unknown Extension PISN attendant Emergency extension	O	(from ECMA-143)

**7.2.2 Relationship of Information Flows to Basic Call Information Flows**

When ra-CMN-REQUEST request/indication information flow is sent it shall be:

- together with a basic call information flow if this is sent at the same time,
- otherwise independently of a basic call information flow.

*NOTE*

*At call setup time ra-CMN-REQUEST is sent together with r2-SETUP request/indication.*

When ra-CMN-REQUEST response/confirmation information flow is sent it shall be:

- together with a basic call information flow if this is sent at the same time,
- otherwise independently of a basic call information flow.

When ra-CMN-INFORM request/indication information flow is sent it shall be:

- together with a basic call information flow if this is sent at the same time,
- otherwise independently of a basic call information flow.

**7.2.3 Information Flow Sequences**

A stage 3 standard for ANF-CMN shall provide signalling procedures in support of the information flow sequences specified below. In addition, signalling procedures should be provided to cover other sequences arising from error situations, interactions with basic call, interactions with other supplementary services and ANFs, different topologies, etc.

In the figures, ANF-CMN information flows are represented by solid arrows and basic call information flows are represented by broken arrows. An ellipse embracing two information flows indicates that the two information flows occur simultaneously. Within a column representing an ANF-CMN functional entity, the numbers refer to functional entity actions as listed in 7.3.

**7.2.3.1 Normal Operation of ANF-CMN**

Figure 4 shows an example of the information flow sequence for normal operation of ANF-CMN for the solicited service at call setup time.

Figure 5 shows an example of the information flow sequence for normal operation of ANF-CMN for the unsolicited service, independently of any basic call information flow.

Figure 6 shows an example of the information flow sequence for normal operation of ANF-CMN for a combination of the solicited and unsolicited service at call setup time.

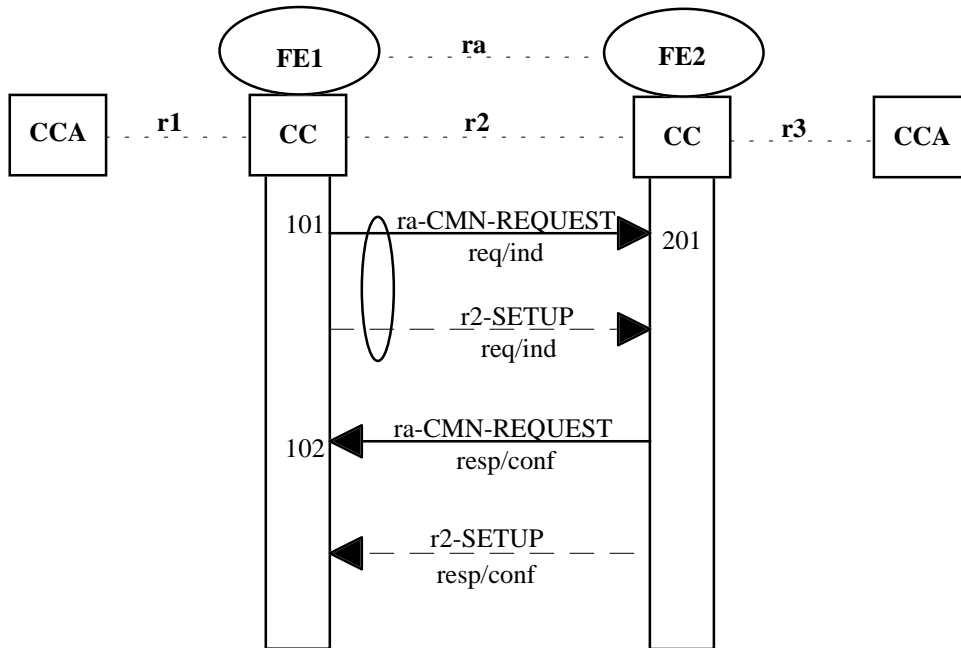

Figure 4 - Information Flow Sequence - Normal Operation of ANF-CMN

solicited service at call setup time

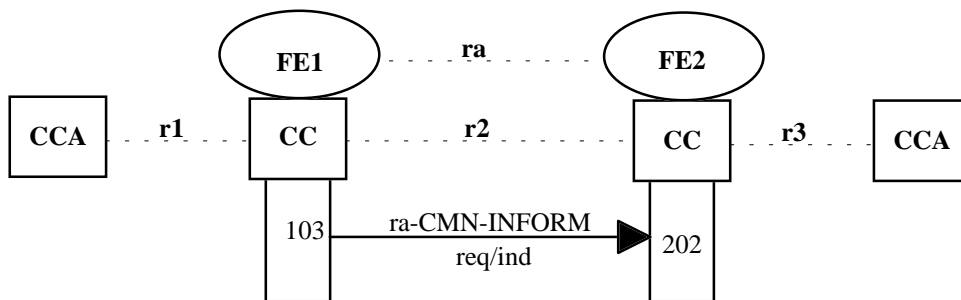
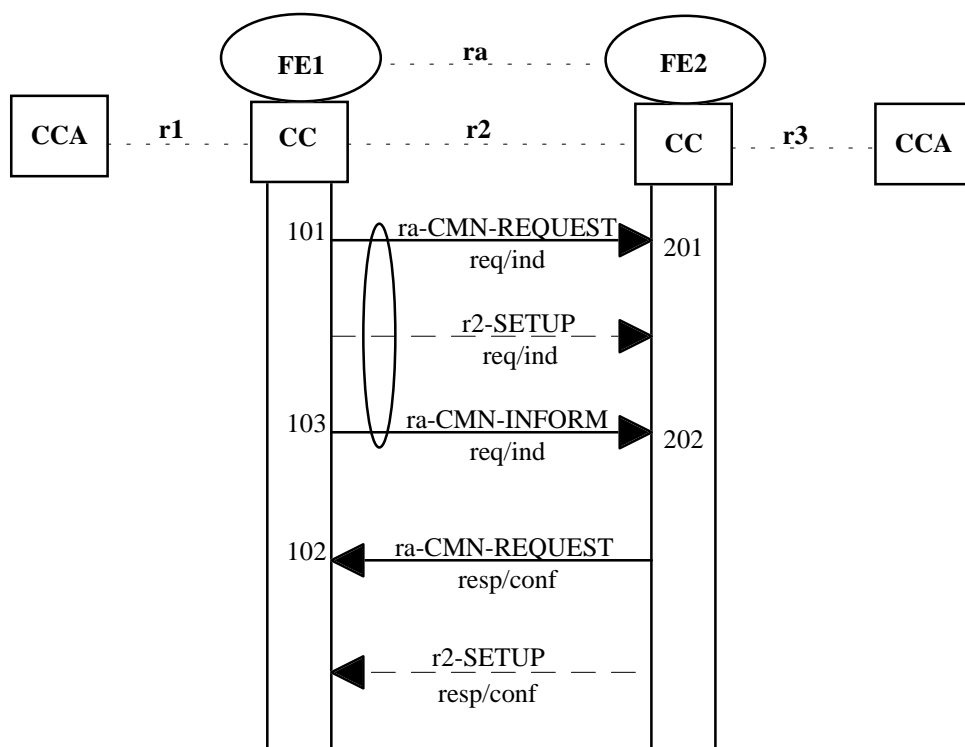

Figure 5 - Information Flow Sequence - Normal Operation of ANF-CMN

unsolicited service



**Figure 6 - Information Flow Sequence - Normal Operation of ANF-CMN**  
 combination of solicited and unsolicited service at call setup time

### 7.3 Functional entity actions

The following FE actions shall occur at the points indicated in the figures of 7.2.3.

#### 7.3.1 Functional entity actions of FE1

- 101 Send ra-CMN-REQUEST req/ind to FE2 in order to request Common Information from FE2.
- 102 Pass on the received Common Information to the requesting ANF-CMN user.
- 103 Obtain Common Information from the local ANF-CMN user and send ra-CMN-INFORM req/ind to FE2.

#### 7.3.2 Functional entity actions of FE2

- 201 On receipt of the request for Common Information obtain the Common Information from the local ANF-CMN user and send ra-CMN-REQUEST resp/conf to FE1.
- 202 Pass on the received Common Information to the local ANF-CMN user.

### 7.4 Functional entity behaviour

The FE behaviours shown below are intended to illustrate typical FE behaviour in terms of information flows sent and received.

The behaviour of each FE is shown using the Specification and Description Language (SDL) defined in CCITT Rec. Z.100 (1988).

### 7.4.1 Behaviour of FE1

Figure 7 shows the normal behaviour of FE1.

Input signals from the left and output signals to the left represent primitives from and to the ANF-CMN-user.

Input signals from the right represent information flows from FE2 or primitives from Basic Call. Output signals to the right represent information flows to FE2.

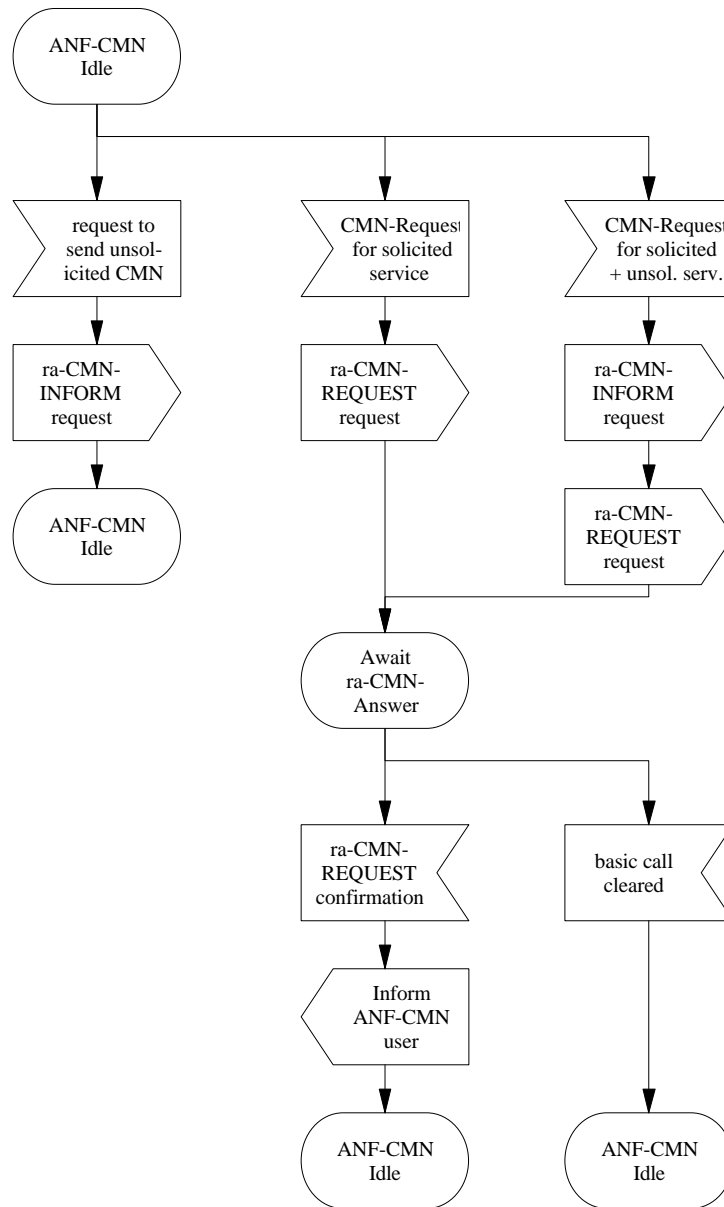
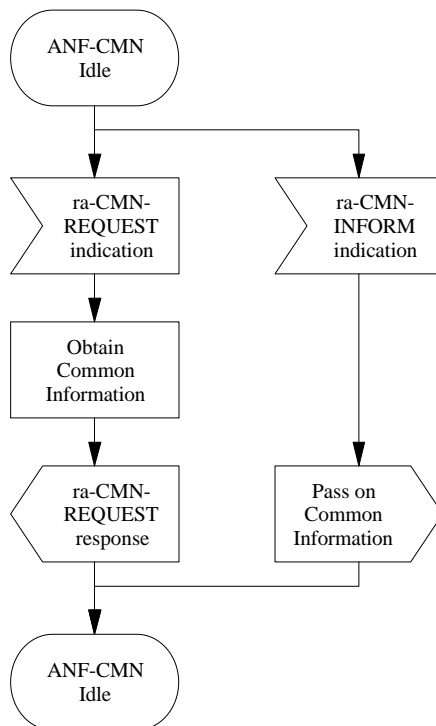

Figure 7 - ANF-CMN, SDL for Functional Entity FE1

**7.4.2 Behaviour of FE2**

Figure 8 shows the normal behaviour of FE2.

Output signals to the right represent primitives from and to the ANF-CMN user. Input signals from the left and output signals to the left represent information flows to and from FE1.



**Figure 8 - ANF-CMN, SDL for Functional Entity FE2**

**7.5 Allocation of Functional Entities to Physical Equipment**

The allocations of FEs to physical equipment shown in table 7 shall apply.

**Table 7 - Scenarios for the Allocation of FEs to Physical Equipment**

	FE1	FE2
Scenario 1	Originating PINX	Terminating PINX
Scenario 2	Terminating PINX	Originating PINX

**7.6 Interworking considerations**

When interworking with another network, both FE1 and FE2 will be located within the PISN (table 8, scenarios 3 - 6).

On an incoming call from another network:

- Scenario 3 applies if ANF-CMN is invoked in forward direction,
- Scenario 4 applies if ANF-CMN is invoked in backward direction.

On an outgoing call to another network:

- Scenario 5 applies if ANF-CMN is invoked in forward direction,
- Scenario 6 applies if ANF-CMN is invoked in backward direction.



**Table 8 - Scenarios for the allocation of FEs to physical equipment for normal operation in the case of interworking with another network**

	FE1	FE2
Scenario 3	Incoming Gateway PINX	Terminating PINX
Scenario 4	Terminating PINX	Incoming Gateway PINX
Scenario 5	Originating PINX	Outgoing Gateway PINX
Scenario 6	Outgoing Gateway PINX	Originating PINX
Scenario 7	Incoming Gateway PINX	Outgoing Gateway PINX
Scenario 8	Outgoing Gateway PINX	Incoming Gateway PINX







Printed copies can be ordered from:

**ECMA**

114 Rue du Rhône  
CH-1204 Geneva  
Switzerland

Fax: +41 22 849.60.01

Internet: [helpdesk@ecma.ch](mailto:helpdesk@ecma.ch)

Files can be downloaded from our FTP site, [ftp.ecma.ch](ftp://ftp.ecma.ch), logging in as **anonymous** and giving your E-mail address as **password**. This Standard is available from library **ECMA-ST** as a compacted, self-expanding file in MSWord 6.0 format (file E250-DOC.EXE) and as an Acrobat PDF file (file E250-PDF.PDF). File E250-EXP.TXT gives a short presentation of the Standard.

Our web site, <http://www.ecma.ch>, gives full information on ECMA, ECMA activities, ECMA Standards and Technical Reports.

**ECMA**

**114 Rue du Rhône  
CH-1204 Geneva  
Switzerland**

**This Standard ECMA-250 is available free of charge in printed form{ and as a file}.**

**See inside cover page for instructions**