

Standard ECMA-331

2nd Edition / June 2004

**Cases for 120 mm and
80 mm DVD-RAM Disks**

Standard

Standard
ECMA-331

2nd Edition / June 2004

**Cases for 120 mm and
80 mm DVD-RAM Disks**

Brief history

Ecma Technical Committee TC31 was established in 1984 for the standardization of Optical Disks and Optical Disk Cartridges (ODC). Since its establishment, the Committee has made major contributions to ISO/IEC toward the development of International Standards for 80 mm, 90 mm, 120 mm, 130 mm, 300 mm, and 356 mm media. Numerous standards have been developed by TC31 and published by Ecma, almost all of which have also been adopted by ISO/IEC under the fast-track procedure. In February 1997 a group of ten Companies, known as the DVD Forum, proposed to TC31 to develop standards for the optical disks known as DVD disks. TC31 accepted this proposal and started the work that has led to two Ecma Standards that have been adopted by ISO/IEC under the fast-track procedure as International Standards.

ECMA-267 (2001) 120 mm DVD-Read-Only Disk
ISO/IEC 16448

ECMA-268 (2001) 80 mm DVD-Read-Only Disk
ISO/IEC 16449

Further work, supported by nine members of the DVD Forum, has been undertaken for a rewritable disk known as DVD-RAM has led to two further Ecma and ISO/IEC Standards

ECMA-272 (1999) 120 mm DVD Rewritable Disk (DVD-RAM)
ISO/IEC 16824

ECMA-273 (1998) Case for 120 mm DVD-RAM Disks
ISO/IEC 16825

A new Standard ECMA-330 constituting a further development of Standard ECMA-272 proposed to, and accepted by, Ecma/TC31 on presentation by Toshiba Corporation on behalf of ten other Member Companies of the DVD Forum has been undertaken by Ecma/TC31. The development of the present Standard ECMA-331 was also proposed and accepted at the same time. It shall specify a case for use with the disks specified in Standard ECMA-330 so as to form an optical disk cartridge. Several Types are specified that allow meeting the requirements of different applications for which such cartridges are used.

This Ecma Standard has been adopted by the General Assembly of June 2004.

Table of contents

Section 1 – General	1
1 Scope	1
2 Conformance	1
3 Normative references	1
4 Definitions	2
4.1 Cartridge	2
4.2 Case	2
5 Conventions and notations	2
5.1 Representation of numbers	2
5.2 Names	2
6 General description of the case	2
6.1 General description of the Type 1 case (Figure 1)	2
6.2 General description of the Type 2 case (Figure 2)	2
6.3 General description of the Type 3 case (Figure 2)	3
6.4 General description of the Type 4 case (Figure 3)	4
6.5 General description of the Type 5 case (Figure 3)	5
6.6 General description of the Type 6 case (Figure 4)	5
6.7 General description of the Type 7 case (Figure 5)	6
6.8 General description of the Type 8 case (Figure 4)	6
6.9 General description of the Type 9 case (Figure 5)	6
7 General requirements	7
7.1 Environments	7
7.1.1 Test environment	7
7.1.2 Operating environment	7
7.1.3 Storage environment	8
7.1.4 Transportation	8
7.2 Temperature shock	8
7.3 Safety requirement	8
7.4 Flammability	8

Section 2 – Dimensional and mechanical characteristics of the case for 120 mm disks **8**

8	Dimensional characteristics	8
8.1	Dimensions of the Type 1 case	9
8.1.1	Overall dimensions (Figure 6)	9
8.1.2	Location hole (Figure 6)	10
8.1.3	Alignment hole (Figure 6)	10
8.1.4	Reference surfaces (Figure 7)	10
8.1.5	Insertion slots (Figure 8)	11
8.1.6	Detents (Figure 8)	11
8.1.7	Gripper slots (Figure 8)	12
8.1.8	Write-inhibit hole (Figure 9)	12
8.1.9	Sensor holes (Figure 9)	12
8.1.10	Sensing areas (Figure 9)	13
8.1.11	Spindle and head window (Figure 10)	13
8.1.12	Shutter shape (Figure 11)	14
8.1.13	Path for shutter opener (Figures 12 and 13)	15
8.1.14	Label areas (Figure 14)	15
8.1.15	Identification marks for Sides A and B (Figure 15)	16
8.2	Dimensions of the Type 2 case	27
8.2.1	Overall dimensions (Figure 16)	27
8.2.2	Location hole (Figure 16)	28
8.2.3	Alignment hole (Figure 16)	28
8.2.4	Reference surfaces (Figure 17)	28
8.2.5	Insertion slot (Figure 18)	29
8.2.6	Detents (Figure 18)	29
8.2.7	Gripper slots (Figure 18)	30
8.2.8	Write-inhibit hole (Figure 19)	30
8.2.9	Sensor holes (Figure 19)	31
8.2.10	Sensing areas (Figure 19)	31
8.2.11	Spindle and head window (Figure 20)	31
8.2.12	Shutter shape (Figure 21)	32
8.2.13	Path for shutter opener (Figure 22 and 23)	33
8.2.14	Label areas (Figure 24)	33
8.2.15	Identification mark for Side A (Figure 25)	34
8.2.16	Opening and opening cover for taking the disk out of the case	34
8.3	Dimensions of the Type 3 case	44
8.3.1	Sensor holes	44
8.3.2	Opening and opening cover for taking the disk out of the case	45
8.4	Dimensions of the Type 4 case	45
8.4.1	Sensor holes	45
8.4.2	Opening and opening cover for taking the disk out of the case	45
8.5	Dimensions of the Type 5 case	45
8.5.1	Sensor holes	46

8.5.2	Opening and opening cover for taking the disk out of the case	46
9	Mechanical characteristics	46
9.1	Material	46
9.2	Mass	46
9.3	Edge distortion	46
9.4	Compliance	46
9.5	Shutter opening force	46
10	Interface between the case used as cartridge and a drive	47
10.1	Capture cylinder (Figure 26)	47
10.2	Inner dimensions of the case (Figure 27)	48
11	Orientation of the disk in the case	49
11.1	Two-sided disk (Type 2S) in case Types 1, 4 and 5	49
11.2	One-sided disk (Type 1S) in case Types 1, 2 and 3	49
Section 3 – Dimensional and Mechanical characteristics of the case for 80 mm disk		51
12	Dimensional characteristics	51
12.1	Dimensions of the Type 6 case	51
12.1.1	Overall dimensions (Figure 28)	51
12.1.2	Location hole (Figure 28)	52
12.1.3	Alignment hole (Figure 28)	52
12.1.4	Reference surfaces (Figure 29)	52
12.1.5	Mis-insertion protection slots (Figure 30)	53
12.1.6	Detents (Figure 30)	53
12.1.7	Write-inhibit hole (Figure 31)	54
12.1.8	Sensor holes (Figure 31)	54
12.1.9	Spindle and head window (Figure 32)	55
12.1.10	Shutter shape (Figure 33)	56
12.1.11	Path for shutter opener (Figure 34)	57
12.1.12	Label areas (Figure 35)	57
12.1.13	Identification marks for Sides A and B (Figure 36)	58
12.1.14	Disk holder and body (Figures 37 and 38)	58
12.2	Dimensions of the Type 7 case	72
12.2.1	Overall dimensions (Figure 39)	72
12.2.2	Location hole (Figure 40)	72
12.2.3	Alignment hole (Figure 40)	73
12.2.4	Reference surfaces (Figure 40)	73
12.2.5	Mis-insertion protection slots (Figure 41)	73
12.2.6	Detents (Figure 41)	74
12.2.7	Write-inhibit hole (Figure 42)	75

12.2.8	Sensor holes (Figure 42)	75
12.2.9	Spindle and head window (Figure 43)	76
12.2.10	Shutter shape (Figure 44)	77
12.2.11	Path for shutter opener (Figure 45)	78
12.2.12	Label areas (Figure 46)	78
12.2.13	Identification marks for Sides A and B (Figure 47)	78
12.2.14	Disk holder and body (Figure 48)	79
12.3	Dimensions of the Type 8 case	93
12.3.1	Sensor holes	93
12.3.2	Disk holder and body	93
12.4	Dimensions of the Type 9 case	93
12.4.1	Sensor holes	93
12.4.2	Disk holder and body	93
13	Mechanical characteristics	94
13.1	Material	94
13.2	Mass	94
13.3	Edge distortion	94
13.4	Compliance	94
13.5	Shutter opening force	94
14	Interface between the case used as cartridge and a drive	94
14.1	Capture cylinder (Figure 50)	94
14.2	Inner dimensions of the case (Figure 51)	94
15	Orientation of the disk in the case	95
15.1	Two-sided disk (Type 2S) in case Types 6 and 8	95
15.2	One-sided disk (Type 1S) in case Types 7 and 9	95
Annex A (normative) - Position of the case for 120 mm disk relative to the Reference Planes		99
Annex B (normative) - Edge distortion test of the case for 120 mm disk		101
Annex C (normative) - Compliance test of the case for 120 mm disk		103
Annex D (normative) - Position of the case for 80 mm disk relative to the Reference Planes		105
Annex E (normative) - Edge distortion test of the case for 80 mm disk		107
Annex F (normative) - Compliance test of the case for 80 mm disk		109
Annex G (normative) - Shutter opening force test of the case for 80 mm disk		111

Annex H (informative) - Examples of an opening cover for a Type 2 case, a Type 3 case, a Type 4 case or a Type 5 case	113
Annex J (informative) - Connection between disk holder and body of the case for 80 mm disk	115
Annex K (informative) - Transportation	117

Section 1 – General

1 Scope

This Ecma Standard specifies the characteristics of a case for use with the 120 mm and 80 mm DVD-RAM disks specified in Standard ECMA-330. The present Ecma Standard specifies nine related, but different implementations of this case, viz.

- Type 1** A case for a one-sided (Type 1S) or a two-sided (Type 2S) 120 mm DVD-RAM disk such that the disk cannot be removed from the case. This case is reversible.
- Type 2** A case for a one-sided (Type 1S) 120 mm DVD-RAM disk such that the disk may be removed from the case. This case is not reversible.
- Type 3** A case into which a one-sided (Type 1S) or a two-sided (Type 2S) 120 mm DVD-RAM disk may be inserted, then used as a cartridge. This case is not reversible.
- Type 4** A case for a two-sided (Type 2S) 120 mm DVD-RAM disk such that the disk may be removed from the case. This case is reversible.
- Type 5** A case into which a one-sided (Type 1S) or a two-sided (Type 2S) 120 mm DVD-RAM disk may be inserted, then used as a cartridge. This case is reversible.
- Type 6** A case for a two-sided (Type 2S) 80 mm DVD-RAM disk such that the disk may be removed from the case. This case is reversible.
- Type 7** A case for a one-sided (Type 1S) 80 mm DVD-RAM disk such that the disk may be removed from the case. This case is not reversible.
- Type 8** A case into which a two-sided (Type 2S) 80 mm DVD-RAM disk may be inserted, then used as a cartridge. This case is reversible.
- Type 9** A case into which a one-sided (Type 1S) 80 mm DVD-RAM disk may be inserted, then used as a cartridge. This case is not reversible.

This Ecma Standard specifies

- the environments in which the cases are to be operated and stored;
- the dimensional and mechanical characteristics of the case, so as to provide mechanical interchangeability between data processing systems.

This Ecma Standard provides for mechanical interchange between optical disk drives. Together with Standard ECMA-330 for 120 mm (4,7 Gbytes per side) and 80 mm (1,46 Gbytes per side) DVD-RAM disks and a standard for volume and file structure, it provides for full data interchange between data processing systems.

2 Conformance

A claim of conformance with this Ecma Standard shall specify the Type implemented. A case shall be in conformance with this Ecma Standard if it meets the mandatory requirements specified herein for its Type.

3 Normative references

The following referenced documents are indispensable for the application of this document. For dated references, only the edition cited applies. For undated references, the latest edition of the referenced document (including any amendments) applies.

- | | |
|-----------------|---|
| ECMA-330 (2002) | 120 mm (4,7 Gbytes per side) and 80 mm (1,46 Gbytes per side) DVD Rewritable Disk (DVD-RAM) |
| ECMA-287 (2002) | Safety of electronic equipment |
-

4 Definitions

For the purpose of this Ecma Standard the following definitions apply:

4.1 Cartridge

A device consisting of a case containing a rewritable disk.

4.2 Case

The housing for an optical disk, that protects the disk and facilitates disk interchange.

5 Conventions and notations

5.1 Representation of numbers

A measured value is rounded off to the least significant digit of the corresponding specified value. For instance, it implies that a specified value of 1,26 with a positive tolerance of + 0,01 and a negative tolerance of - 0,02 allows a range of measured values from 1,235 to 1,275.

5.2 Names

The names of entities, e.g. specific sides, etc. are given a capital initial.

6 General description of the case

6.1 General description of the Type 1 case (Figure 1)

The case is a rigid protective container of rectangular shape. Sides A and B of the case are identical as far as the features given here are concerned. References to Sides A and B of the case can be changed to B or A, respectively. When the opening of the one is a head and spindle window for the spindle and the optical head of the drive, that of the other is an access window for the disk clamping apparatus. A shutter uncovers the windows upon insertion into the drive, and automatically covers them upon removal from the drive. The case has features that enable a drive to reject a mis-inserted cartridge, to inhibit writing, sensor holes, detents for autoloading and a vertical use, gripper slots for an autochanger, label areas and side identification marks.

Sides A and B of the case have the same configuration.

6.2 General description of the Type 2 case (Figure 2)

The Type 2 case has the same features as the Type 1 case, but with some differences. The shape of the case is different on Side A and on Side B. Side A does not need to have a location hole, an alignment hole, Reference Surfaces, a write-inhibit hole, sensor holes and sensing areas. The case has an opening closed by a cover. This cover can be opened. In open position, the disk can be taken out of the case. Sensor hole A1 is originally closed. If the disk has been removed from the case, then this hole remains permanently open, indicating that the original disk contained in the case has been removed at least once or has been replaced by another disk.

6.3 General description of the Type 3 case (Figure 2)

The Type 3 case is identical with Type 2 case except that the sensor hole A1 is always open.

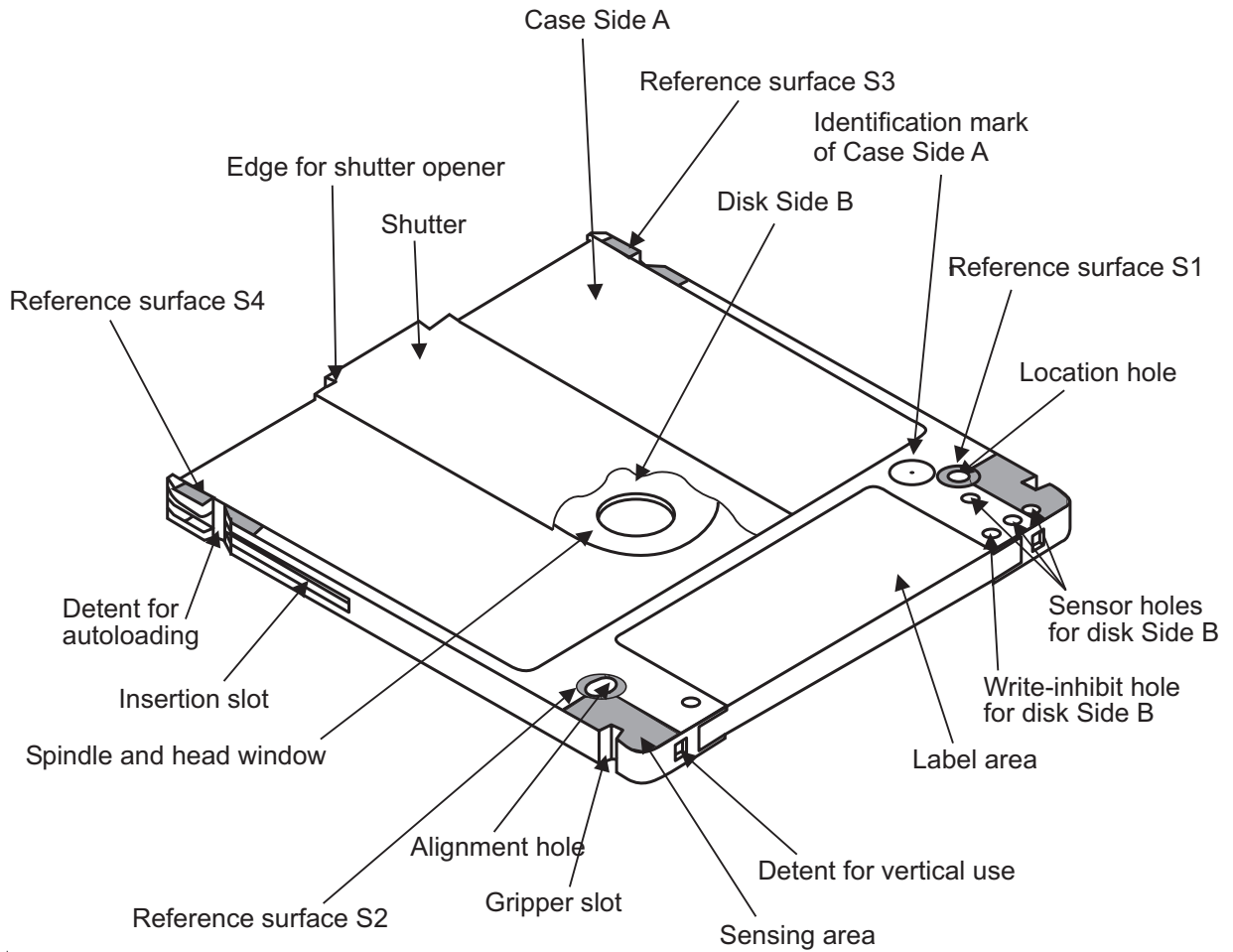

01-0088-A

Figure 1 - General view of the Type 1 case, seen from Side A

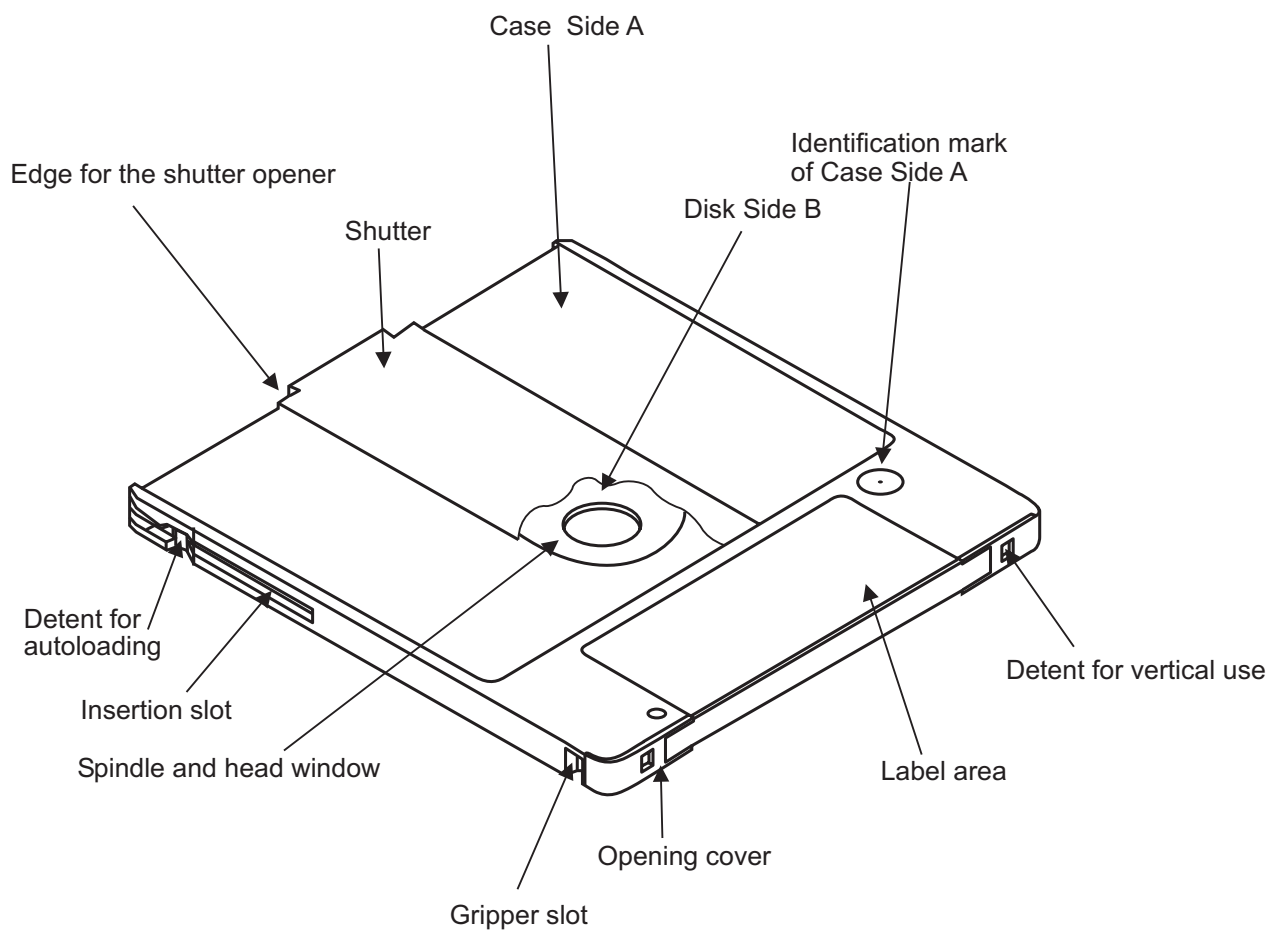

01-0089-A

Figure 2 - General view of the Type 2 and Type 3 cases, seen from Side A

6.4 General description of the Type 4 case (Figure 3)

The Type 4 case has the same features as the Type 1 case, but with some differences. The case has an opening closed by a cover. This cover can be opened. In open position, the disk can be taken out of the case. If the disk has been removed from the case, then the sensor hole A1 and B1 remain permanently open, indicating that the original disk contained in the case has been removed at least once or has been replaced by another disk.

6.5 General description of the Type 5 case (Figure 3)

The Type 5 case is identical with Type 4 case except that the sensor hole A1 and B1 are always open.

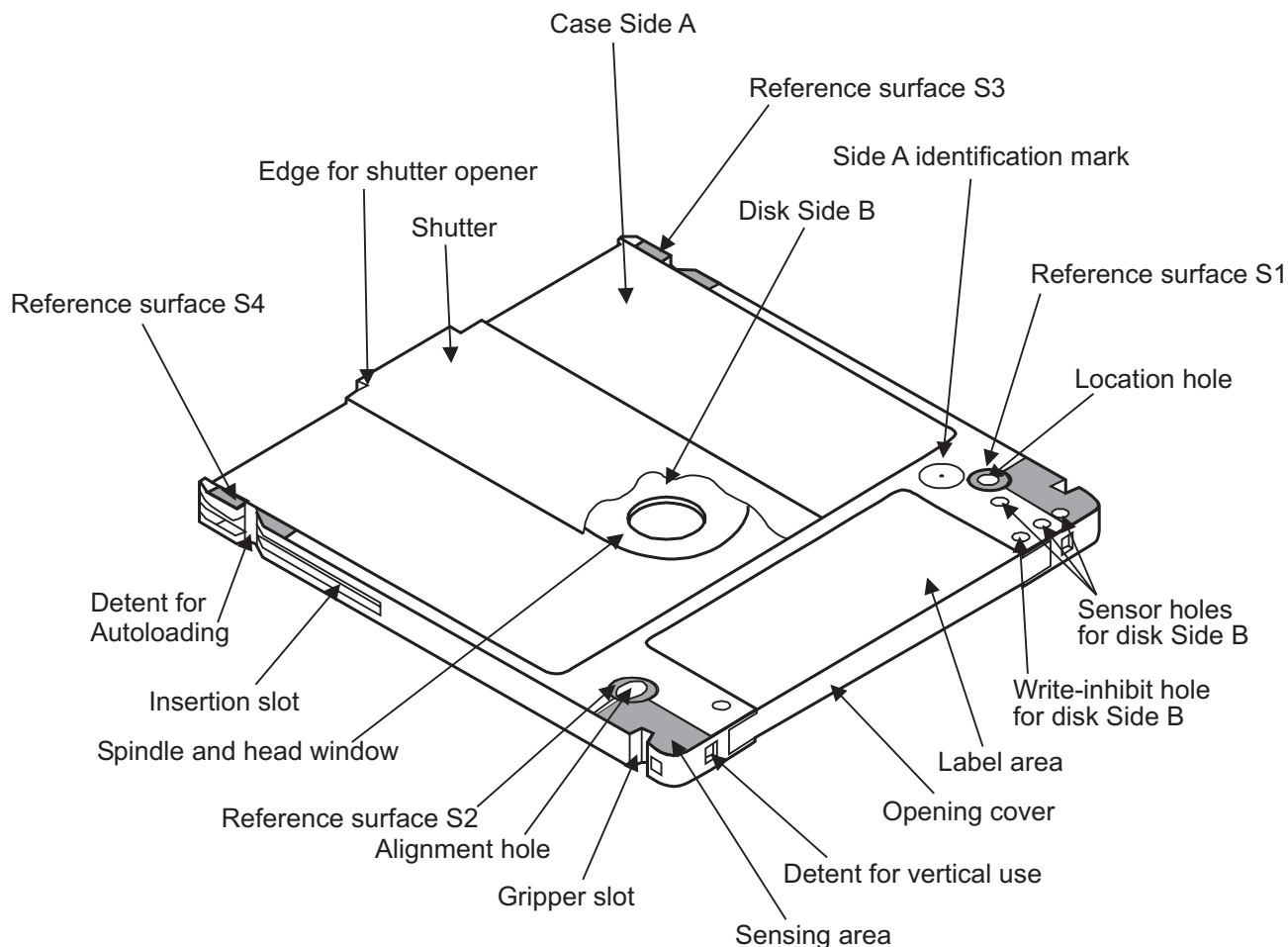

01-0045-A

Figure 3 - General view of the Type 4 and Type 5 cases, seen from Side A

6.6 General description of the Type 6 case (Figure 4)

The case is a rigid protective container of rectangular shape. It consists of a body and a disk holder. This disk holder can be taken out of the body and then the disk can be taken out of the case. Sensor hole A1 and B1 are originally closed. If the disk holder has been taken out of the body, then these holes remain permanently open, indicating that the original disk contained in the case has been removed at least once or has been replaced by another disk. Sides A and B of the case are identical as far as the features given here are concerned. References to Sides A and B of the case can be changed to B or A, respectively. When the opening of the one is a head and spindle window for the spindle and the optical head of the drive, that of the other is an access window for the disk clamping apparatus. A shutter uncovers the windows upon insertion into the drive, and automatically covers them upon removal from the drive. The case has features that enable a drive to reject a mis-inserted cartridge, to inhibit writing, sensor holes, detents for autoloading and a vertical use, gripper slots for an autochanger, label areas and side identification marks.

Sides A and B of the case have the same configuration.

6.7 General description of the Type 7 case (Figure 5)

The Type 7 case has the same features as the Type 6 case, but with some differences. The shape of the case is different on Side A and on Side B. Side A does not need to have a location hole, an alignment hole, Reference Surfaces, a write-inhibit hole, sensor holes and sensing areas. Sensor hole A1 is originally closed. If the disk holder has been taken out of the body, then this hole remains permanently open, indicating that the original disk contained in the case has been removed at least once or has been replaced by another disk. Side B of this case shall not have label area.

6.8 General description of the Type 8 case (Figure 4)

The Type 8 case is identical with Type 6 case except that the sensor hole A1 and B1 are always open.

6.9 General description of the Type 9 case (Figure 5)

The Type 9 case is identical with Type 7 case except that the sensor hole A1 is always open.

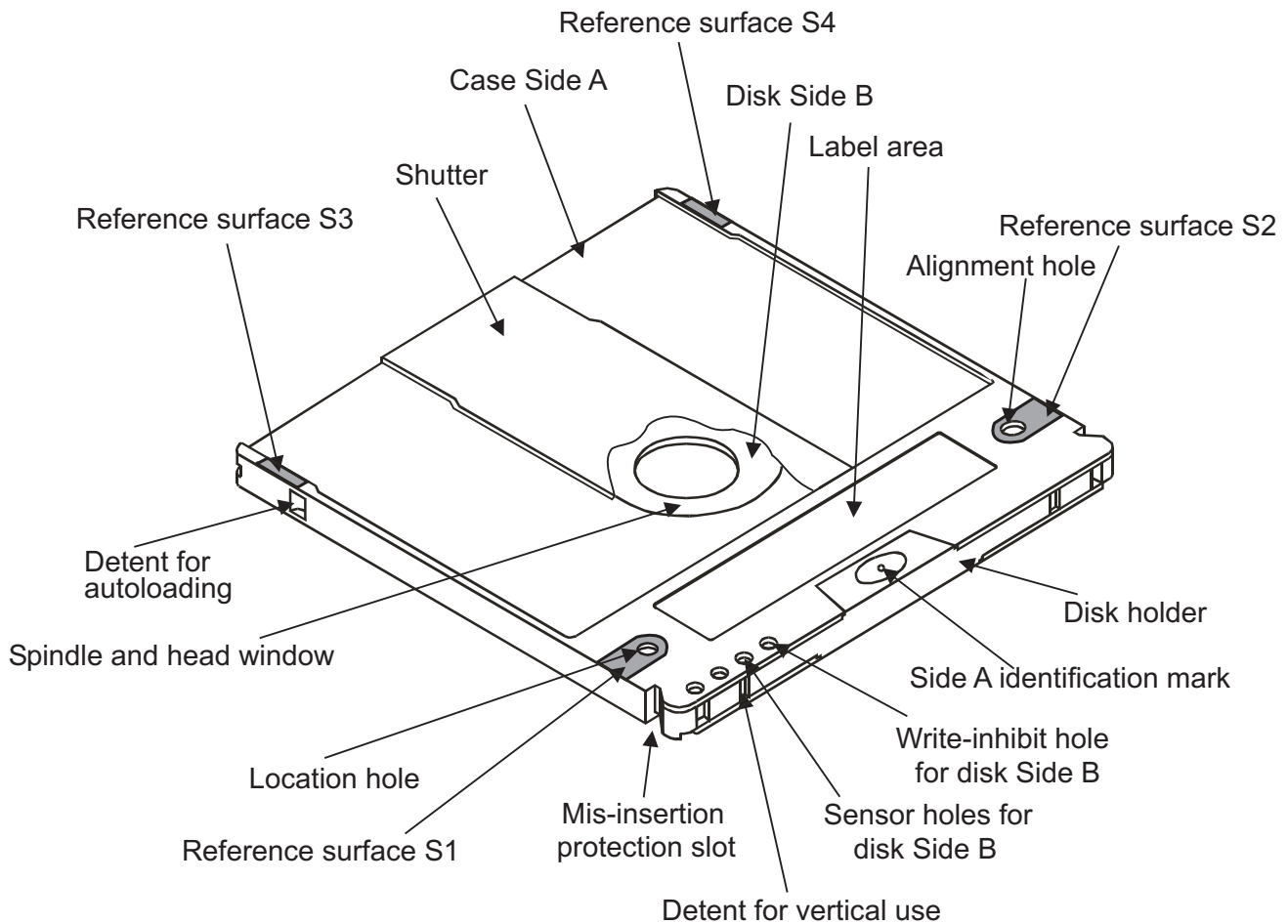

01-0046-A

Figure 4 - General view of the Type 6 and Type 8 cases, seen from Side A

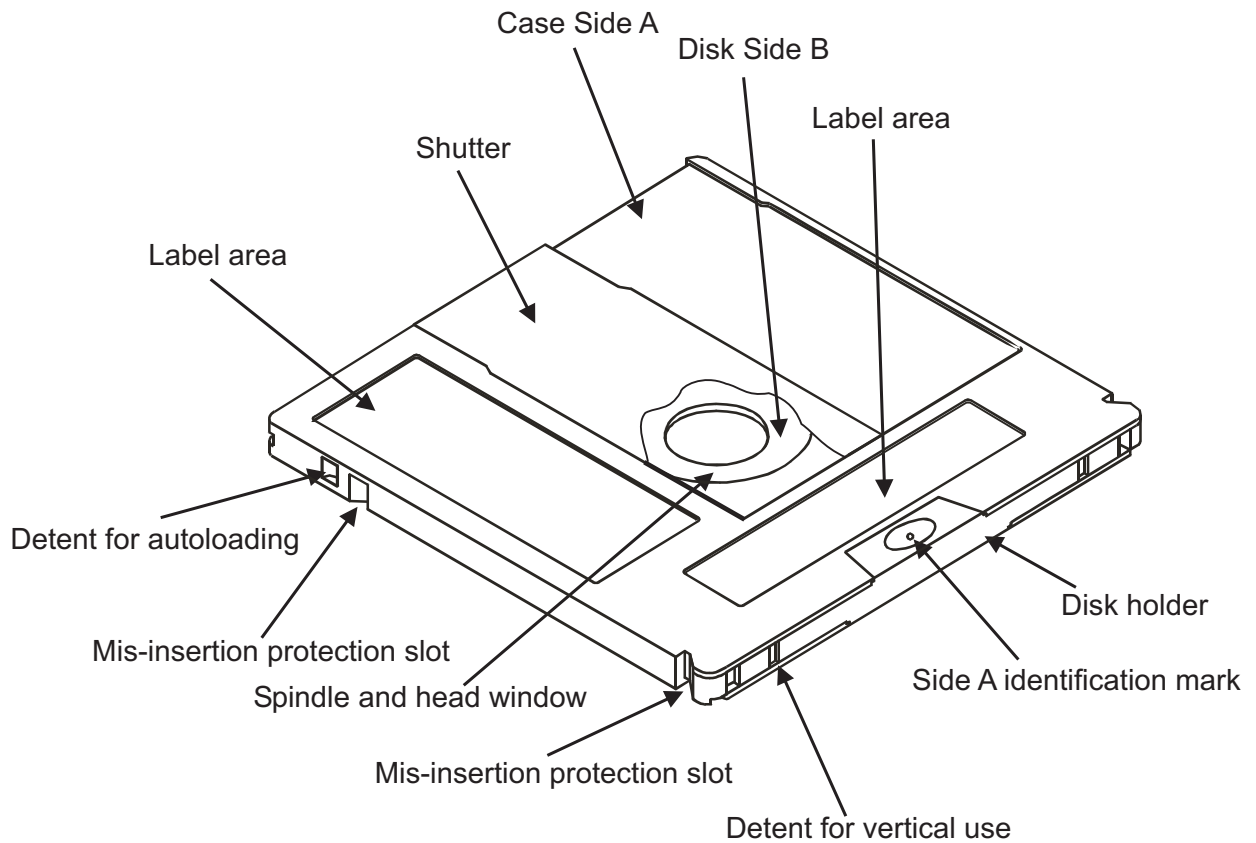

01-0047-A

Figure 5 - General view of the Type 7 and Type 9 cases, seen from Side A

7 General requirements

7.1 Environments

7.1.1 Test environment

The test environment is the environment where the air immediately surrounding the case has the following properties:

Temperature:	23 °C ± 2 °C
Relative humidity:	50 % ± 5 %
Atmospheric pressure:	86 kPa to 106 kPa

No condensation on or in the case or cartridge shall occur. Before testing, the case or cartridge shall be conditioned in this environment for 48 hours minimum.

Unless otherwise stated, all tests and measurements shall be made in this test environment.

7.1.2 Operating environment

The case shall meet all requirements of this Ecma Standard in the specified test environment and provide mechanical interchange over the specified ranges of environmental parameters in the operating environment. When the case according to this Ecma Standard contains a DVD-RAM disk according to Standard ECMA-330, they constitute together a cartridge. This cartridge shall meet the requirements of this clause and provides for data interchange.

The operating environment is the environment where the air immediately surrounding the case or cartridge has the following properties:

Temperature:	5 °C to 60 °C
Relative humidity:	3 % to 85 %
Absolute humidity:	1 g/m ³ to 30 g/m ³
Temperature gradient:	10 °C /h max.
Relative humidity gradient:	10 %/h max.

No condensation on or in the case or cartridge shall occur. If the case or cartridge has been exposed to conditions outside those specified in this clause, it shall be acclimatized in the operating environment for at least 2 h before use.

7.1.3 Storage environment

The storage environment is defined as an environment where the air immediately surrounding the case or cartridge has the following properties.

Temperature:	-10 °C to 50 °C
Relative humidity:	3 % to 85 %
Absolute humidity:	1 g/m ³ to 30 g/m ³
Atmospheric pressure:	75 kPa to 106 kPa
Temperature gradient:	10 °C /h max.
Relative humidity gradient:	10 %/h max.

No condensation on or in the case or cartridge shall occur.

7.1.4 Transportation

This does not specify requirements for transportation; guidance is given in Annex E.

7.2 Temperature shock

The case shall withstand a temperature shock of up to 20°C when inserted into, or removed from, the drive.

7.3 Safety requirement

The case shall satisfy the safety requirements of Standard ECMA-287, when used in the intended manner or in any foreseeable use in an information processing system.

7.4 Flammability

The case shall be made from materials shall be of materials that, if ignited from a match flame, shall not continue to burn in a still carbon dioxide atmosphere.

Section 2 – Dimensional and mechanical characteristics of the case for 120 mm disks

8 Dimensional characteristics

The dimensions of the case shall be referred to three orthogonal Reference Planes X, Y and Z. The case shall be constrained such that four reference surfaces S1 to S4 on Side B of the case lie in Reference Plane Z. The intersection of the three planes defines the centre of the location hole. The centre of the alignment hole shall lie on the intersection of Reference Planes X and Z. Refer to Annex A. A dimension of a feature referenced to one of the planes is the shortest distance from the feature to the plane.

Side A of the Type 1, Type 4 and Type 5 cases are referred to as the three orthogonal Reference Planes X, Y' and Z', where

- Y' is a plane parallel to Reference Plane Y at a nominal distance of 102,0 mm,
- Z' is a plane parallel to Reference Plane Z at a nominal distance of 8,0 mm.

8.1 Dimensions of the Type 1 case

The dimensions of the Type 1 case shall be measured in the test environment (see 7.1.1). The dimensions of the case in an operating environment (see 7.1.2) can be estimated from the dimensions specified in this clause.

8.1.1 Overall dimensions (Figure 6)

The total length of the case shall be

$$L_{101} = 135,5 \text{ mm} \pm 0,4 \text{ mm}$$

At a width

$$L_{103} = 3,6 \text{ mm min}$$

the distance from the top of the case to Reference Plane X shall be

$$L_{102} = 112,5 \text{ mm} \begin{matrix} + 0,3 \text{ mm} \\ - 0,2 \text{ mm} \end{matrix}$$

from the left-hand and right-hand edges of the case.

The distance from the bottom of the case to Reference Plane X shall be

$$L_{104} = 23,0 \text{ mm} \pm 0,2 \text{ mm.}$$

The total width of the case shall be

$$L_{105} = 124,6 \text{ mm} \begin{matrix} + 0,0 \text{ mm} \\ - 0,5 \text{ mm} \end{matrix}$$

The distance from the left-hand side of the case to Reference Plane Y shall be

$$L_{106} = 1133,3 \text{ mm} \begin{matrix} + 0,2 \text{ mm} \\ - 0,4 \text{ mm} \end{matrix}$$

The distance from the right-hand side of the case to Reference Plane Y shall be

$$L_{107} = 113,3 \text{ mm} \begin{matrix} + 0,1 \text{ mm} \\ - 0,3 \text{ mm.} \end{matrix}$$

The two corners of the top shall be rounded off with a radius

$$R_{101} = 4,0 \text{ mm} \pm 0,2 \text{ mm}$$

centred at

$$L_{108} = 4,0 \text{ mm} \pm 0,1 \text{ mm}$$

from the edge of the case and

$$L_{109} = 3,5 \text{ mm} \pm 0,1 \text{ mm}$$

from the top of the case.

The two corners of the bottom shall be rounded off with a radius

$$R_{102} = 4,0 \text{ mm} \pm 0,2 \text{ mm.}$$

In the zones delimited by

$$L_{110} = 6,0 \text{ mm}$$

from the left-hand and right-hand edges of the case, there shall be the continuous guide areas running from the top to Reference Plane X of the case, with a width

$$L_{111} = 0,8 \text{ mm min.}$$

The thickness of the case shall be

$$L_{112} = 8,0 \text{ mm} \begin{array}{l} + 0,2 \text{ mm} \\ - 0,1 \text{ mm.} \end{array}$$

The eight long edges of the case shall be rounded off with a radius

$$R_{103} = 0,5 \text{ mm} \pm 0,1 \text{ mm.}$$

8.1.2 Location hole (Figure 6)

The centre of the location hole shall coincide with the intersection of Reference Planes X, Y and Z.

The diameter of the hole shall be

$$D_{101} = 4,00 \text{ mm} \begin{array}{l} + 0,05 \text{ mm} \\ - 0,00 \text{ mm} \end{array}$$

Its depth shall be

$$L_{113} = 1,2 \text{ mm min.}$$

The room below the location hole shall be free by

$$L_{114} = 5,0 \text{ mm min.}$$

below Reference Plane Z

The diameter of the free room shall be at least equal to D_{101} .

The lead-in edges shall be rounded off with a radius

$$R_{104} = 0,5 \text{ mm} \pm 0,1 \text{ mm.}$$

8.1.3 Alignment hole (Figure 6)

The centre of the alignment hole shall lie on the intersection of the Reference Planes X and Z at a distance

$$L_{115} = 102,0 \text{ mm} \pm 0,2 \text{ mm}$$

from Reference Plane Y.

The alignment hole shall have a substantially rectangular shape. Its dimensions shall be

$$L_{116} = 4,00 \text{ mm} \begin{array}{l} + 0,05 \text{ mm} \\ - 0,00 \text{ mm} \end{array}$$

$$L_{117} = 5,6 \text{ mm} \begin{array}{l} + 0,2 \text{ mm} \\ - 0,00 \text{ mm} \end{array}$$

Its depth shall be equal to L_{113} . The room below the alignment hole shall be free by at least L_{114} . The dimensions of the free room shall be at least L_{116} and L_{117} .

The lead-in edges shall be rounded off with a radius R_{104} .

8.1.4 Reference surfaces (Figure 7)

There shall be four reference surfaces S1, S2, S3 and S4 on Side B of the case.

Surfaces S1 and S2 shall be circular with a diameter

$$D_{102} = 7,0 \text{ mm min.}$$

S1 shall be centred on the location hole, and S2 shall be centred on the alignment hole.

Surfaces S3 and S4 shall be rectangular with dimensions

$$L_{118} = 8,2 \text{ mm max.}$$

$$L_{119} = 110,2 \text{ mm max.}$$

from Reference Plane Y and

$$L_{120} = 87,0 \text{ mm max.}$$

$$L_{121} = 108,0 \text{ mm min.}$$

from Reference Plane X, except in the areas of the detents for autoloading.

8.1.5 Insertion slots (Figure 8)

The case shall have two symmetrical insertion slots.

The bottom of the slots shall be at a distance

$$L_{123} = 60,0 \text{ mm} \pm 0,2 \text{ mm}$$

from Reference Plane X.

The depth measured from the edge of the case shall be

$$L_{124} = 2,0 \text{ mm} \begin{matrix} + 0,2 \text{ mm} \\ - 0,0 \text{ mm.} \end{matrix}$$

The side of the insertion slots parallel to Reference Plane Z shall be at a distance

$$L_{125} = 2,5 \text{ mm} \pm 0,1 \text{ mm}$$

from Reference Plane Z. The width of the insertion slots shall be

$$L_{126} = 3,0 \text{ mm} \begin{matrix} + 0,2 \text{ mm} \\ - 0,0 \text{ mm.} \end{matrix}$$

The slots shall have a lead-in slope defined by

$$L_{127} = 7,0 \text{ mm} \pm 0,2 \text{ mm}$$

from the top of the case and an angle

$$\alpha_{101} = 7,5^\circ \pm 1,0^\circ.$$

8.1.6 Detents (Figure 8)

The case shall have two symmetrical detents intended for autoloading. The detents shall be through Side A and Side B.

The position and dimensions of the detents shall be

$$R_{105} = 0,5 \text{ mm max.}$$

$$L_{128} = 100,5 \text{ mm} \pm 0,3 \text{ mm}$$

$$L_{129} = 93,0 \text{ mm} \pm 0,3 \text{ mm}$$

$$L_{130} = 3,3 \text{ mm} \pm 0,1 \text{ mm}$$

$$L_{131} = 2,5 \text{ mm} \pm 0,1 \text{ mm.}$$

The outside edges of the detents shall be rounded off with a radius

$$R_{106} = 0,5 \text{ mm} \pm 0,1 \text{ mm.}$$

The bottom of the case shall have two symmetrical detents intended for clamping a cartridge in case of vertical use. Their dimensions shall be

$$L_{132} = 3,0 \text{ mm} \pm 0,1 \text{ mm}$$

$$L_{133} = 3,0 \text{ mm} \pm 0,1 \text{ mm}$$

$$L_{134} = 1,0 \text{ mm} \pm 0,1 \text{ mm}$$

The centre of one of these detents shall lie on Reference Plane Y and the centre of the other shall be at a distance

$$L_{135} = 102,0 \text{ mm} \pm 0,3 \text{ mm}$$

from Reference Plane Y. Both centres shall be at a distance

$$L_{136} = 4,0 \text{ mm} \pm 0,1 \text{ mm}$$

from Reference Plane Z.

8.1.7 Gripper slots (Figure 8)

The case shall have two symmetrical gripper slots. The slots shall be through Sides A and B.

Each slot shall have a depth of

$$L_{137} = 3,0 \text{ mm} \begin{array}{l} + 0,3 \text{ mm} \\ - 0,0 \text{ mm} \end{array}$$

from the edge of the case and a width of

$$L_{138} = 4,0 \text{ mm} \begin{array}{l} + 0,3 \text{ mm} \\ - 0,0 \text{ mm} \end{array}$$

The upper edge of the slot shall be at

$$L_{139} = 11,0 \text{ mm} \begin{array}{l} + 0,0 \text{ mm} \\ - 0,3 \text{ mm} \end{array}$$

from Reference Plane X.

The corners of the slot shall be rounded off by a radius

$$R_{107} = 0,5 \text{ mm} \pm 0,2 \text{ mm}.$$

8.1.8 Write-inhibit hole (Figure 9)

The cases for two-sided disks shall have a write-inhibit hole on both Sides A and B. The cases for one-sided disks shall have a write-inhibit hole on Side B only. The write-inhibit hole shall have a device for opening and closing the hole. The hole at the right-hand side of Side B of the case, is the write-inhibit hole for Side A of the disk. The protected side of the disk shall be identified either by an indication on the case or by the fact that the device for Side A of the disk can be operated only from Side A of the case.

When writing and erasing on Side A of the disk are not allowed, the write-inhibit hole shall be open. It shall have a diameter

$$D_{103} = 3,0 \text{ mm min.}$$

The position of its centre shall be specified on Side B of the case by

$$L_{140} = 18,5 \text{ mm} \pm 0,2 \text{ mm}$$

$$L_{141} = 9,0 \text{ mm} \pm 0,2 \text{ mm}$$

The hole shall extend below Reference Plane Z by

$$L_{142} = 5,0 \text{ mm min.}$$

with a diameter equal at least to D_{103} .

When writing and erasing of the disk are allowed, the write-inhibit hole shall be closed by the write protect device.

The write protect device shall not be recessed from Reference Plane Z by more than 0,3 mm.

8.1.9 Sensor holes (Figure 9)

The case shall have three sensor holes on Side B. The set of holes on Side B of the case, A1, A2 and A3 pertains to Side A of the disk. The holes shall have a diameter of

$$D_{104} = 3,0 \text{ mm min.}$$

The positions of their centres shall be specified by L_{140} and

$$L_{144} = 7,5 \text{ mm} \pm 0,2 \text{ mm}$$

$$L_{145} = 3,5 \text{ mm} \pm 0,2 \text{ mm}$$

$$L_{146} = 2,0 \text{ mm} \pm 0,2 \text{ mm.}$$

The room below the holes shall be free by

$$L_{147} = 5,0 \text{ mm min.}$$

from Reference Plane Z.

The diameter of the free room shall be at least equal to D_{104} . The holes shall be permitted to extend through Side A.

When a hole for Side A of the disk is closed, the closure shall not be recessed from Reference Plane Z by more than 0,3 mm.

Side A of the case shall have corresponding sensor holes B1, B2 and B3 with the diameter D_{104} .

The functions identified by the states of the sensor holes are specified in Table 1.

Table 1 - States of the sensor holes

Sensor hole	Function		State	
	Closed	Open	Case for a two-sided disk	Case for a one-sided disk
A1	The original disk is in the case	Not permitted	Closed	Closed
A2	Active side	Not permitted	Closed	Closed
A3	Reserved for future standardization		Closed	Closed
B1	The original disk is in the case	Not permitted	Closed	Closed
B2	Active side	Non active side	Closed	Open
B3	Reserved for future standardization		Closed	Closed

8.1.10 Sensing areas (Figure 9)

The case shall have two sensing areas on Side B used by drives for the detection of a cartridge. The first area shall be limited by Reference Planes X and Y, the bottom and the right-hand side of the case. The second area shall be limited by Reference Plane X, a plane parallel to Reference Plane Y at a distance equal to L_{115} , the bottom and the left-hand side of the case. These areas may be recessed from Reference Plane Z by 0,3 mm max., except for the reference surfaces S1 and S2, the gripper slots and the sensor holes.

8.1.11 Spindle and head window (Figure 10)

The dimensions of the window shall be referenced to a centreline, located at a distance

$$L_{150} = 51,0 \text{ mm} \pm 0,1 \text{ mm}$$

from Reference Plane Y. The width of the window from the top of the case to

$$L_{151} = 50,0 \text{ mm max.}$$

shall be

$$L_{152} = 19,5 \text{ mm} \begin{matrix} + 0,2 \text{ mm} \\ - 0,00 \text{ mm} \end{matrix}$$

and

$$L_{153} = 19,5 \text{ mm} \begin{matrix} + 0,2 \text{ mm} \\ - 0,00 \text{ mm} \end{matrix}$$

The top of the window shall be specified by

$$R_{108} = 60,7 \text{ mm min.}$$

originating from the intersection of L_{150} and

$$L_{154} = 40,0 \text{ mm} \pm 0,1 \text{ mm.}$$

The width of the window from L_{151} to L_{154} shall be given by

$$L_{155} = 17,0 \text{ mm min.}$$

and

$$L_{156} = 17,0 \text{ mm min.}$$

The bottom of the window shall be the arc of the semi-circle that smoothly joins the sides of the window, specified by a radius

$$R_{109} = 17,0 \text{ mm min.}$$

and its centre shall be defined by the intersection of L_{150} and L_{154} .

The area bounded by R_{108} and top of the case shall be recessed from Reference Plane Z by

$$L_{157} = 2,55 \text{ mm min.}$$

over the width of the window.

8.1.12 Shutter shape (Figure 11)

The case shall have a spring-loaded shutter completely covering the spindle and the head window when the case is not inside a drive. The shutter shall be free to slide in a recessed area of the case. The shutter shall not protrude beyond Reference Planes Z or Z' by more than 0,15 mm.

When introduced into a drive, the shutter shall be moved so as to uncover the spindle and the head windows. It shall have a pair of guide edges against which the shutter opening mechanism of the drive can act to open the shutter. The shutter can be shifted right or left.

Both guide edges shall be located at

$$L_{158} = 112,0 \text{ mm} \begin{matrix} + 0,2 \text{ mm} \\ - 0,4 \text{ mm} \end{matrix}$$

from Reference Plane X.

When the shutter is closed, the right-hand opener edge shall be at

$$L_{159} = 38,0 \text{ mm} \pm 0,4 \text{ mm}$$

and the left-hand opener edge shall be at

$$L_{160} = 64,0 \text{ mm} \pm 0,4 \text{ mm}$$

from Reference Plane Y.

The depth of each opener edge shall be at

$$L_{161} = 3,0 \text{ mm} \begin{matrix} + 0,2 \text{ mm} \\ - 0,0 \text{ mm} \end{matrix}$$

from L_{158} and the top shall be rounded off with a radius

$$R_{110} = 0,5 \text{ mm max.}$$

The length of the guide edges measured from the corresponding opener edge shall be

$$L_{162} = 7,0 \text{ mm min.}$$

The intersection of the guide edges and the opener edges shall be rounded off with a radius

$$R_{111} = 0,5 \text{ mm max.}$$

Other corners of the guide and opener edges shall be rounded off with a radius

$$R_{112} = 1,0 \text{ mm max.}$$

8.1.13 Path for shutter opener (Figures 12 and 13)

When the shutter is moved rightwards until the left-hand opener edge is at a distance

$$L_{163} = 26,5 \text{ mm}$$

from Reference Plane Y, the windows shall be open over

$$L_{164} = 16,5 \text{ mm min.}$$

from L_{150} and over an arc of

$$R_{113} = 17,0 \text{ mm min.}$$

originating at the intersection of L_{150} and L_{154} .

The left-hand opener edge shall be at

$$L_{165} = 26,0 \text{ mm max.}$$

from Reference Plane Y, when the shutter is in its right-hand end position.

When the corresponding the position of the right-hand opener edge is

$$L_{166} = 75,5 \text{ mm,}$$

the windows shall be open at L_{164} from L_{150} and with a radius R_{113} originating at the intersection of L_{150} and L_{154} .

The position of the right-hand opener edge shall be

$$L_{167} = 76,0 \text{ mm min.}$$

when the shutter is in its left-hand end position.

8.1.14 Label areas (Figure 14)

The case shall have three label areas on Side A and Side B and on the bottom side, with the following dimensions.

On Sides A and B

$$L_{168} = 10,0 \text{ mm} \pm 0,2 \text{ mm}$$

$$L_{169} = 13,0 \text{ mm} \pm 0,2 \text{ mm}$$

$$L_{170} = 76,0 \text{ mm} \pm 0,3 \text{ mm}$$

$$R_{114} = 2,0 \text{ mm} \pm 0,2 \text{ mm}$$

On the bottom side

$$L_{171} = 13,0 \text{ mm} \pm 0,2 \text{ mm}$$

$$L_{172} = 76,0 \text{ mm} \pm 0,3 \text{ mm}$$

$$L_{173} = 5,0 \text{ mm} \pm 0,2 \text{ mm}$$

$$L_{174} = 97,0 \text{ mm} \pm 0,3 \text{ mm}$$

$$L_{175} = 1,0 \text{ mm} \pm 0,2 \text{ mm}$$

$$L_{176} = 6,0 \text{ mm} \pm 0,2 \text{ mm.}$$

The label area shall be recessed by 0,2 mm min. on all three sides.

8.1.15 Identification marks for Sides A and B (Figure 15)

Side A and Side B shall be identified by an identification mark provided on a concave part on the right-hand side of Side A and Side B, respectively. On Side A, this concave part presents one small round projection, on Side B two such projections are provided. The position and dimensions of these identification marks shall be as follows.

Side A

$$R_{115} = 0,5 \text{ mm} \begin{array}{l} + 0,1 \text{ mm} \\ - 0,0 \text{ mm} \end{array}$$

$$R_{116} = 18,0 \text{ mm} \pm 1,0 \text{ mm}$$

$$L_{178} = 0,5 \text{ mm} \begin{array}{l} + 0,1 \text{ mm} \\ - 0,0 \text{ mm} \end{array}$$

$$L_{179} = 7,0 \text{ mm} \pm 0,3 \text{ mm}$$

$$L_{180} = 5,0 \text{ mm} \pm 0,3 \text{ mm}$$

$$L_{181} = 0,6 \text{ mm} \begin{array}{l} + 0,1 \text{ mm} \\ - 0,0 \text{ mm} \end{array}$$

Side B

$$R_{115} = 0,5 \text{ mm} \begin{array}{l} + 0,1 \text{ mm} \\ - 0,0 \text{ mm} \end{array}$$

$$R_{116} = 18,0 \text{ mm} \pm 1,0 \text{ mm}$$

$$L_{178} = 0,5 \text{ mm} \begin{array}{l} + 0,1 \text{ mm} \\ - 0,0 \text{ mm} \end{array}$$

$$L_{179} = 7,0 \text{ mm} \pm 0,3 \text{ mm}$$

$$L_{180} = 5,0 \text{ mm} \pm 0,3 \text{ mm}$$

$$L_{181} = 0,6 \text{ mm} \begin{array}{l} + 0,1 \text{ mm} \\ - 0,0 \text{ mm} \end{array}$$

$$L_{182} = 3,2 \text{ mm} \pm 0,3 \text{ mm}.$$

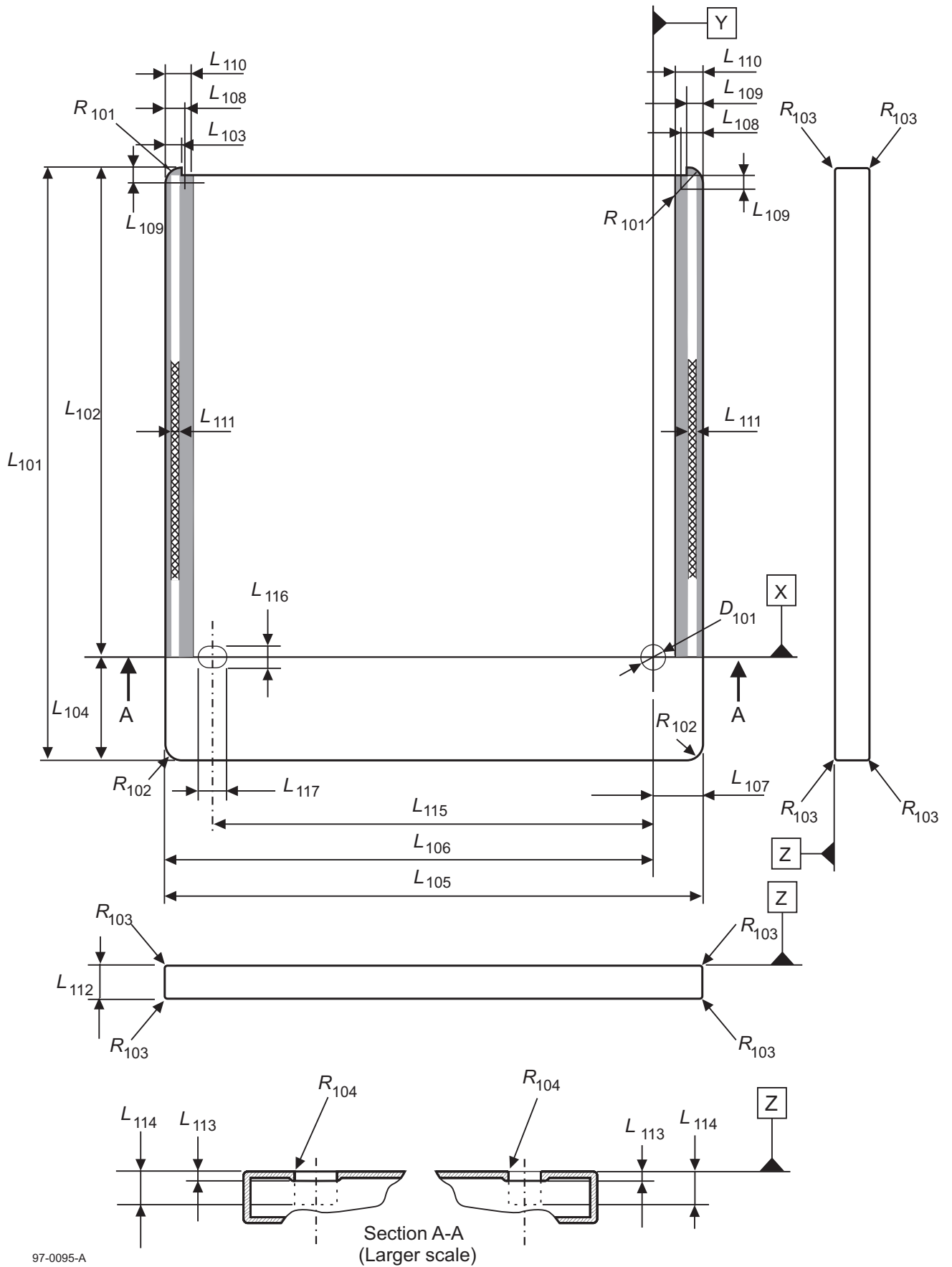
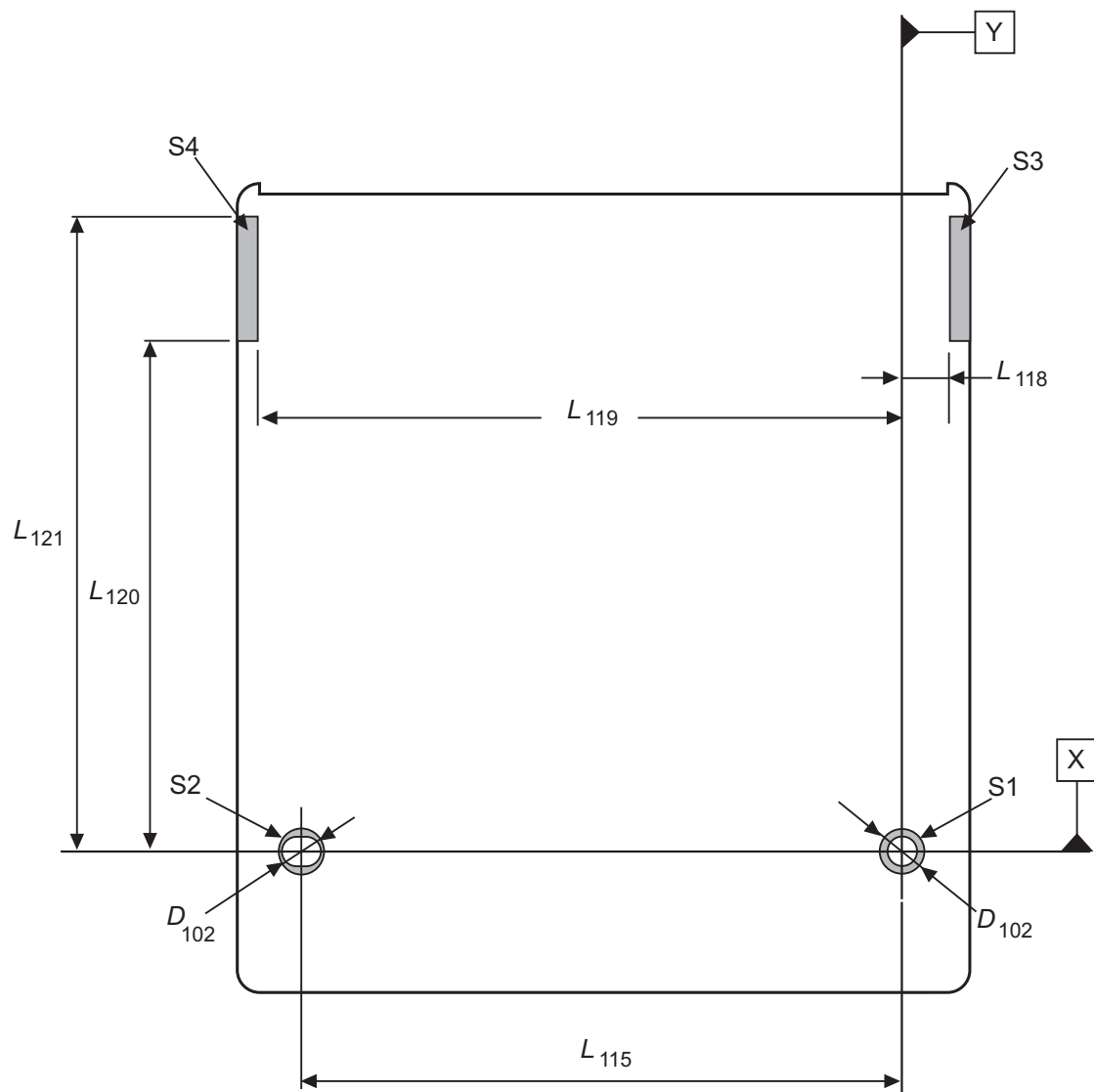
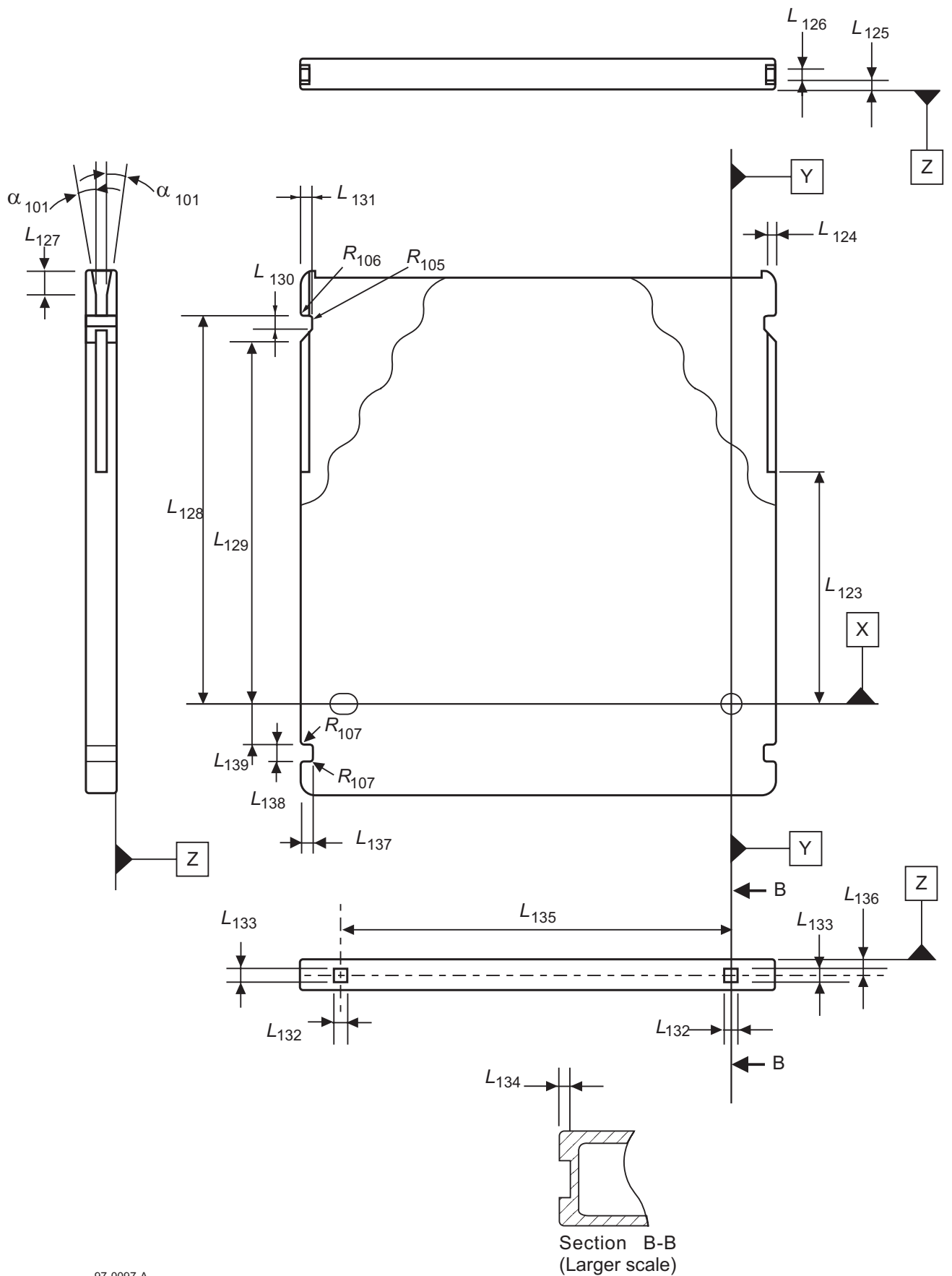

Figure 6 - Overall dimensions



97-0096-A

Figure 7 - Reference surfaces



97-0097-A

Figure 8 - Insertion slots, detents and gripper slots

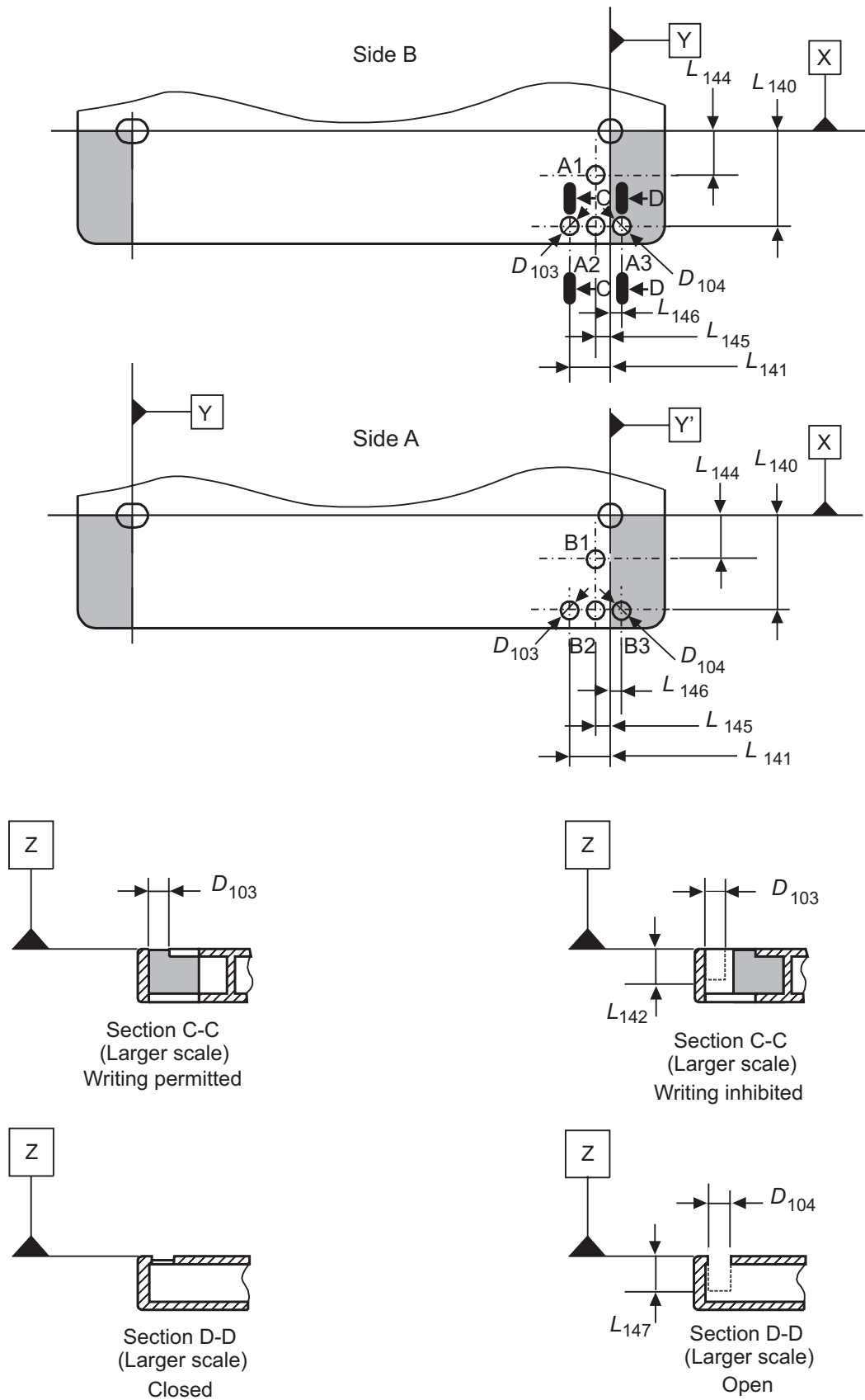

01-0090-A

Figure 9 - Write-inhibit hole, sensor holes and sensing areas

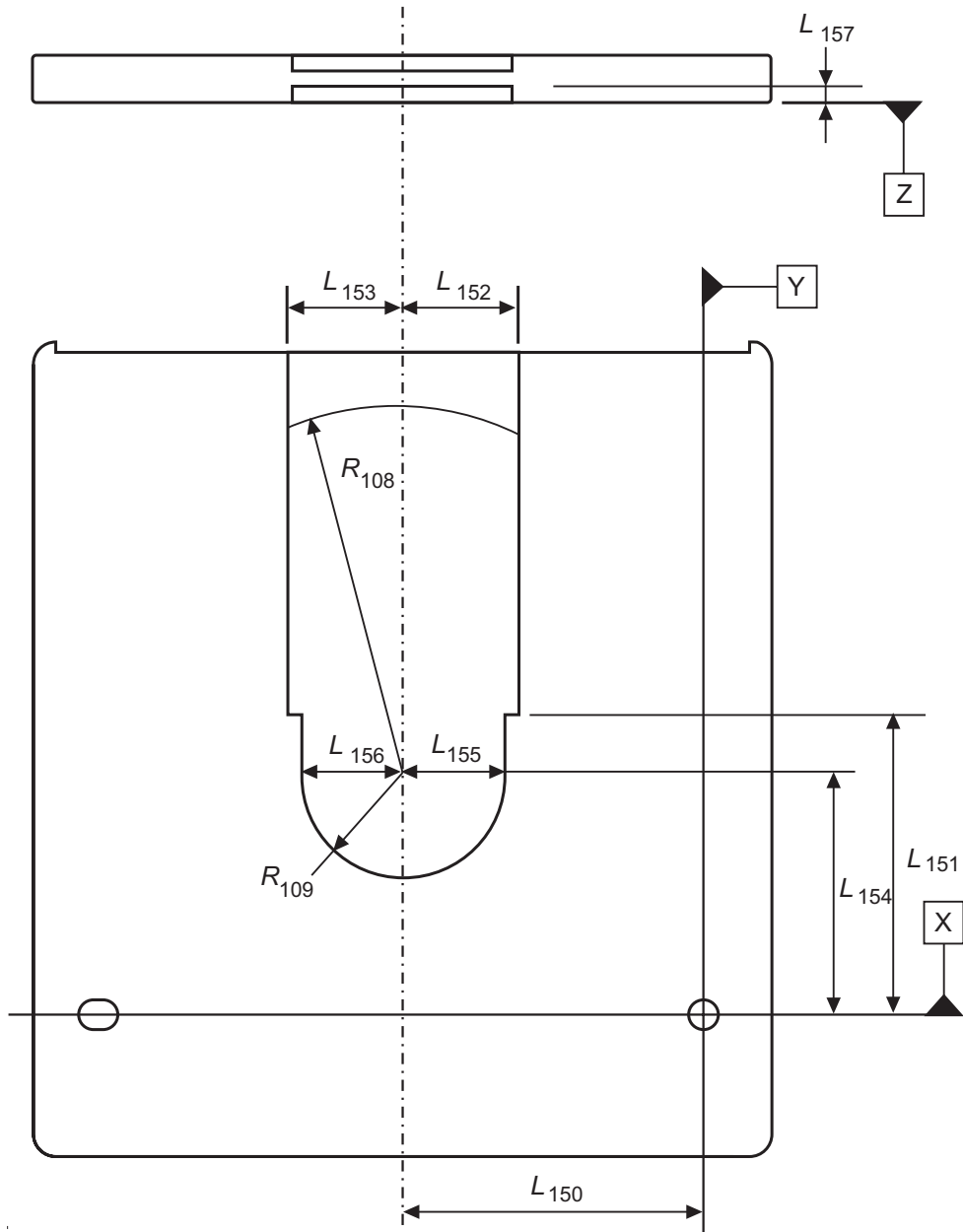

97-0099-A

Figure 10 - Spindle and head window

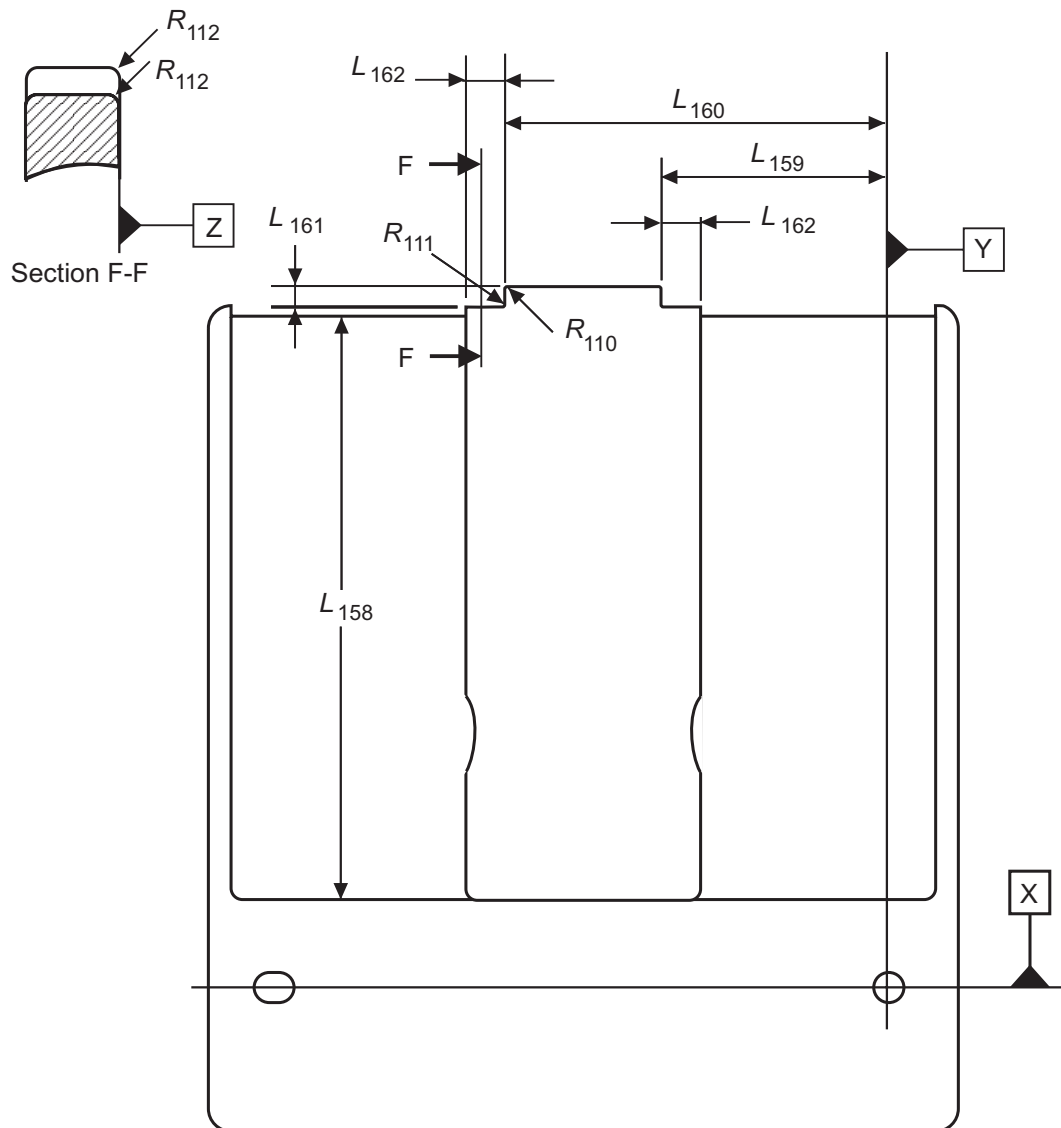

97-0100-A

Figure 11 - Shape of the shutter

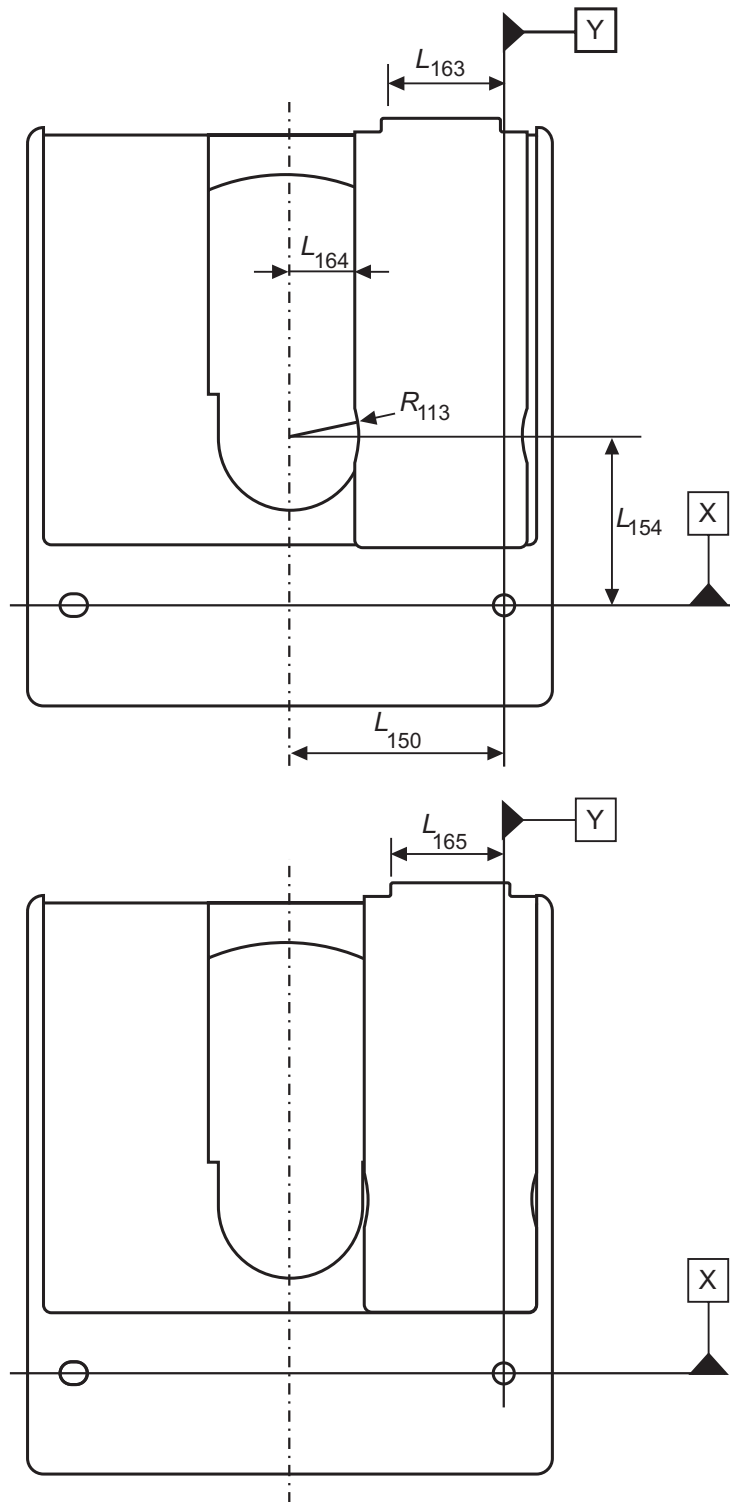

97-0101-A

*Figure 12 - Shutter in just right-hand open position (top view)
and maximum right-hand open position (bottom view)*

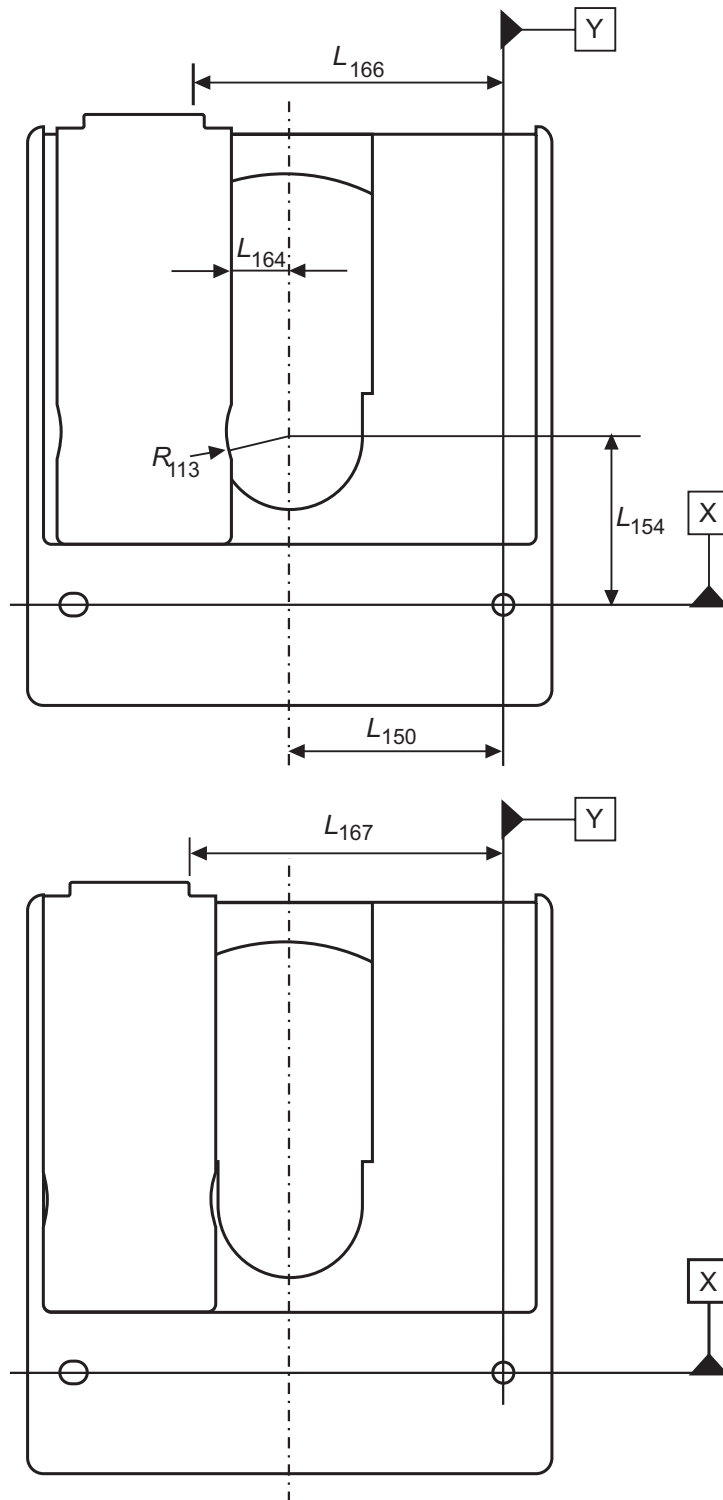

97-0102-A

*Figure 13 - Shutter in just left-hand open position (top view)
and maximum left-hand open position (bottom view)*

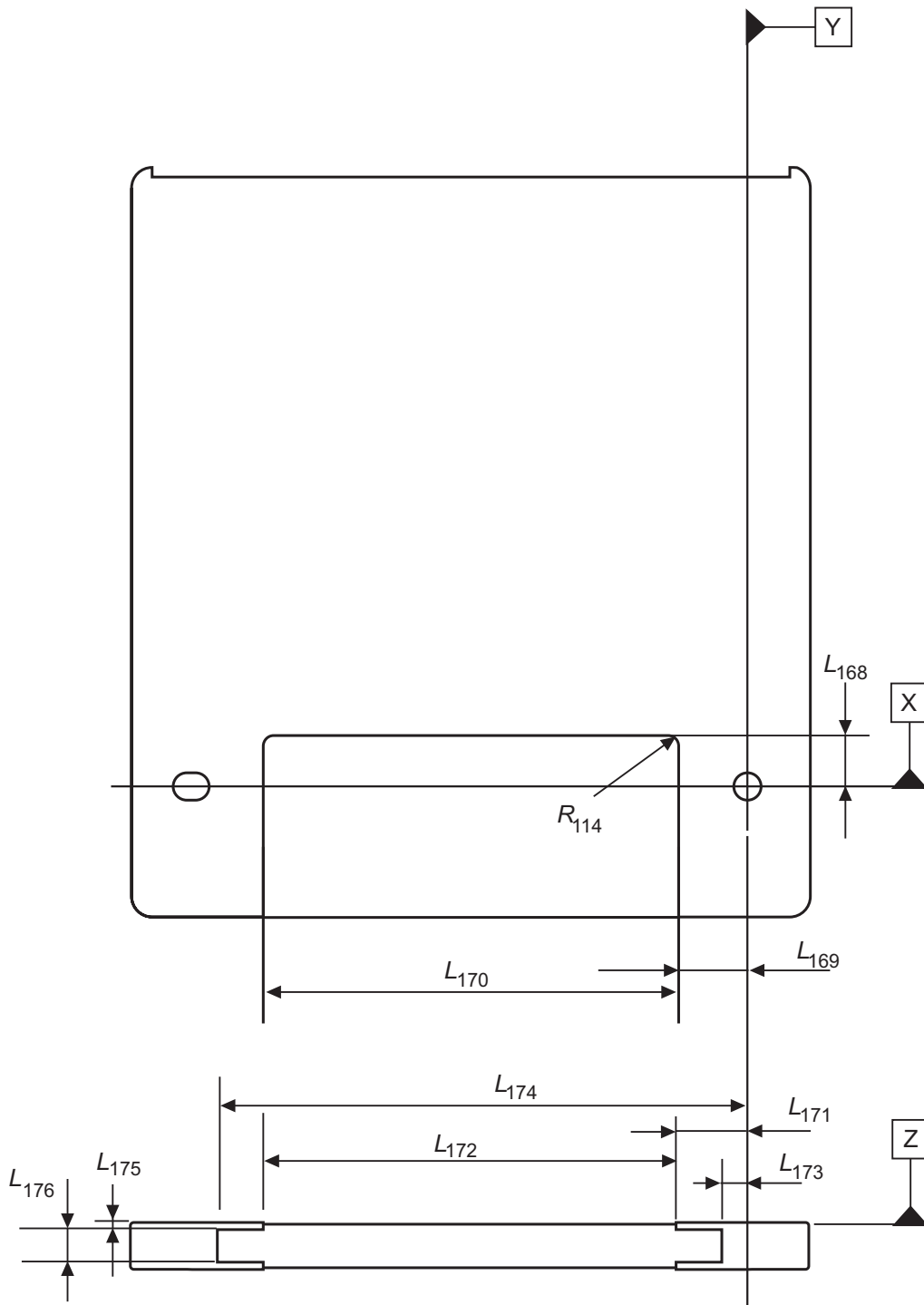

97-0103-A

Figure 14 - Label areas

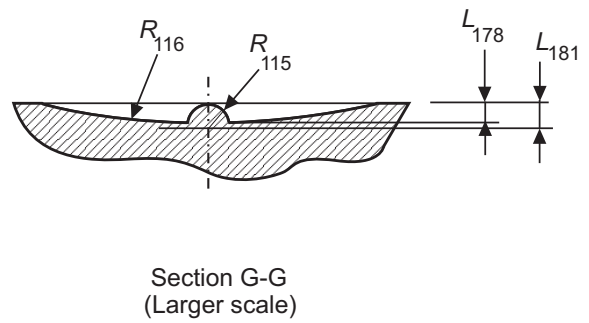
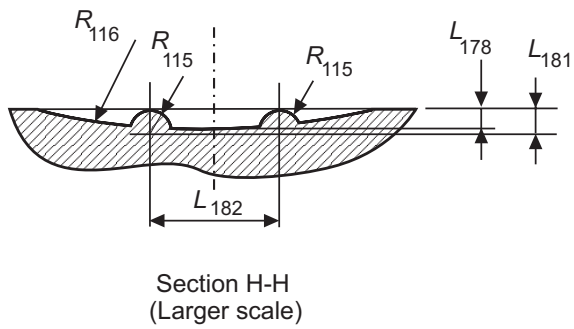
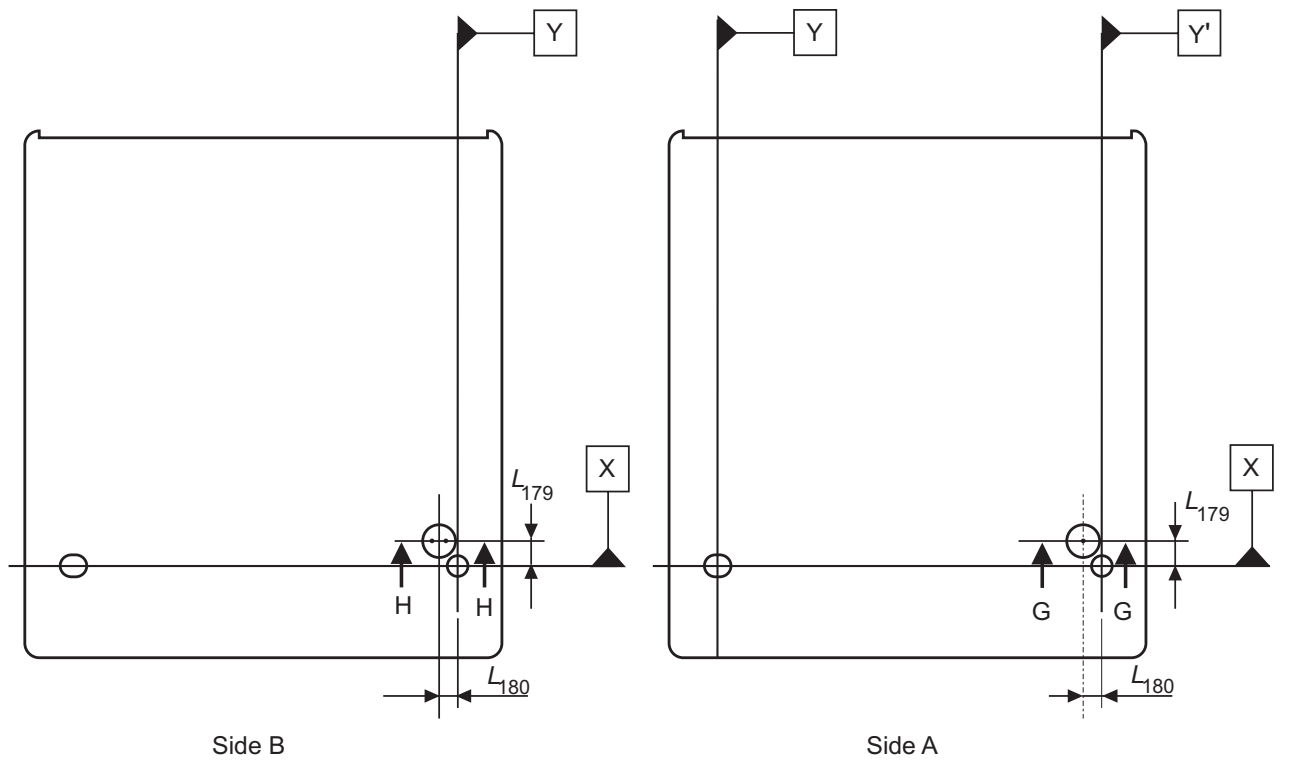

97-0104-A

Figure 15 - Identification marks of Side A and B

8.2 Dimensions of the Type 2 case

The dimensions of the Type 2 case shall be measured in the test environment (see 7.1.1). The dimensions of the case in an operating environment (see 7.1.2) can be estimated from the dimensions specified in this clause.

8.2.1 Overall dimensions (Figure 16)

The total length of the case shall be

$$L_{201} = 135,5 \text{ mm} \pm 0,4 \text{ mm.}$$

At a width

$$L_{203} = 3,6 \text{ mm min.}$$

the distance from the top of the case to Reference Plane X shall be

$$L_{202} = 112,5 \text{ mm} \begin{matrix} + 0,3 \text{ mm} \\ - 0,2 \text{ mm} \end{matrix}$$

from the left-hand and right-hand edges of the case.

The distance from the bottom of the case to Reference Plane X shall be

$$L_{204} = 23,0 \text{ mm} \pm 0,2 \text{ mm.}$$

The total width of the case shall be

$$L_{205} = 124,6 \text{ mm} \begin{matrix} + 0,0 \text{ mm} \\ - 0,5 \text{ mm} \end{matrix}$$

The distance from the left-hand side of the case to Reference Plane Y shall be

$$L_{206} = 113,3 \text{ mm} \begin{matrix} + 0,2 \text{ mm} \\ - 0,4 \text{ mm} \end{matrix}$$

The distance from the right-hand side of the case to Reference Plane Y shall be

$$L_{207} = 11,3 \text{ mm} \begin{matrix} + 0,1 \text{ mm} \\ - 0,3 \text{ mm} \end{matrix}$$

The two corners of the top shall be rounded off with a radius

$$R_{201} = 4,0 \text{ mm} \pm 0,2 \text{ mm}$$

centred at

$$L_{208} = 4,0 \text{ mm} \pm 0,1 \text{ mm}$$

from the edge of the case and

$$L_{209} = 3,5 \text{ mm} \pm 0,1 \text{ mm}$$

from the top of the case.

The two corners of the bottom shall be rounded off with a radius

$$R_{202} = 4,0 \text{ mm} \pm 0,2 \text{ mm.}$$

In the zones delimited by

$$L_{210} = 6,0 \text{ mm}$$

from the left-hand and right-hand edges of the case, there shall be the continuous guide areas running from the top to Reference Plane X of the case, with a width

$$L_{211} = 0,8 \text{ mm min.}$$

the thickness of the case shall be

$$L_{212} = 8,0 \text{ mm} \begin{array}{l} + 0,2 \text{ mm} \\ - 0,1 \text{ mm} \end{array}$$

The eight long edges of the case shall be rounded off with a radius

$$R_{203} = 0,5 \text{ mm} \pm 0,1 \text{ mm.}$$

L_{210} and L_{211} shall be defined on Side A as well as Side B.

8.2.2 Location hole (Figure 16)

The centre of the location hole shall coincide with the intersection of Reference Planes X, Y and Z.

The diameter of the hole shall be

$$D_{201} = 4,00 \text{ mm} \begin{array}{l} + 0,05 \text{ mm} \\ - 0,00 \text{ mm} \end{array}$$

Its depth shall be

$$L_{213} = 1,2 \text{ mm min.}$$

The room below the location hole shall be free by

$$L_{214} = 5,0 \text{ mm min.}$$

from Reference Plane Z

The diameter of the free room shall be at least equal to D_{201} .

The lead-in edges shall be rounded off with a radius

$$R_{204} = 0,5 \text{ mm} \pm 0,1 \text{ mm.}$$

8.2.3 Alignment hole (Figure 16)

The centre of the alignment hole shall lie on the intersection of the Reference Planes X and Z at a distance

$$L_{215} = 102,0 \text{ mm} \pm 0,2 \text{ mm}$$

from Reference Plane Y.

The alignment hole shall have a substantially rectangular shape. Its dimensions shall be

$$L_{216} = 4,00 \text{ mm} \begin{array}{l} + 0,05 \text{ mm} \\ - 0,00 \text{ mm} \end{array}$$

$$L_{217} = 5,6 \text{ mm} \begin{array}{l} + 0,2 \text{ mm} \\ - 0,0 \text{ mm} \end{array}$$

Its depth shall be equal to L_{213} . The room below the alignment hole shall be free by at least L_{214} . The dimensions of the free room shall be at least L_{216} and L_{217} .

The lead-in edges shall be rounded off with a radius R_{204} .

8.2.4 Reference surfaces (Figure 17)

There shall be four reference surfaces S1, S2, S3 and S4 on Side B of the case.

Surfaces S1 and S2 shall be circular with a diameter

$$D_{202} = 7,0 \text{ mm min.}$$

S1 shall be centred on the location hole, and S2 shall be centred on the alignment hole.

Surfaces S3 and S4 shall be rectangular with dimensions

$$L_{218} = 8,2 \text{ mm max.}$$

$$L_{219} = 110,2 \text{ mm max.}$$

from Reference Plane Y and

$$L_{220} = 87,0 \text{ mm max.}$$

$$L_{221} = 108,0 \text{ mm min.}$$

from Reference Plane X, except in the areas of the detents for autoloading.

8.2.5 Insertion slot (Figure 18)

The case shall have an insertion slot on its right-hand side.

The bottom of the slots shall be at a distance

$$L_{223} = 60,0 \text{ mm} \pm 0,2 \text{ mm}$$

from Reference Plane X.

The depth measured from the edge of the case shall be

$$L_{224} = 2,0 \text{ mm} \begin{matrix} + 0,2 \text{ mm} \\ - 0,0 \text{ mm} \end{matrix}$$

The side of the insertion slot parallel to Reference Plane Z shall be at a distance

$$L_{225} = 2,5 \text{ mm} \pm 0,1 \text{ mm}$$

from Reference Plane Z. The width of the insertion slot shall be

$$L_{226} = 3,0 \text{ mm} \begin{matrix} + 0,2 \text{ mm} \\ - 0,0 \text{ mm} \end{matrix}$$

The slots shall have a lead-in slope defined by

$$L_{227} = 7,0 \text{ mm} \pm 0,2 \text{ mm}$$

from the top of the case and an angle

$$\alpha_{201} = 7,5^\circ \pm 1,0^\circ \alpha.$$

8.2.6 Detents (Figure 18)

The case shall have two symmetrical detents intended for autoloading. The detents shall not extend through Side A.

The position and dimensions of the detents shall be

$$R_{205} = 0,5 \text{ mm max.}$$

$$L_{228} = 100,5 \text{ mm} \pm 0,3 \text{ mm}$$

$$L_{229} = 93,0 \text{ mm} \pm 0,3 \text{ mm}$$

$$L_{230} = 3,3 \text{ mm} \pm 0,1 \text{ mm}$$

$$L_{231} = 2,5 \text{ mm} \pm 0,1 \text{ mm.}$$

The outside edges of the detents shall be rounded off with a radius

$$R_{206} = 0,5 \text{ mm} \pm 0,1 \text{ mm.}$$

The depth of the detents shall be

$$L_{232} = 6,5 \text{ mm} \pm 0,2 \text{ mm.}$$

The bottom of the case shall have two symmetrical detents intended for clamping a cartridge in case of vertical use. Their dimensions shall be

$$L_{233} = 3,0 \text{ mm} \pm 0,1 \text{ mm}$$

$$L_{234} = 3,0 \text{ mm} \pm 0,1 \text{ mm}$$

$$L_{235} = 1,0 \text{ mm} \pm 0,1 \text{ mm}$$

The centre of one of these detents shall lie on Reference Plane Y and the centre of the other shall be at a distance

$$L_{236} = 102,0 \text{ mm} \pm 0,3 \text{ mm}$$

from Reference Plane Y. Both centres shall be at a distance

$$L_{237} = 4,0 \text{ mm} \pm 0,1 \text{ mm}$$

from Reference Plane Z.

8.2.7 Gripper slots (Figure 18)

The case shall have two symmetrical gripper slots. The slots shall not extend through Side A.

Each slot shall have a depth of

$$L_{238} = 3,0 \text{ mm} \begin{array}{l} + 0,3 \text{ mm} \\ - 0,0 \text{ mm} \end{array}$$

from the edge of the case and a width of

$$L_{239} = 4,0 \text{ mm} \begin{array}{l} + 0,3 \text{ mm} \\ - 0,0 \text{ mm} \end{array}$$

The upper edge of the slot shall be at

$$L_{240} = 11,0 \text{ mm} \begin{array}{l} + 0,0 \text{ mm} \\ - 0,3 \text{ mm} \end{array}$$

from Reference Plane X.

The corners of the slot shall be rounded off by a radius

$$R_{207} = 0,5 \text{ mm} \pm 0,2 \text{ mm}.$$

The depth of the gripper slots shall be

$$L_{241} = 6,5 \text{ mm} \pm 0,2 \text{ mm}.$$

8.2.8 Write-inhibit hole (Figure 19)

The case shall have a write-inhibit hole on Side B. The write-inhibit hole shall have a device for opening and closing the hole.

When writing and erasing on Side A of the disk are not allowed, the write-inhibit hole shall be open. It shall have a diameter

$$D_{203} = 3,0 \text{ mm min.}$$

The position of its centre shall be specified by

$$L_{242} = 18,5 \text{ mm} \pm 0,2 \text{ mm}$$

$$L_{243} = 9,0 \text{ mm} \pm 0,2 \text{ mm}$$

on Side B of the case.

The hole shall extend below Reference Plane Z by

$$L_{244} = 5,0 \text{ mm min.}$$

with a diameter equal at least to D_{203} .

When writing and erasing of the disk are allowed, the write-inhibit hole shall be closed by the write protect device.

The write protect device shall not be recessed from Reference Plane Z by more than 0,3 mm.

8.2.9 Sensor holes (Figure 19)

The case shall have three sensor holes on Side B. The set of holes on Side B of the case, A1, A2 and A3 pertains to Side A of the disk. The holes shall have a diameter of

$$D_{204} = 3,0 \text{ mm min.}$$

and the positions of their centres shall be specified by L_{242} and

$$L_{246} = 7,5 \text{ mm} \pm 0,2 \text{ mm}$$

$$L_{247} = 3,5 \text{ mm} \pm 0,2 \text{ mm}$$

$$L_{248} = 2,0 \text{ mm} \pm 0,2 \text{ mm.}$$

The room below the holes shall be free up to

$$L_{249} = 5,0 \text{ mm min.}$$

above Reference Plane Z.

The diameter of the free room shall be at least equal to D_{204} . The holes shall be permitted to extend through Side A.

When a hole for Side A of the disk is closed, the closure shall not be recessed from Reference Plane Z by more than 0,3 mm.

The sensor hole A1 shall indicate whether a disk has been taken out once or not. Originally, the sensor hole A1 shall be closed, and once a disk has been taken out of the case, this hole shall be opened and never closed again.

The functions identified by the states of the sensor holes are specified in Table 2.

Table 2 - States of the sensor holes

Sensor hole	Function		State
	Closed	Open	
A1	The original disk is in the case	The original disk has been taken out, or a disk has been put in	Closed / Open
A2	Active side	Not permitted	Closed
A3	Reserved for future standardization		Closed

8.2.10 Sensing areas (Figure 19)

The case shall have two sensing areas on Side B used by drives for the detection of a cartridge. The first area shall be limited by Reference Planes X and Y, the bottom and the right-hand side of the case. The second area shall be limited by Reference Plane X, a plane parallel to Reference Plane Y at a distance equal to L_{215} , the bottom and the left-hand side of the case. These areas may be recessed from Reference Plane Z by 0,3 mm max., except for the reference surfaces S1 and S2, the gripper slots and the sensor holes.

8.2.11 Spindle and head window (Figure 20)

The dimensions of the window shall be referenced to a centreline, located at a distance

$$L_{252} = 51,0 \text{ mm} \pm 0,1 \text{ mm}$$

from Reference Plane Y. The width of the window from the top of the case to

$$L_{253} = 50,0 \text{ mm max.}$$

shall be

$$L_{254} = 19,5 \text{ mm} \begin{matrix} + 0,2 \text{ mm} \\ - 0,0 \text{ mm} \end{matrix}$$

and

$$L_{255} = 19,5 \text{ mm} \begin{array}{l} + 0,2 \text{ mm} \\ - 0,0 \text{ mm.} \end{array}$$

The top of the window shall be specified by

$$R_{208} = 60,7 \text{ mm min.}$$

originating from the intersection of L_{250} and

$$L_{256} = 40,0 \text{ mm} \pm 0,1 \text{ mm.}$$

The width of the window from L_{253} to L_{256} shall be given by

$$L_{257} = 17,0 \text{ mm min.}$$

and

$$L_{258} = 17,0 \text{ mm min.}$$

The bottom of the window shall be the arc of the semi-circle that smoothly joins the sides of the window, specified by a radius

$$R_{209} = 17,0 \text{ mm min.}$$

Its centre shall be defined by the intersection of L_{252} and L_{256} .

The area bounded by R_{208} and top of the case shall be recessed from Reference Plane Z by

$$L_{259} = 2,55 \text{ mm min.}$$

$$L_{260} = 5,65 \text{ mm max.}$$

over the width of the window.

8.2.12 Shutter shape (Figure 21)

The case shall have a spring-loaded shutter completely covering the spindle and head window when the case is not inside a drive. The shutter shall be free to slide in a recessed area of the case. The shutter shall not protrude beyond Reference Planes Z or the surface of Side A by more than 0,15 mm.

When introduced into a drive, the shutter shall be moved so as to uncover the spindle and head window. It shall have a pair of guide edges against which the shutter opening mechanism of the drive can act to open the shutter. The shutter can be shifted right or left.

Both guide edges shall be located at

$$L_{261} = 112,0 \text{ mm} \begin{array}{l} + 0,2 \text{ mm} \\ - 0,4 \text{ mm.} \end{array}$$

from Reference Plane X.

When the shutter is closed, the right-hand opener edge shall be at

$$L_{262} = 38,0 \text{ mm} \pm 0,4 \text{ mm}$$

and the left-hand opener edge shall be at

$$L_{263} = 64,0 \text{ mm} \pm 0,4 \text{ mm}$$

from Reference Plane Y.

The depth of each opener edge shall be at

$$L_{264} = 3,0 \text{ mm} \begin{array}{l} + 0,2 \text{ mm} \\ - 0,0 \text{ mm} \end{array}$$

from L_{261} and the top shall be rounded off with a radius

$$R_{210} = 0,5 \text{ mm max.}$$

The length of the guide edges measured from the corresponding opener edge shall be

$$L_{265} = 7,0 \text{ mm min.}$$

The intersection of the guide edges and the opener edges shall be rounded off with a radius

$$R_{211} = 0,5 \text{ mm max.}$$

Other corners of the guide and opener edges shall be rounded off with a radius

$$R_{212} = 1,0 \text{ mm max.}$$

8.2.13 Path for shutter opener (Figure 22 and 23)

When the shutter is moved rightwards until the left opener edge is at a distance

$$L_{266} = 26,5 \text{ mm,}$$

from Reference Plane Y, the windows shall be open over

$$L_{267} = 16,5 \text{ mm min.}$$

from L_{252} and over an arc of

$$R_{213} = 17,0 \text{ mm min.}$$

originating at the intersection of L_{252} and L_{256} .

The left-hand opener edge shall be at

$$L_{268} = 26,0 \text{ mm max.}$$

from Reference Plane Y, when the shutter is in its right-hand end position.

When the corresponding position of the right-hand opener edge is

$$L_{269} = 75,5 \text{ mm,}$$

the windows shall be open at L_{267} from L_{252} and with a radius R_{213} originating at the intersection of L_{252} and L_{256} .

The position of the right-hand opener edge shall be

$$L_{270} = 76,0 \text{ mm min.}$$

when the shutter is in its left-hand end position.

8.2.14 Label areas (Figure 24)

The case shall have three label areas on Side A and Side B and on the bottom side, with dimensions

Sides A and B

$$L_{271} = 10,0 \text{ mm} \pm 0,2 \text{ mm}$$

$$L_{272} = 13,0 \text{ mm} \pm 0,2 \text{ mm}$$

$$L_{273} = 76,0 \text{ mm} \pm 0,3 \text{ mm}$$

$$R_{214} = 2,0 \text{ mm} \pm 0,2 \text{ mm}$$

Bottom side

$$L_{274} = 13,0 \text{ mm} \pm 0,2 \text{ mm}$$

$$L_{275} = 76,0 \text{ mm} \pm 0,3 \text{ mm}$$

$$L_{276} = 5,0 \text{ mm} \pm 0,2 \text{ mm}$$

$$L_{277} = 97,0 \text{ mm} \pm 0,3 \text{ mm}$$

$$L_{278} = 1,0 \text{ mm} \pm 0,2 \text{ mm}$$

$$L_{279} = 6,0 \text{ mm} \pm 0,2 \text{ mm.}$$

The label area shall be recessed by 0,2 mm min. on all three sides.

8.2.15 Identification mark for Side A (Figure 25)

Side A shall be identified by an identification mark consisting of one small round projection provided in a concave part on the right-hand side of Side A. The position and dimensions of this identification mark shall be as follows.

$$R_{215} = 0,5 \text{ mm} \begin{array}{l} + 0,1 \text{ mm} \\ - 0,0 \text{ mm} \end{array}$$

$$R_{216} = 18,0 \text{ mm} \pm 1,0 \text{ mm}$$

$$L_{281} = 0,5 \text{ mm} \begin{array}{l} + 0,1 \text{ mm} \\ - 0,0 \text{ mm} \end{array}$$

$$L_{282} = 7,0 \text{ mm} \pm 0,3 \text{ mm}$$

$$L_{283} = 97,0 \text{ mm} \pm 0,4 \text{ mm}$$

$$L_{284} = 0,6 \text{ mm} \begin{array}{l} + 0,1 \text{ mm} \\ - 0,0 \text{ mm} \end{array}$$

8.2.16 Opening and opening cover for taking the disk out of the case

Type 2 case shall have an opening closed by a cover. In the original condition the case contains a disk and the cover is locked in closed position. Sensor hole A1 shall be closed. In order to take out the disk, sensor hole A1 shall be opened, then the cover can be opened and the disk removed from the case. Once sensor hole A1 has been opened, it always remains open whether or not the same disk or another disk has been introduced into the case.

This Ecma Standard does not specify the design of the opening and of the cover. They should be designed so as not to damage the disk. An example of a cover is shown in Annex H.

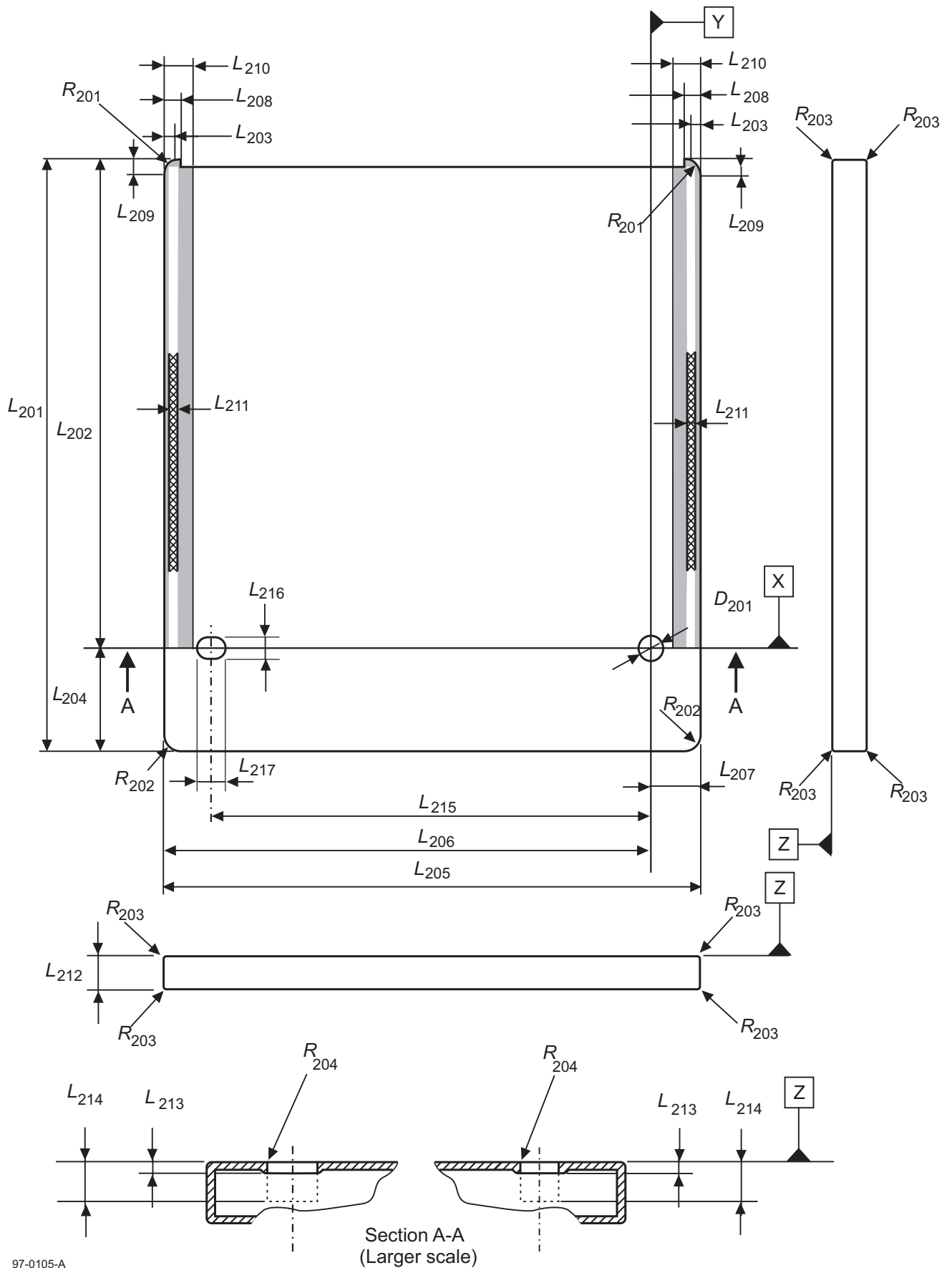

97-0105-A

Figure 16 - Overall dimensions

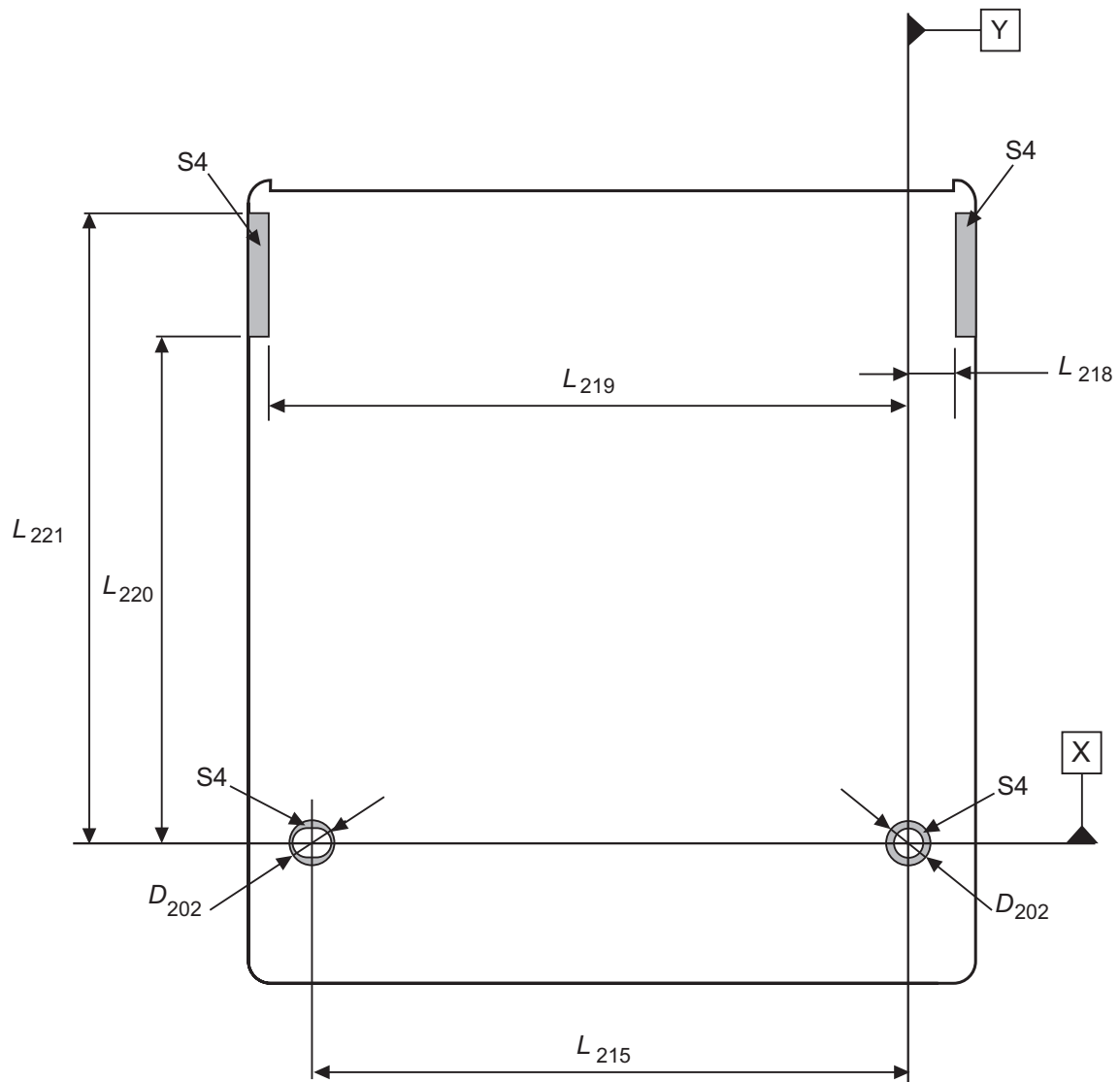

97-0106-A

Figure 17 - Reference surfaces

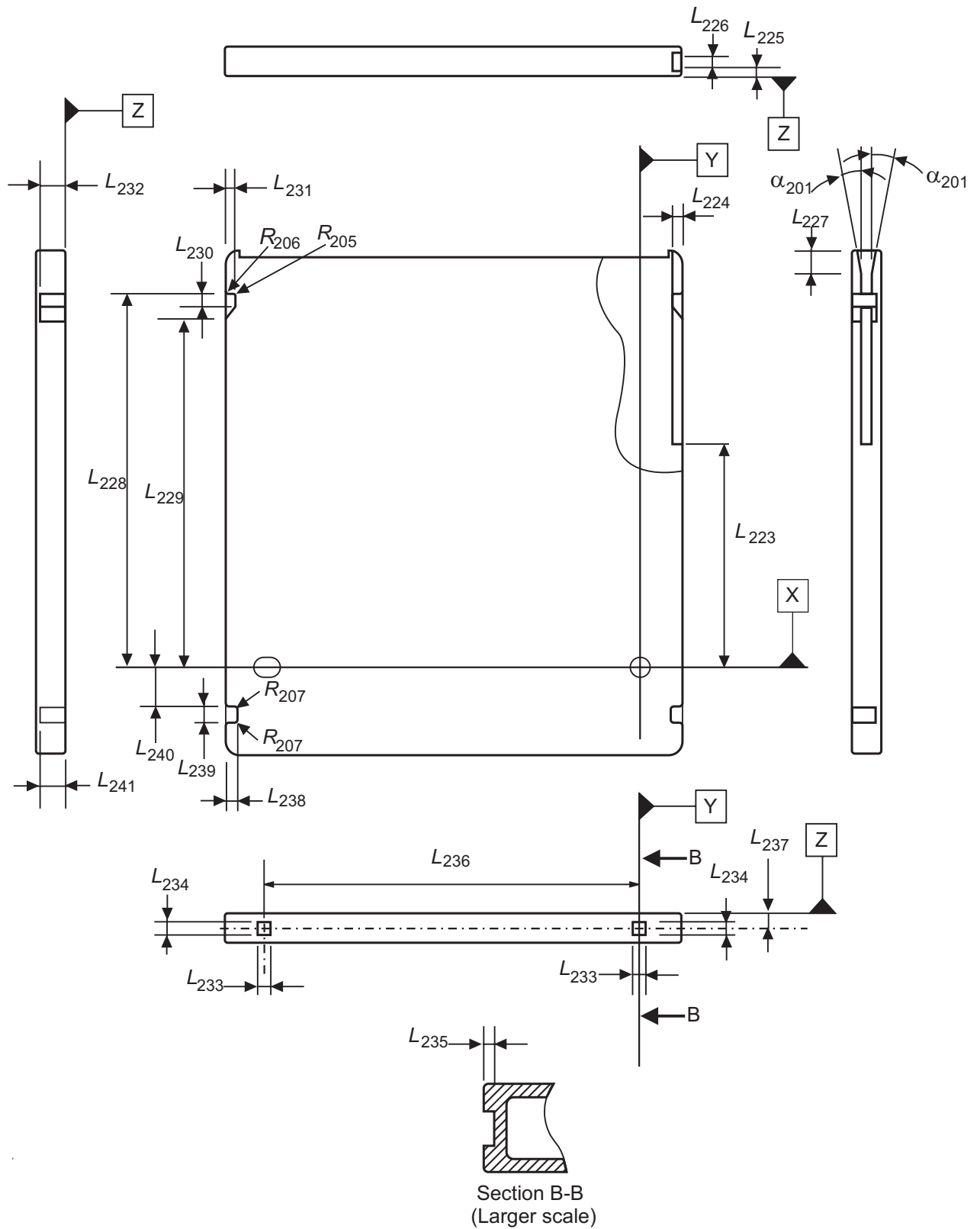

97-0107-A

Figure 18 - Insertion slot, detents and gripper slots

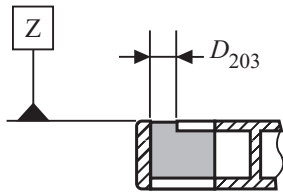
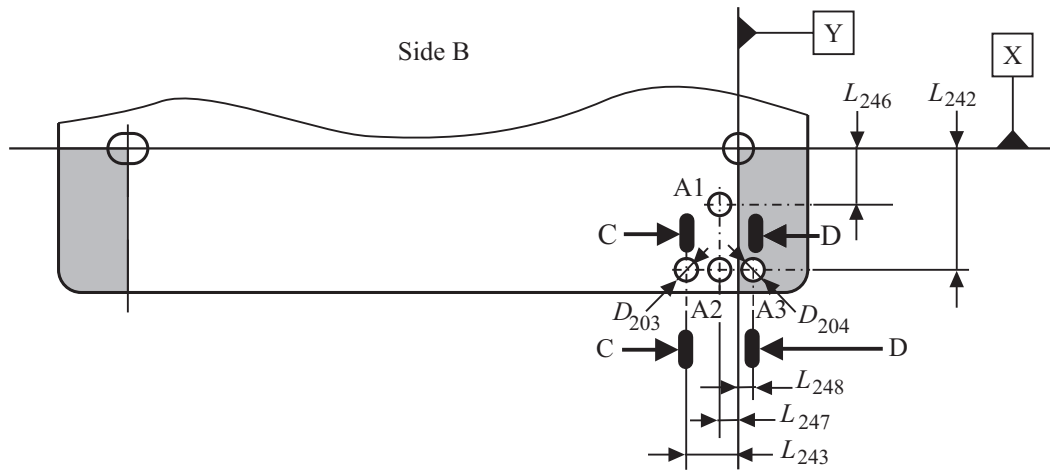

Section C-C
(Larger scale)
Writing permitted

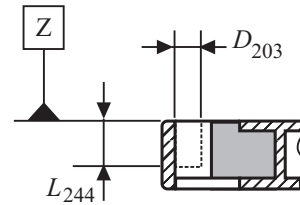

Section C-C
(Larger scale)
Writing inhibited

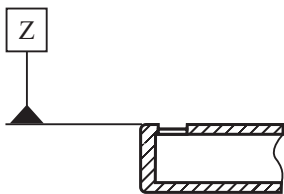

Section D-D
(Larger scale)
Closed

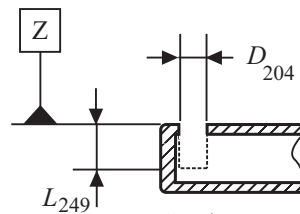

Section D-D
(Larger scale)
Open

01-0091-A

Figure 19 - Write-inhibit hole, sensor holes and sensing areas

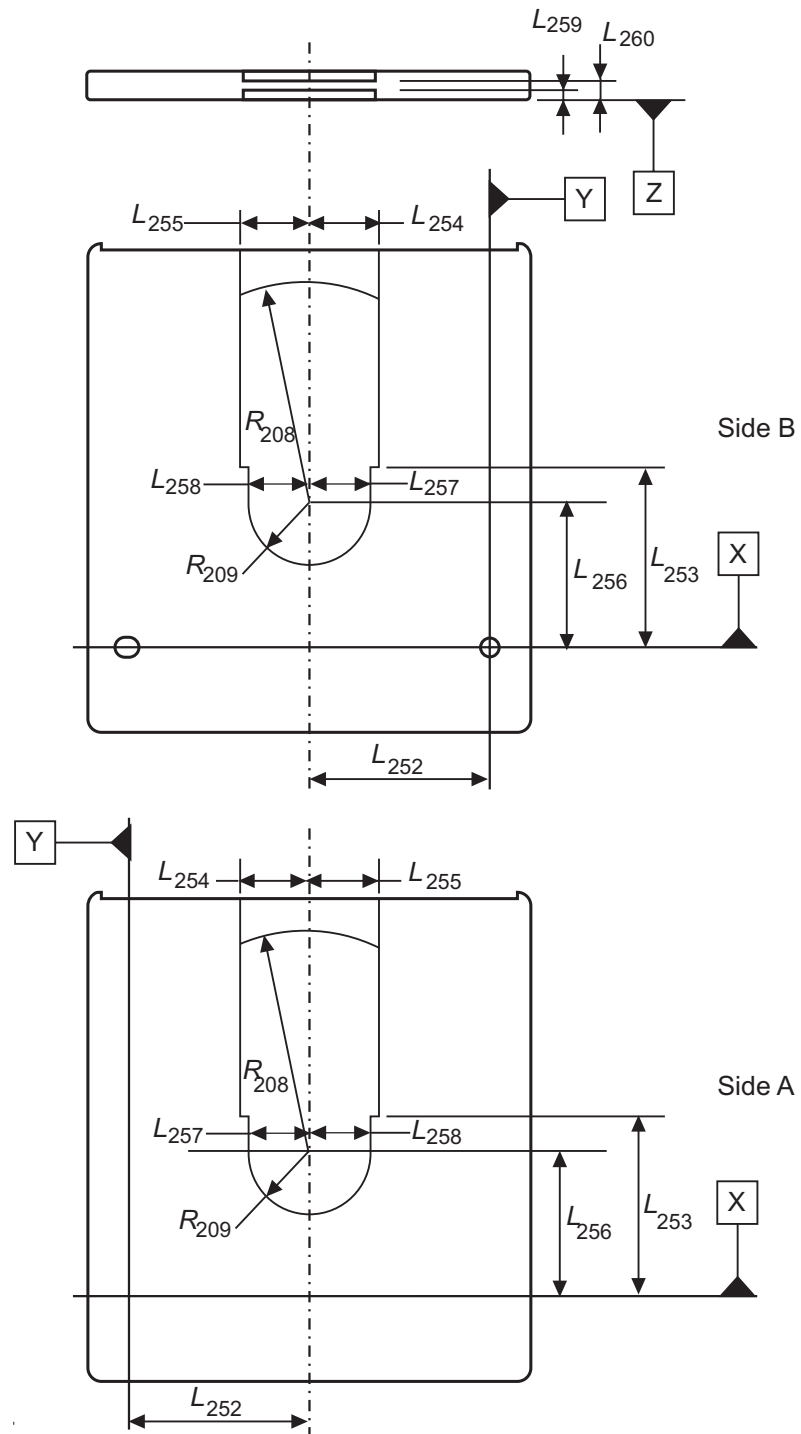

97-0109-A

Figure 20 - Spindle and head window

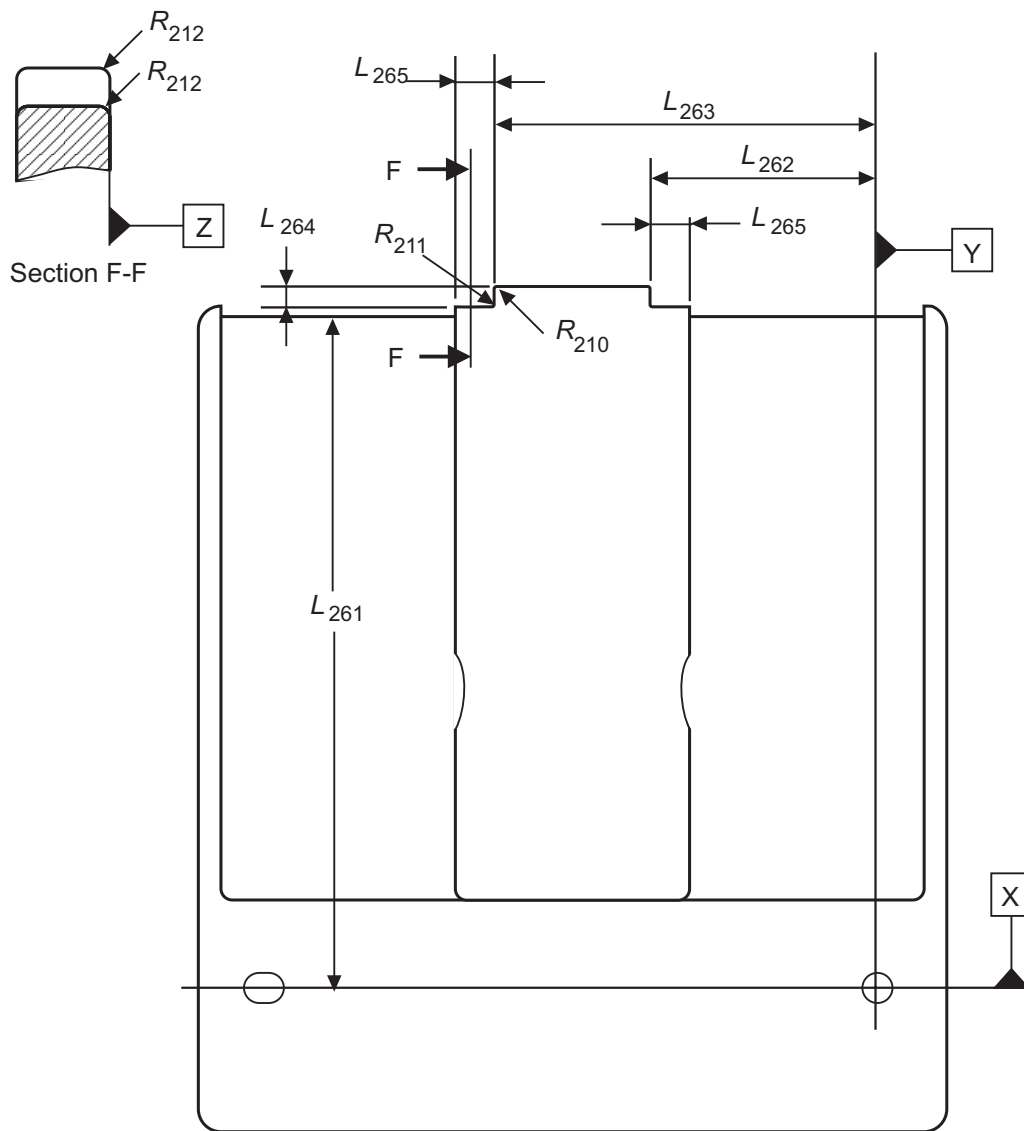

97-0110-A

Figure 21 - Shape of the shutter

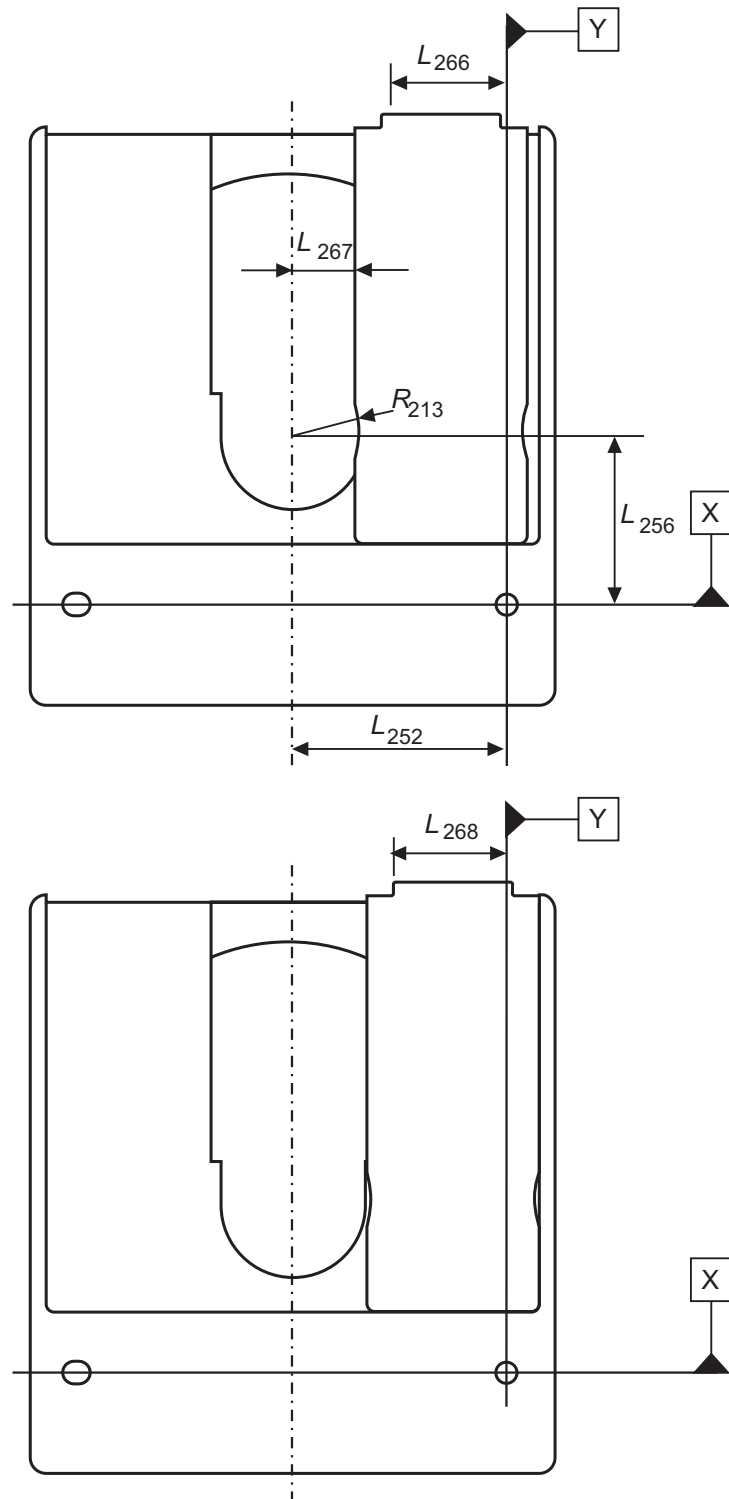

97-0111-A

Figure 22 - Shutter in just right-hand open position (top view) and maximum right-hand open position (bottom view)

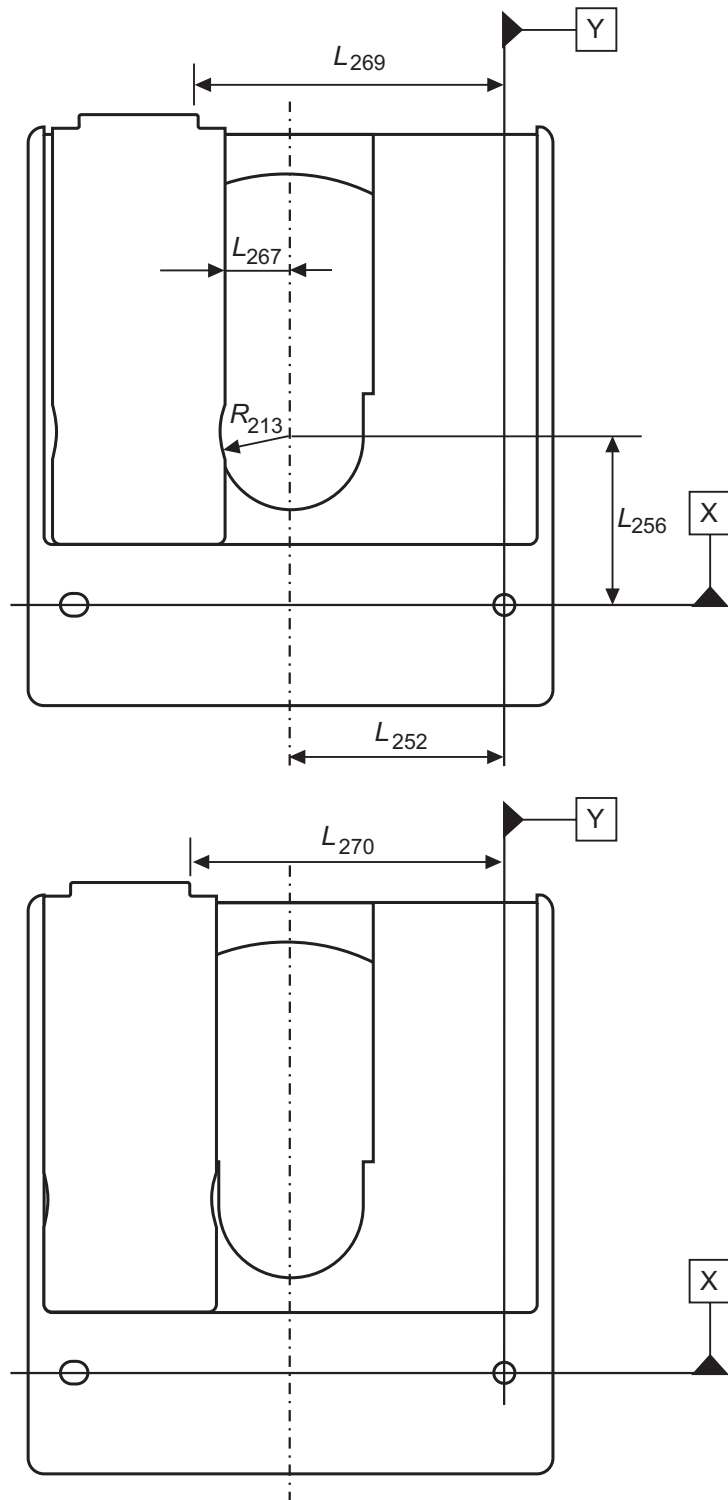

97-0112-A

Figure 23 - Shutter in just left-hand open position (top view) and maximum left-hand open position (bottom view)

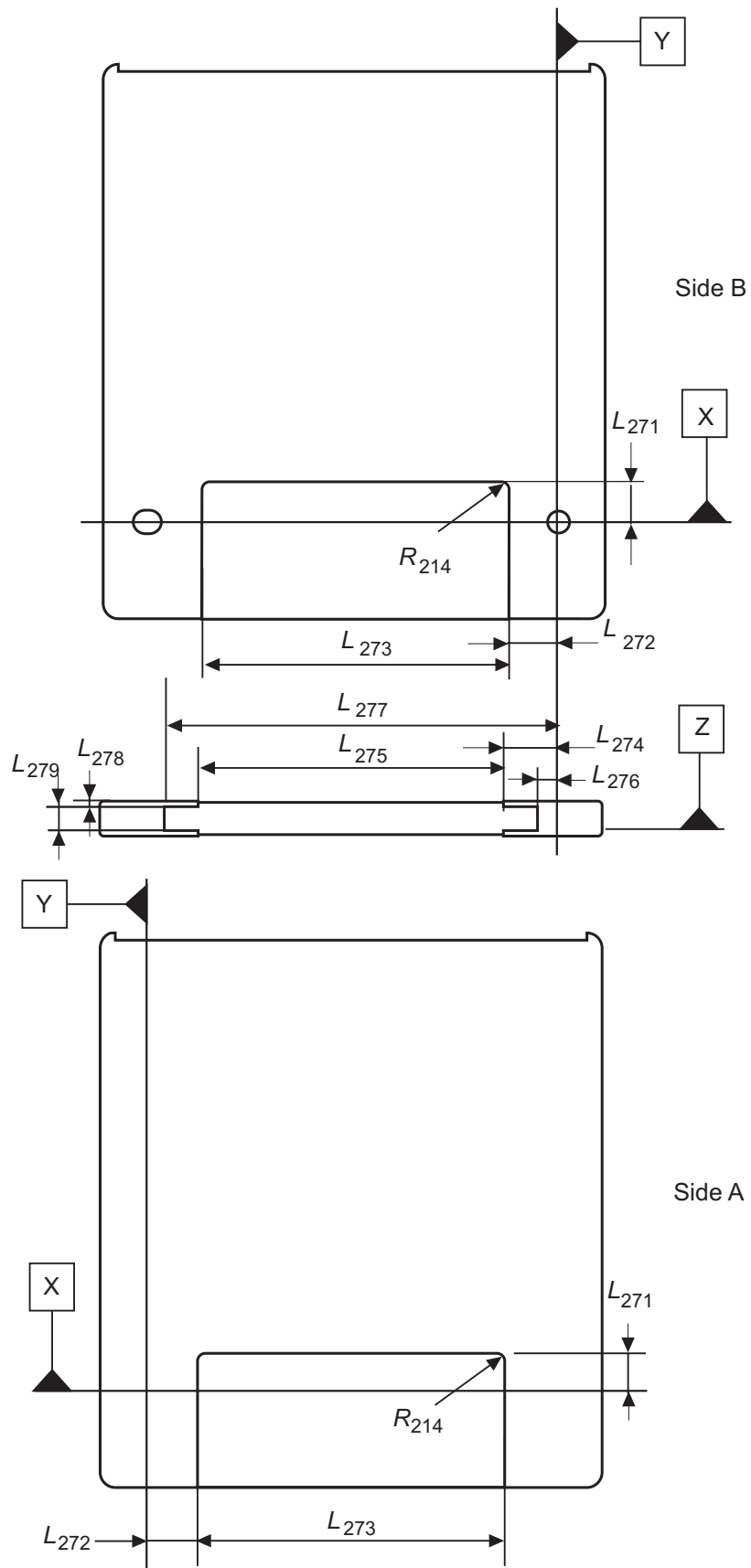

97-0113-A

Figure 24 - Label areas

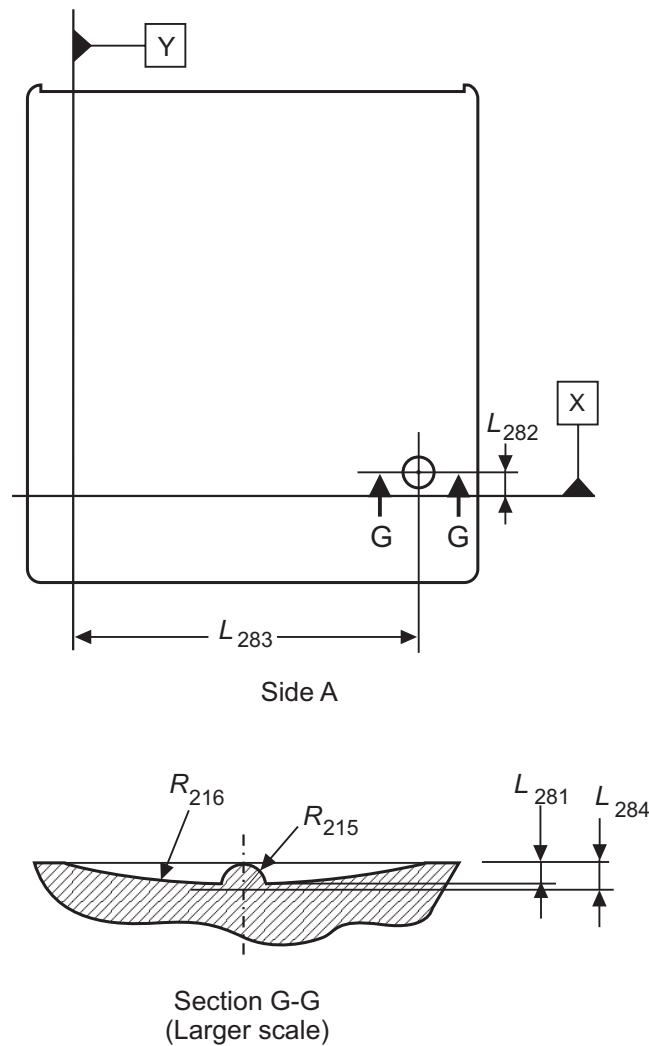

97-0114-A

Figure 25 - Identification mark of Side A

8.3 Dimensions of the Type 3 case

The dimensions of the Type 3 case shall be measured in the test environment (see 7.1.1). The dimensions of the case in an operating environment (see 7.1.2) can be estimated from the dimensions specified in this clause.

The dimensions of the case are identical with those of the Type 2 case. See 8.2.

The following clauses specify different features from the Type 2 case.

8.3.1 Sensor holes

The functions identified by the states of the sensor holes are specified in Table 3.

Table 3 – States of the sensor holes

Sensor hole	Function		State
	Closed	Open	
A1	Not permitted	There may or may not be a disk within the case	Open
A2	Active side	Not permitted	Closed
A3	Reserved for future standardization		Closed

8.3.2 Opening and opening cover for taking the disk out of the case

The case shall have an opening and an opening cover for taking a disk out or putting one in. The opening cover can be opened and closed freely.

A sample of an opening cover is shown in Annex H.

8.4 Dimensions of the Type 4 case

The dimensions of the Type 4 case shall be measured in the test environment (see 7.1.1). The dimensions of the case in an operating environment (see 7.1.2) can be estimated from the dimensions specified in this clause.

The dimensions of the case are identical with those of the Type 1 case. See 8.1.

The following clauses specify different features from the Type 1 case.

8.4.1 Sensor holes

The functions identified by the states of the sensor holes are specified in Table 4.

Table 4 - States of the sensor holes

Sensor hole	Function		State
	Closed	Open	
A1	The original disk has not been taken out	The original disk has been taken out or a disk has been put in	Closed / Open
A2	Active side	Not permitted	Closed
A3	Reserved for future standardization		Closed
B1	The original disk has not been taken out	The original disk has been taken out or a disk has been put in	Closed / Open
B2	Active side	Not permitted	Closed
B3	Reserved for future standardization		Closed

8.4.2 Opening and opening cover for taking the disk out of the case

Type 4 case shall have an opening closed by a cover. In the original condition the case contains a disk and the cover is locked in closed position. Sensor hole A1 and B1 shall be closed. In order to take out the disk, sensor hole A1 and B1 shall be opened, then the cover can be opened and the disk removed from the case. Once sensor hole A1 and B1 have been opened, it always remains open whether or not the same disk or another disk has been introduced into the case.

This Ecma Standard does not specify the design of the opening and of the cover. They should be designed so as not to damage the disk. An example of a cover is shown in Annex H.

8.5 Dimensions of the Type 5 case

The dimensions of the Type 5 case shall be measured in the test environment (see 7.1.1). The dimensions of the case in an operating environment (see 7.1.2) can be estimated from the dimensions specified in this clause.

The dimensions of the case are identical with those of the Type 1 case. See 8.1.

The following clauses specify different features from the Type 1 case.

8.5.1 Sensor holes

The functions identified by the states of the sensor holes are specified in Table 5.

Table 5 - States of the sensor holes

Sensor hole	Function		States
	Closed	Open	
A1	Not permitted	There may or may not be a disk within the case	Open
A2	Active side	Not permitted	Closed
A3	Reserved for future standardization		Closed
B1	Not permitted	There may or may not be a disk within the case	Open
B2	Active side	Not permitted	Closed
B3	Reserved for future standardization		Closed

8.5.2 Opening and opening cover for taking the disk out of the case

The case shall have an opening and an opening cover for taking a disk out or putting one in. The opening cover can be opened and closed freely.

A sample of an opening cover is shown in Annex H.

9 Mechanical characteristics

9.1 Material

The case shall be constructed from any suitable materials such that it meets the requirements of this Ecma Standard.

9.2 Mass

The mass of the case without the disk shall not exceed 100 g.

9.3 Edge distortion

The cartridge shall meet the requirement of the edge distortion test defined in Annex B.

9.4 Compliance

The case shall meet the requirement of the compliance (flexibility) test defined in Annex C.

9.5 Shutter opening force

The spring force on the shutter shall be such that the force required to open the shutter does not exceed 2,0 N. It shall be sufficiently strong to close a free-sliding shutter, irrespective of the orientation of the case.

10 Interface between the case used as cartridge and a drive

10.1 Capture cylinder (Figure 26)

The capture cylinder is defined as the volume within which the spindle can expect the centre of the disk hole to be, just prior to capture, and with the cartridge constrained as specified in 9.4. The size of the cylinder defines the permissible play of the disk inside its cavity in the case. The cylinder is referred to perfectly located and perfectly sized alignment and location pins in the drive; it includes the tolerances of those dimensions of the case and the disk which are between the two pins mentioned and the centre of the disk.

The bottom of the cylinder shall be parallel to, and above, Reference Plane Z at a distance

$$L_{301} = 2,1 \text{ mm min.}$$

The top of the cylinder shall be located at a distance

$$L_{302} = 5,2 \text{ mm max.}$$

from Reference Plane Z. The diameter of the cylinder shall be

$$D_{301} = 2,8 \text{ mm max.}$$

and its centre shall be given by the nominal values of L_{150} and L_{154} for Type 1, Type 4 and Type 5; or by L_{254} and L_{258} for Type 2 and or Type 3 cases, in the drive.

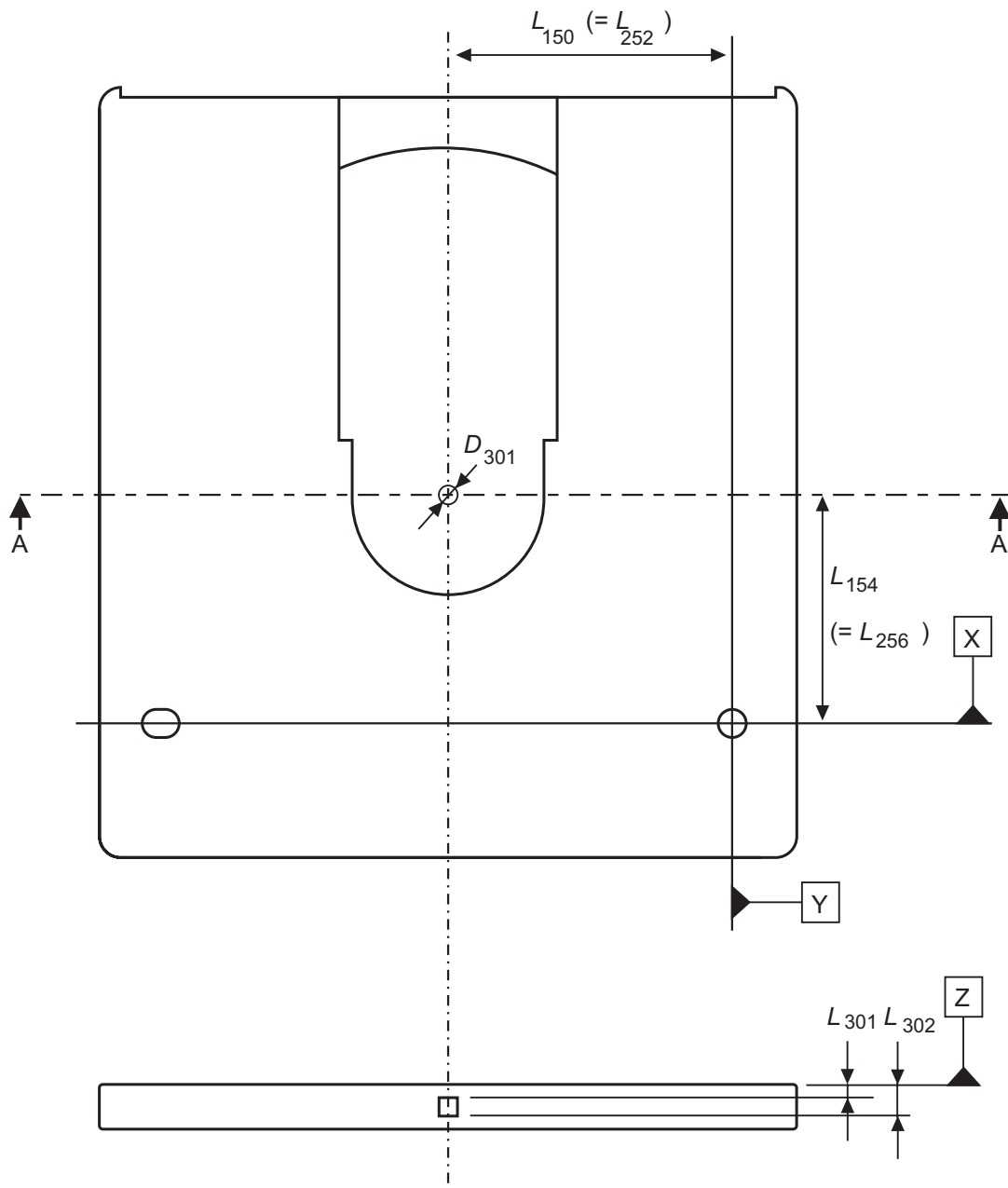

Section A-A
(Larger scale)

97-0115-A

Figure 26 - Capture cylinder

10.2 Inner dimensions of the case (Figure 27)

The inner space of the disk shall be such that the disk is not in contact with the case during operation. The inner shape of the case shall meet the following requirements.

$L_{303} = 2,2 \text{ mm max.}$

$L_{304} = 2,5 \text{ mm max.}$

$L_{305} = 5,4 \text{ mm min.}$

$L_{306} = 5,7 \text{ mm min.}$

measured from Reference Plane Z and

$$R_{301} = 22,0 \text{ mm max.}$$

$$R_{302} = 60,7 \text{ mm min.}$$

from a centre given by the nominal values of L_{150} and L_{154} of Type 1 case, Type 4 case or Type 5 case, or L_{254} and L_{258} of Type 2 and Type 3 cases.

11 Orientation of the disk in the case

11.1 Two-sided disk (Type 2S) in case Types 1, 4 and 5

The disk surfaces are defined as Side A and Side B. Sides A and B of the case are identical as far as the features specified in this Ecma Standard are concerned. The two-sided disk (Type 2S) has no specific orientation in the case. Therefore, references to Sides A and B of the case can be changed to B and A respectively.

11.2 One-sided disk (Type 1S) in case Types 1, 2 and 3

A one-sided disk (Type 1S) has only one functional entrance surface defined as Side A. The disk shall be oriented in the case so that when Side A of the case faces upwards, Side A of the disk faces downwards.

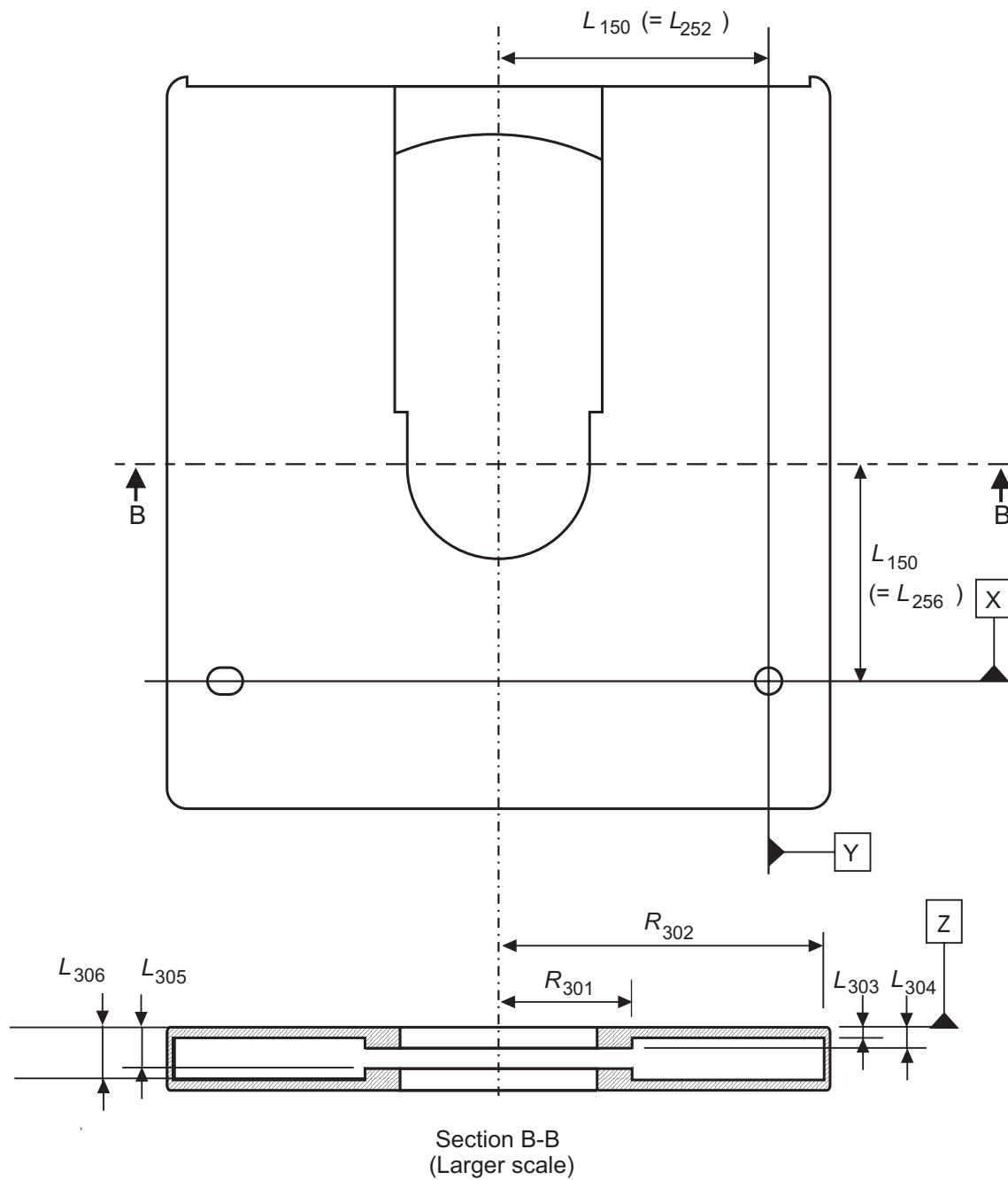

97-0116-A

Figure 27 - Inner dimensions of the case

Section 3 – Dimensional and Mechanical characteristics of the case for 80 mm disk

12 Dimensional characteristics

The dimensions of the case shall be referred to three orthogonal Reference Planes X, Y and Z. The case shall be constrained such that four reference surfaces S1 to S4 on Side B of the case lie in Reference Plane Z. The intersection of the three planes defines the centre of the location hole. The centre of the alignment hole shall lie on the intersection of Reference Planes X and Z. Refer to Annex D. A dimension of a feature referenced to one of the planes is the shortest distance from the feature to the plane.

Side A of the Type 6 and the Type 8 cases are referred to the three orthogonal Reference Planes X, Y' and Z', where

Y' is a plane parallel to Reference Plane Y at a nominal distance of 74,0 mm,

Z' is a plane parallel to Reference Plane Z at a nominal distance of 5,4 mm.

12.1 Dimensions of the Type 6 case

The dimensions of the Type 6 case shall be measured in the test environment (see 7.1.1). The dimensions of the case in an operating environment (see 7.1.2) can be estimated from the dimensions specified in this clause.

12.1.1 Overall dimensions (Figure 28)

The total length of the case shall be

$$L_{101} = 91,0 \text{ mm} \pm 0,3 \text{ mm.}$$

The distance from the top of the case to Reference Plane X shall be

$$L_{102} = 77,0 \text{ mm} \begin{array}{l} + 0,3 \text{ mm} \\ - 0,2 \text{ mm} \end{array}$$

with the width

$$L_{103} = 2,0 \text{ mm min.}$$

from the left-hand and right-hand edges of the case.

The distance from the bottom of the case to Reference Plane X shall be

$$L_{104} = 14,0 \text{ mm} \pm 0,2 \text{ mm.}$$

The total width of the case shall be

$$L_{105} = 89,0 \text{ mm} \pm 0,2 \text{ mm}$$

The distance from the left-hand side of the case to Reference Plane Y shall be

$$L_{106} = 7,5 \text{ mm} \pm 0,2 \text{ mm}$$

The distance from the right-hand side of the case to Reference Plane Y shall be

$$L_{107} = 81,5 \text{ mm} \pm 0,3 \text{ mm}$$

The four corners shall be rounded off with a radius of

$$R_{101} = 2,5 \text{ mm} \pm 0,1 \text{ mm.}$$

In the zones delimited by

$$L_{108} = 6,0 \text{ mm}$$

from the left-hand and right-hand edges of the case, there shall be the continuous guide areas running from the top to Reference Plane X of the case, with a width

$$L_{109} = 0,7 \text{ mm min.}$$

The thickness of the case shall be

$$L_{110} = 5,4 \text{ mm} \begin{array}{l} + 0,2 \text{ mm} \\ - 0,1 \text{ mm.} \end{array}$$

The eight long edges of the case shall be rounded off with a radius

$$R_{102} = 0,4 \text{ mm} \pm 0,1 \text{ mm.}$$

The flat area width of the top shall be

$$L_{111} = 0,5 \text{ mm max.}$$

12.1.2 Location hole (Figure 28)

The centre of the location hole shall coincide with the intersection of Reference Planes X, Y and Z.

The diameter of the hole shall be

$$D_{101} = 3,00 \text{ mm} \begin{array}{l} + 0,05 \text{ mm} \\ - 0,00 \text{ mm} \end{array}$$

Its depth shall be

$$L_{112} = 0,8 \text{ mm min.}$$

The room below the location hole shall be free up to

$$L_{113} = 4,0 \text{ mm min.}$$

below Reference Plane Z.

The diameter of the free room shall be at least equal to D_{101} .

The lead-in edges shall be rounded off with a radius

$$R_{103} = 0,3 \text{ mm} \begin{array}{l} + 0,1 \text{ mm} \\ - 0,0 \text{ mm.} \end{array}$$

12.1.3 Alignment hole (Figure 28)

The centre of the alignment hole shall lie on the intersection of the Reference Planes X and Z at a distance

$$L_{114} = 74,0 \text{ mm} \pm 0,2 \text{ mm}$$

from Reference Plane Y.

The alignment hole shall have a substantially rectangular shape. Its dimensions shall be

$$L_{115} = 3,00 \text{ mm} \begin{array}{l} + 0,05 \text{ mm} \\ - 0,00 \text{ mm} \end{array}$$

$$L_{116} = 3,8 \text{ mm} \begin{array}{l} + 0,2 \text{ mm} \\ - 0,0 \text{ mm} \end{array}$$

Its depth shall be equal to L_{112} . The room below the alignment hole shall be free up to at least L_{113} . The dimensions of the free room shall be at least L_{115} and L_{116} .

The lead-in edges shall be rounded off with a radius R_{103} .

12.1.4 Reference surfaces (Figure 29)

There shall be four reference surfaces S1, S2, S3 and S4 on Side B of the case.

Surfaces S1 and S2 shall be rectangular with a width of

$$L_{117} = 6,0 \text{ mm min.}$$

with the centre located at Reference Plane X and these corners shall be rounded off with a radius of

$$R_{104} = 3,0 \text{ mm min.}$$

originating the centre of the location hole for surface S1 and the centre of the alignment hole for surface S2.

Surfaces S3 and S4 shall be rectangular with dimensions

$$L_{118} = 5,7 \text{ mm max.}$$

$$L_{119} = 79,7 \text{ mm max.}$$

from Reference Plane Y and

$$L_{120} = 64,0 \text{ mm max.}$$

$$L_{121} = 72,0 \text{ mm min.}$$

from Reference Plane X.

12.1.5 Mis-insertion protection slots (Figure 30)

The case shall have two symmetrical mis-insertion protection slots.

The edge of the slots shall be at a distance

$$L_{123} = 7,0 \text{ mm} \pm 0,3 \text{ mm}$$

from Reference Plane X.

The slope start point measured from the edge shall be

$$L_{124} = 3,5 \text{ mm} \pm 0,2 \text{ mm.}$$

The slope end point measured from the edge shall be

$$L_{125} = 1,0 \text{ mm} \pm 0,1 \text{ mm.}$$

The depth measured from the edge of the case shall be

$$L_{126} = 2,0 \text{ mm} \pm 0,1 \text{ mm.}$$

The inside edge corner of the slots shall be rounded off with a radius of

$$R_{105} = 0,5 \text{ mm max.}$$

The outside edge corner of the slots shall be rounded off with a radius of

$$R_{106} = 0,3 \text{ mm} \pm 0,1 \text{ mm.}$$

12.1.6 Detents (Figure 30)

The case shall have two semi-circular, symmetrical detents intended for autoloading.

The position and dimensions of these detents shall be

$$L_{220} = 3,0 \text{ mm} \pm 0,1 \text{ mm}$$

originating from L_{221} and

$$L_{127} = 63,5 \text{ mm} \pm 0,3 \text{ mm}$$

from Reference Plane X.

The width of the detents shall be

$$L_{128} = 3,7 \text{ mm} \pm 0,1 \text{ mm}$$

centre of which shall be located at

$$L_{129} = 2,7 \text{ mm} \pm 0,1 \text{ mm}$$

from Reference Plane Z.

The outside edges of the detents shall be rounded off with a radius

$$R_{108} = 0,4 \text{ mm} \pm 0,1 \text{ mm.}$$

The bottom of the case shall have two symmetrical detents intended for clamping a cartridge in case of vertical use. Their dimensions shall be

$$L_{130} = 2,0 \text{ mm} \pm 0,1 \text{ mm}$$

$$L_{131} = 3,7 \text{ mm} \pm 0,2 \text{ mm}$$

$$L_{132} = 0,7 \text{ mm} \pm 0,1 \text{ mm}$$

The centre of one of these detents shall be at a distance

$$L_{133} = 5,5 \text{ mm} \pm 0,2 \text{ mm}$$

from Reference Plane Y.

The centre of the other shall be at a distance

$$L_{134} = 68,5 \text{ mm} \pm 0,2 \text{ mm}$$

from Reference Plane Y.

Both centres shall be at a distance

$$L_{135} = 2,7 \text{ mm} \pm 0,1 \text{ mm}$$

from Reference Plane Z.

12.1.7 Write-inhibit hole (Figure 31)

The case shall have a write-inhibit hole on both Sides A and B. The write-inhibit hole shall have a device for opening and closing the hole. The hole on Side B of the case is the write-inhibit hole for Side A of the disk. The protected side of the disk shall be identified by an indication on the case, but the indication can be omitted when the device for opening and closing the hole for Side A of the disk can only be operated from Side A of the case.

When writing and erasing on Side A of the disk are not allowed, the write-inhibit hole shall be open. It shall have a diameter

$$D_{102} = 2,5 \text{ mm min.}$$

The position of its centre on Side B shall be specified by

$$L_{136} = 11,5 \text{ mm} \pm 0,2 \text{ mm}$$

$$L_{137} = 13,0 \text{ mm} \pm 0,2 \text{ mm}$$

The hole shall extend below Reference Plane Z by

$$L_{138} = 4,0 \text{ mm min.}$$

with a diameter equal at least to D_{102} .

When writing and erasing of the disk are allowed, the write-inhibit hole shall be closed by the write protect device.

The write protect device shall not be recessed from Reference Plane Z by

$$L_{139} = 0,8 \text{ mm} \begin{matrix} + 0,2 \text{ mm} \\ - 0,1 \text{ mm} \end{matrix}$$

12.1.8 Sensor holes (Figure 31)

The case shall have three sensor holes on Side B. The set of holes on Side B of the case, A1, A2 and A3 pertains to Side A of the disk. The holes shall have a diameter of

$$D_{103} = 2,5 \text{ mm min.}$$

and the positions of their centres shall be specified by L_{136} and

$$L_{140} = 2,0 \text{ mm} \pm 0,2 \text{ mm}$$

$$L_{141} = 3,0 \text{ mm} \pm 0,2 \text{ mm}$$

$$L_{142} = 8,0 \text{ mm} \pm 0,2 \text{ mm.}$$

The room below the holes shall be free by

$$L_{143} = 4,0 \text{ mm min.}$$

Reference Plane Z.

The diameter of the free room shall be at least equal to D_{103} . The holes shall be permitted to extend through Side A.

When a hole for Side A of the disk is closed, the closure shall not be recessed from Reference Plane Z by

$$L_{144} = 0,8 \text{ mm} \begin{matrix} + 0,2 \text{ mm} \\ - 0,1 \text{ mm} \end{matrix}$$

The sensor hole A1 shall indicate whether or not the disk has been taken out of the case. The sensor hole A1 shall be originally closed, and once a disk has been taken out of the case, this hole shall remain permanently open.

Side A of the case shall have corresponding sensor holes B1, B2 and B3 with the diameter D_{103} .

The functions identified by the states of the sensor holes are specified in Table 6.

Table 6 - States of the sensor holes

Sensor hole	Function		State
	Closed	Open	
A1	The original disk has not been taken out	The original disk has been taken out or a disk has been put in	Closed / Open
A2	Cartridge detection	Not permitted	Closed
A3	Reserved for future standardization		Closed
B1	The original disk has not been taken out	The original disk has been taken out or a disk has been put in	Closed / Open
B2	Cartridge detection	Not permitted	Closed
B3	Reserved for future standardization		Closed

12.1.9 Spindle and head window (Figure 32)

The dimensions of the window shall be referenced to a centreline, located at a distance

$$L_{145} = 37,0 \text{ mm} \pm 0,1 \text{ mm}$$

from Reference Plane Y. The width of the window from the top of the case to

$$L_{146} = 40,0 \text{ mm max.}$$

shall be

$$L_{147} = 13,0 \text{ mm} \pm 0,1 \text{ mm}$$

and

$$L_{148} = 13,0 \text{ mm} \pm 0,1 \text{ mm.}$$

The top of the window shall be specified by

$$R_{109} = 40,7 \text{ mm min.}$$

originating from the intersection of L_{145} and

$$L_{149} = 29,0 \text{ mm} \pm 0,1 \text{ mm.}$$

The width of the window with the projection portion shall be

$$L_{150} = 10,0 \text{ mm min.}$$

and

$$L_{151} = 10,0 \text{ mm min.}$$

The width of the window at L_{149} shall be specified by

$$L_{152} = 13,7 \text{ mm} \begin{matrix} + 0,2 \text{ mm} \\ - 0,0 \text{ mm} \end{matrix}$$

and

$$L_{153} = 13,7 \text{ mm} \begin{matrix} + 0,2 \text{ mm} \\ - 0,0 \text{ mm} \end{matrix}$$

The bottom and the projection portion of the window shall be the arc specified by a radius

$$R_{110} = 14,0 \text{ mm min.}$$

Its centre shall be defined by the intersection of L_{145} and L_{149} .

The area bounded by R_{109} and the top of the case shall be recessed from Reference Plane Z by

$$L_{154} = 1,3 \text{ mm min.}$$

over the width of the window.

12.1.10 Shutter shape (Figure 33)

The case shall have a spring-loaded shutter completely covering the spindle and head windows when the case is not inside a drive. The shutter shall be free to slide in a recessed area of the case. The shutter shall not protrude beyond Reference Planes Z or Z' by more than 0,15 mm.

The shutter shall have an opener slot and a pair of opener edges against which the shutter opener of the drive can push to open the shutter. The shutter can be moved toward either the left or the right corresponding to the shutter opener mechanism.

The top of the shutter shall be located at

$$L_{155} = 77,0 \text{ mm} \begin{matrix} + 0,3 \text{ mm} \\ - 0,2 \text{ mm} \end{matrix}$$

from Reference Plane X.

The opener slot shall be defined by the dimensions

$$L_{156} = 5,0 \text{ mm} \pm 0,1 \text{ mm}$$

$$L_{157} = 2,2 \text{ mm} \begin{matrix} + 0,3 \text{ mm} \\ - 0,0 \text{ mm} \end{matrix}$$

$$L_{158} = 2,0 \text{ mm} \pm 0,1 \text{ mm}$$

Its centre shall be specified by the intersection of two lines defined by

$$L_{159} = 37,0 \text{ mm} \pm 0,2 \text{ mm}$$

from Reference Plane Y and

$$L_{160} = 2,7 \text{ mm} \pm 0,1 \text{ mm}$$

from Reference Plane Z when the shutter is closed.

The outside edge corners shall be rounded off with a radius of

$$R_{111} = 0,4 \text{ mm max.}$$

The inside edge corners shall be rounded off with a radius of

$$R_{112} = 0,4 \text{ mm max.}$$

The right opener edge shall be defined by the dimensions

$$L_{222} = 2,2 \text{ mm min.}$$

$$L_{164} = 2,2 \text{ mm} \pm 0,2 \text{ mm}$$

Its centre shall be located at L_{160} .

When the shutter is closed, the right-hand opener edge shall be at

$$L_{161} = 50,7 \text{ mm} \pm 0,3 \text{ mm}$$

from Reference Plane Y.

The case shall have a pair of opener guides through which the opener edge can be pushed by the shutter opener of a drive.

Its projective figure viewed from the case side shall be defined by L_{164} and a width of

$$L_{162} = 2,4 \text{ mm} \pm 0,2 \text{ mm}$$

with the centre located at

$$L_{163} = 2,7 \text{ mm} \pm 0,1 \text{ mm}$$

from Reference Plane Z.

The corner of the opener guides shall be rounded off with a radius of

$$R_{113} = 0,4 \text{ mm} \pm 0,1 \text{ mm.}$$

12.1.11 Path for shutter opener (Figure 34)

When the left-hand edge position of the opener slot is

$$L_{165} = 6,3 \text{ mm,}$$

the shutter shall be open at

$$L_{166} = 12,9 \text{ mm min.}$$

and

$$L_{167} = 13,7 \text{ mm min.}$$

from L_{145} .

When the position of the right-hand opener edge is

$$L_{168} = 22,5 \text{ mm,}$$

the shutter shall be open at L_{166} and L_{167} .

The left-hand edge portion of the opener slot shall be

$$L_{169} = 5,9 \text{ mm max.}$$

and the position of the right-hand opener edge shall be

$$L_{170} = 22,1 \text{ mm max.}$$

when the shutter completely moves up.

12.1.12 Label areas (Figure 35)

The case shall have two label areas on Side A and Side B. Their dimensions shall be

$$L_{171} = 7,1 \text{ mm} \pm 0,2 \text{ mm}$$

$$L_{172} = 5,0 \text{ mm} \pm 0,2 \text{ mm}$$

$$L_{173} = 8,0 \text{ mm} \pm 0,2 \text{ mm}$$

$$L_{174} = 66,0 \text{ mm} \pm 0,3 \text{ mm}$$

$$R_{114} = 1,0 \text{ mm} \pm 0,2 \text{ mm}$$

The label area shall be recessed by 0,2 mm min.

12.1.13 Identification marks for Sides A and B (Figure 36)

Side A and Side B shall be identified by an identification mark provided on a concave part on Side A and Side B, respectively. On Side A, this concave part presents a small round projection, on Side B two such projections are provided. The position and dimensions of these identification marks shall be as follows.

Side A

$$R_{115} = 0,4 \text{ mm} \begin{matrix} + 0,1 \text{ mm} \\ - 0,0 \text{ mm} \end{matrix}$$

$$L_{176} = 0,4 \text{ mm} \begin{matrix} + 0,1 \text{ mm} \\ - 0,0 \text{ mm} \end{matrix}$$

$$L_{177} = 10,2 \text{ mm} \pm 0,3 \text{ mm}$$

$$L_{178} = 37,0 \text{ mm} \pm 0,4 \text{ mm}$$

$$L_{179} = 0,5 \text{ mm} \begin{matrix} + 0,1 \text{ mm} \\ - 0,0 \text{ mm} \end{matrix}$$

$$L_{180} = 9,0 \text{ mm} \pm 1,0 \text{ mm}$$

$$L_{181} = 5,0 \text{ mm} \pm 0,5 \text{ mm}$$

Side B

$$R_{115} = 0,4 \text{ mm} \begin{matrix} + 0,1 \text{ mm} \\ - 0,0 \text{ mm} \end{matrix}$$

$$L_{176} = 0,4 \text{ mm} \begin{matrix} + 0,1 \text{ mm} \\ - 0,0 \text{ mm} \end{matrix}$$

$$L_{177} = 10,2 \text{ mm} \pm 0,3 \text{ mm}$$

$$L_{178} = 37,0 \text{ mm} \pm 0,4 \text{ mm}$$

$$L_{179} = 0,5 \text{ mm} \begin{matrix} + 0,1 \text{ mm} \\ - 0,0 \text{ mm} \end{matrix}$$

$$L_{180} = 9,0 \text{ mm} \pm 1,0 \text{ mm}$$

$$L_{181} = 5,0 \text{ mm} \pm 0,5 \text{ mm}$$

$$L_{182} = 3,0 \text{ mm} \pm 0,3 \text{ mm}$$

12.1.14 Disk holder and body (Figures 37 and 38)

The case shall consist of a body and a disk holder to allow the removal or replacement of the disk. In the original condition, the disk holder shall be locked in the body and the sensor holes A1 and B1 closed.

When the status of the sensor holes A1 and B1 changes from closed to open, the disk holder holding a disk can be removed from the case. Once the status of the sensor holes A1 and B1 changes from closed to open, the open status is kept and cannot be changed back to the closed status. The body and the disk holder shall be formed so as not damaging the read-out side of the disk.

The disk holder shall have a pair of holding arms with upper and lower flanges, a grip, a pair of lock levers with a lock portion and a pair of detents. A disk shall be supported among the holding arms and the grip. The disk shall not be removed from the disk holder by a releasing force of 0,35 N or less.

The dimensions of the disk holder shall be as follows, using the three orthogonal reference planes A, B and C.



Arm

- $L_{183} = 22,0 \text{ mm} \pm 0,2 \text{ mm}$
- $L_{184} = 79,0 \text{ mm} \pm 0,2 \text{ mm}$
- $L_{185} = 84,8 \text{ mm} \pm 0,1 \text{ mm}$
- $L_{186} = 74,0 \text{ mm} \pm 0,2 \text{ mm}$
- $L_{187} = 19,5 \text{ mm} \pm 0,2 \text{ mm}$
- $L_{188} = 70,0 \text{ mm} \pm 0,2 \text{ mm}$
- $L_{189} = 70,0 \text{ mm min. (The upper and lower flanges shall not lie within } L_{189})$
- $R_{116} = 38,5 \text{ mm}$
+ 0,1 mm
- 0,0 mm
- $R_{117} = 40,7 \text{ mm}$
+ 0,1 mm
- 0,0 mm
- $R_{118} = 42,4 \text{ mm} \pm 0,1 \text{ mm}$
- $L_{190} = 3,7 \text{ mm} \pm 0,05 \text{ mm}$
- $L_{191} = 2,9 \text{ mm} \pm 0,1 \text{ mm}$
- $L_{192} = 3,1 \text{ mm} \pm 0,05 \text{ mm}$

Grip

- $L_{193} = 43,0 \text{ mm} \pm 0,1 \text{ mm}$
- $L_{194} = 35,5 \text{ mm} \pm 0,1 \text{ mm}$
- $L_{195} = 32,0 \text{ mm}$
+ 0,0 mm
- 0,2 mm
- $L_{196} = 29,0 \text{ mm}$
+ 0,0 mm
- 0,2 mm
- $L_{197} = 0,7 \text{ mm}$
+ 0,0 mm
- 0,2 mm
- $L_{198} = 22,0 \text{ mm}$
+ 0,0 mm
- 0,2 mm
- $L_{199} = 19,0 \text{ mm}$
+ 0,0 mm
- 0,2 mm
- $R_{119} = 0,5 \text{ mm} \pm 0,1 \text{ mm}$
- $R_{120} = 1,2 \text{ mm} \pm 0,1 \text{ mm}$
- $L_{200} = 4,5 \text{ mm} \pm 0,1 \text{ mm}$
- $L_{201} = 3,1 \text{ mm} \pm 0,05 \text{ mm}$
- $L_{202} = 5,4 \text{ mm} \pm 0,05 \text{ mm}$
- $L_{203} = 3,0 \text{ mm}$
+ 0,2 mm
- 0,0 mm
- $L_{204} = 20,0 \text{ mm} \pm 0,1 \text{ mm}$
- $L_{205} = 12,0 \text{ mm} \pm 0,1 \text{ mm}$

$$L_{206} = 0,1 \text{ mm} \begin{array}{l} + 0,1 \text{ mm} \\ - 0,0 \text{ mm} \end{array}$$

$$L_{207} = 0,5 \text{ mm} \begin{array}{l} + 0,1 \text{ mm} \\ - 0,0 \text{ mm} \end{array}$$

$$L_{208} = 1,9 \text{ mm} \pm 0,1 \text{ mm}$$

Lock lever

$$L_{209} = 85,0 \text{ mm} \pm 0,1 \text{ mm}$$

$$L_{210} = 34,5 \text{ mm} \pm 0,1 \text{ mm}$$

$$L_{211} = 1,0 \text{ mm} \pm 0,1 \text{ mm}$$

$$L_{212} = 1,0 \text{ mm} \begin{array}{l} + 0,0 \text{ mm} \\ - 0,3 \text{ mm} \end{array}$$

$$L_{213} = 1,85 \text{ mm} \begin{array}{l} + 0,1 \text{ mm} \\ - 0,3 \text{ mm} \end{array}$$

$$L_{214} = 4,0 \text{ mm} \pm 0,2 \text{ mm}$$

$$L_{215} = 27,8 \text{ mm} \pm 0,2 \text{ mm}$$

$$L_{216} = 36,0 \text{ mm} \pm 0,1 \text{ mm}$$

$$L_{217} = 1,0 \text{ mm} \pm 0,1 \text{ mm}$$

Detent

$$L_{218} = 20,0 \text{ mm} \pm 0,1 \text{ mm}$$

$$R_{121} = 1,5 \text{ mm} \pm 0,1 \text{ mm}$$

The body shall be formed to engage the lock portions and the grip of the disk holder, as an example shown in Annex J.

The body shall have the mis-release protection function for the disk holder with dimensions of L_{123} , L_{124} , L_{125} , L_{126} , R_{105} , R_{106} and

$$L_{219} = 2,7 \text{ mm min.}$$

as shown in Figure 38.

The body shall be formed so as to enable to set the disk holder with its elastic deformation in the condition of entering the disk in the body.

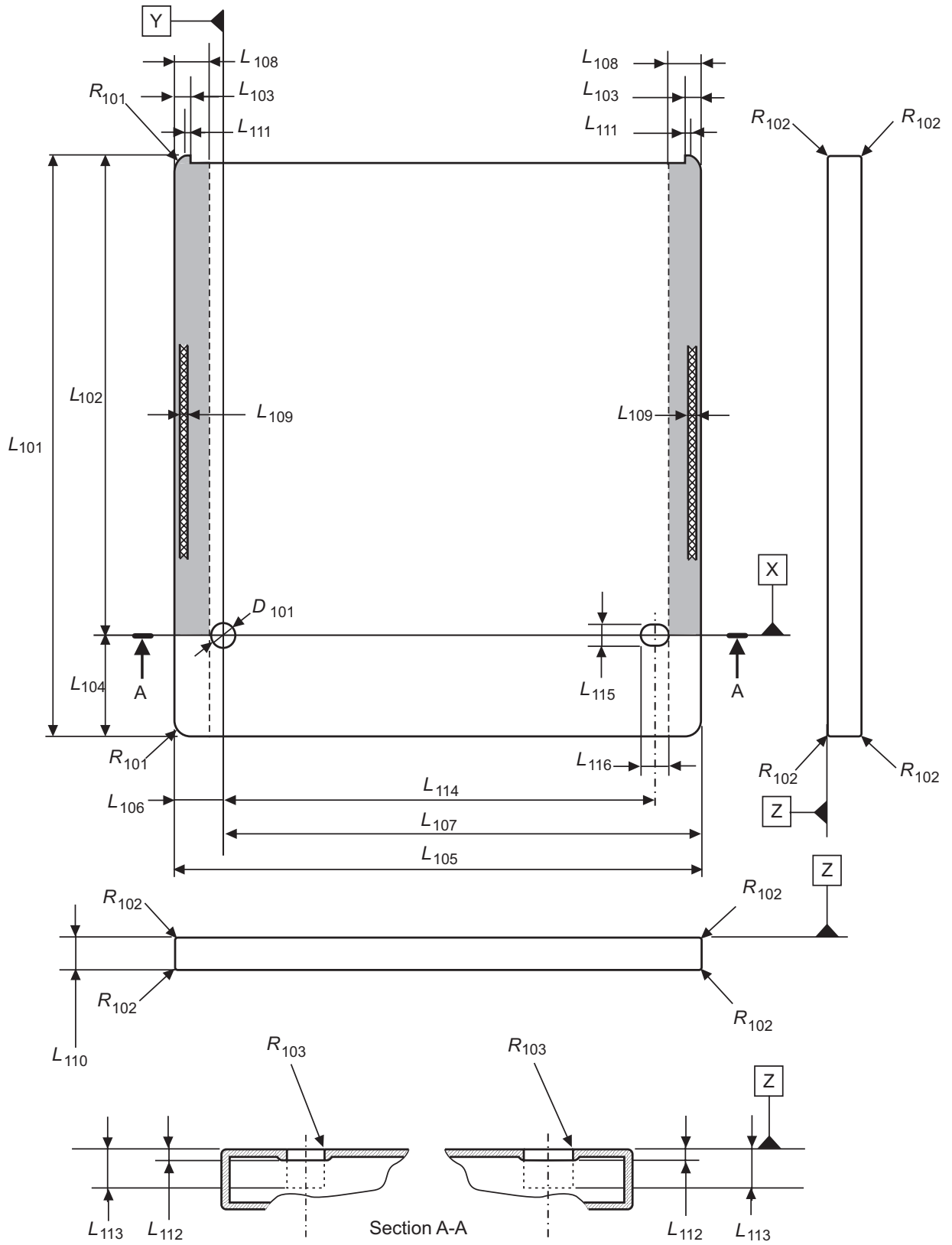

01-0049-A

Figure 28 - Overall dimensions

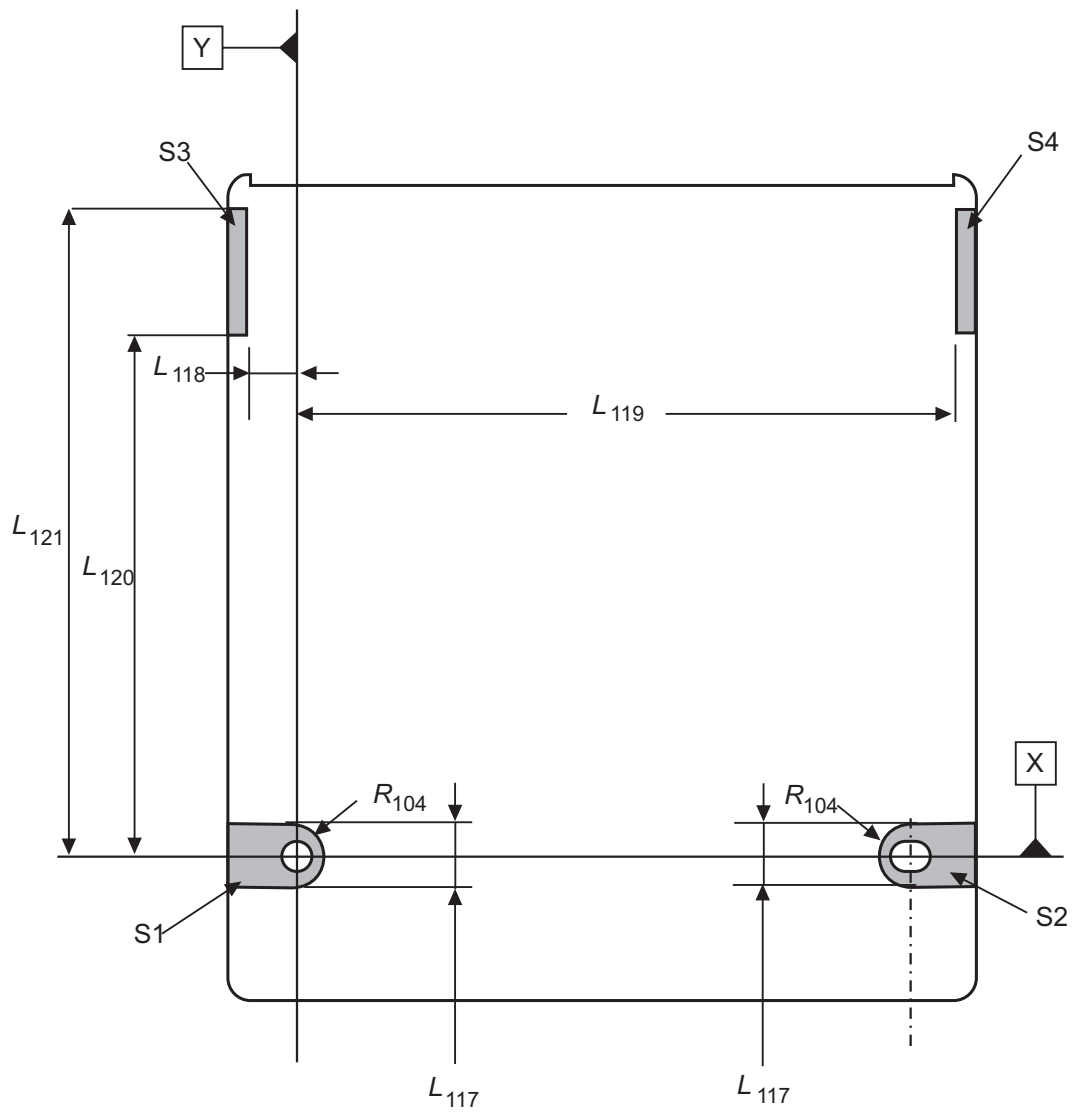

01-0050-A

Figure 29 - Reference surfaces

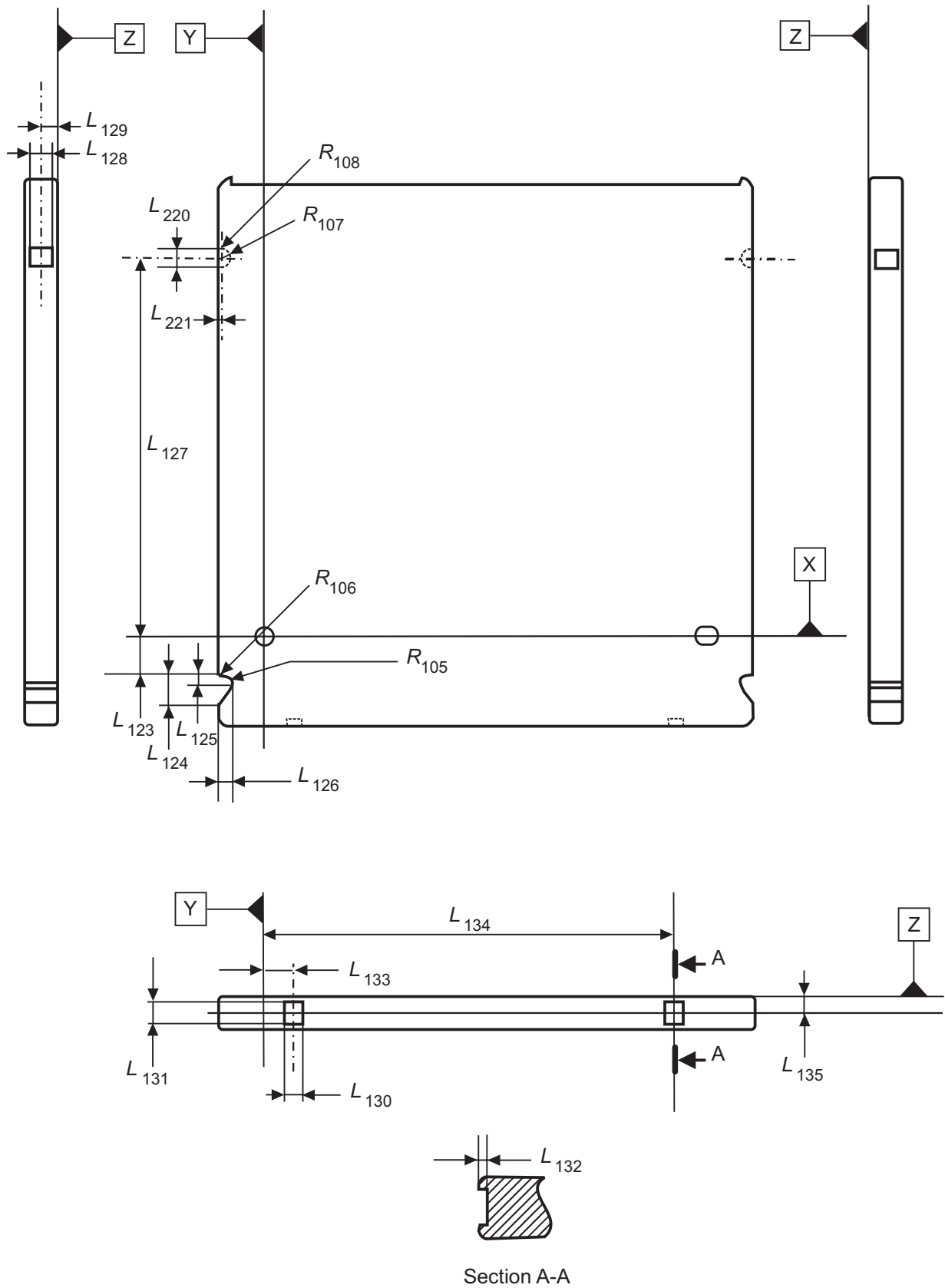

01-0052-A

Figure 30 - Mis-insertion protection slots and detents

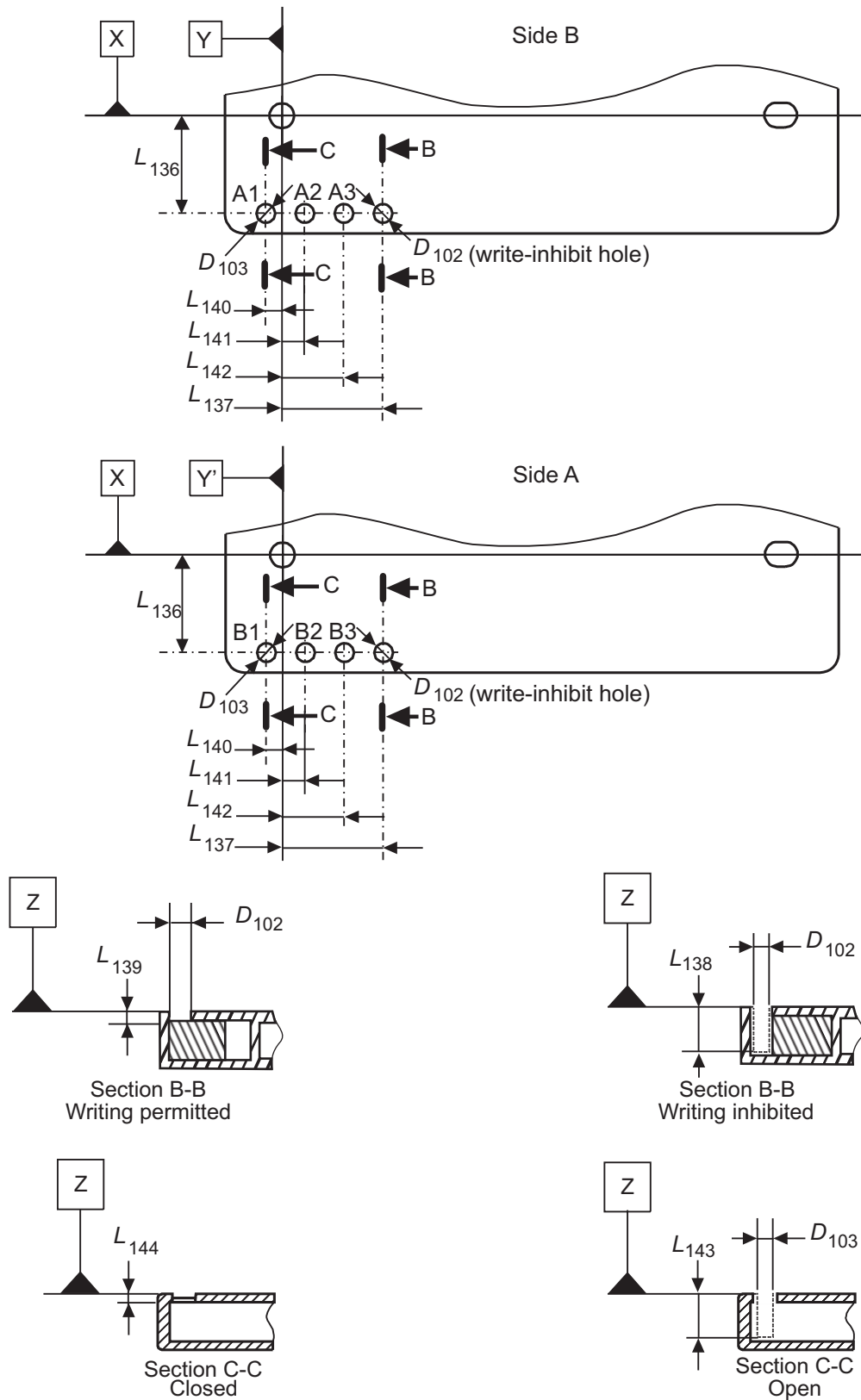

01-0053-A

Figure 31 - Write-inhibit hole and sensor holes

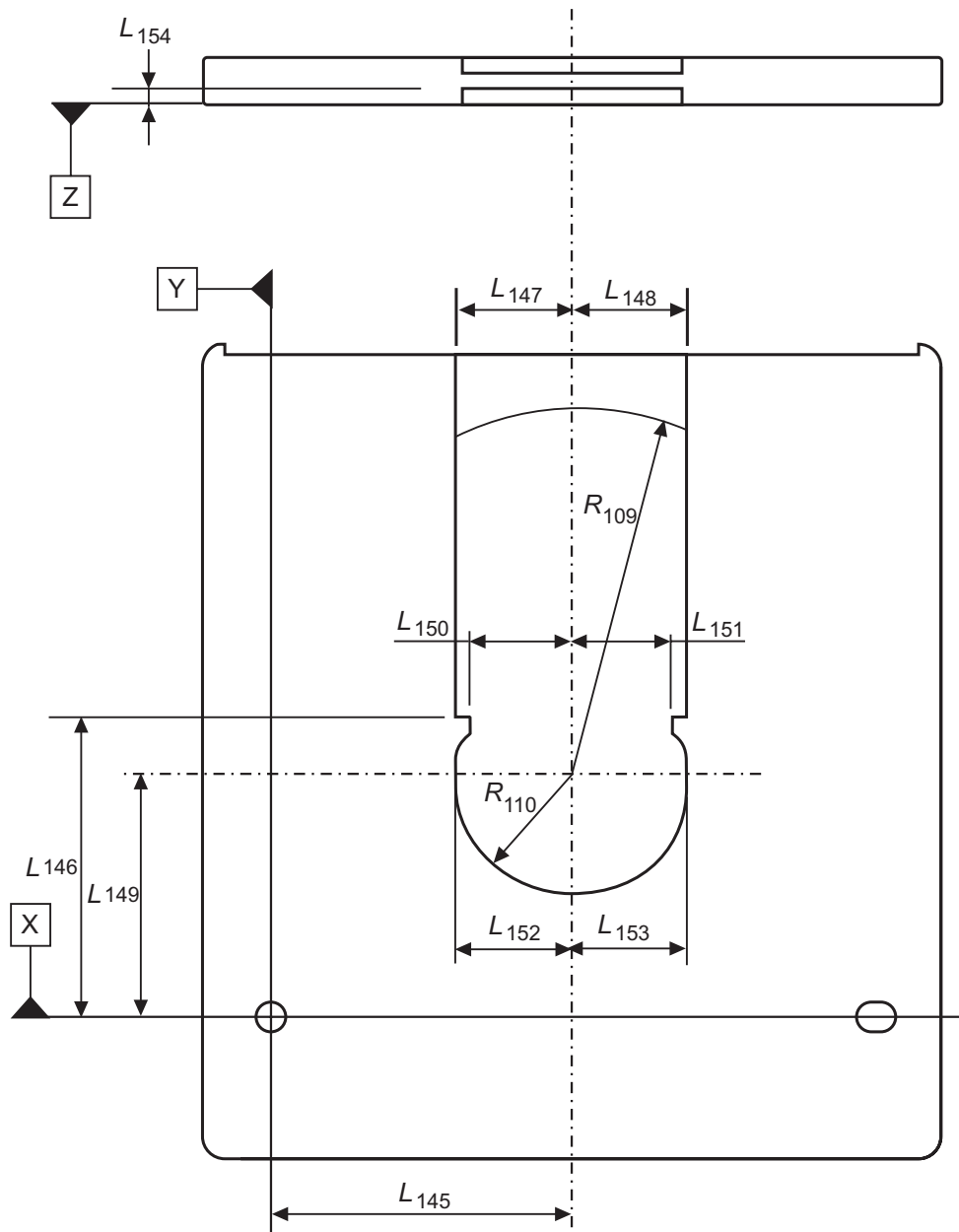

01-0054-A

Figure 32 - Spindle and head window

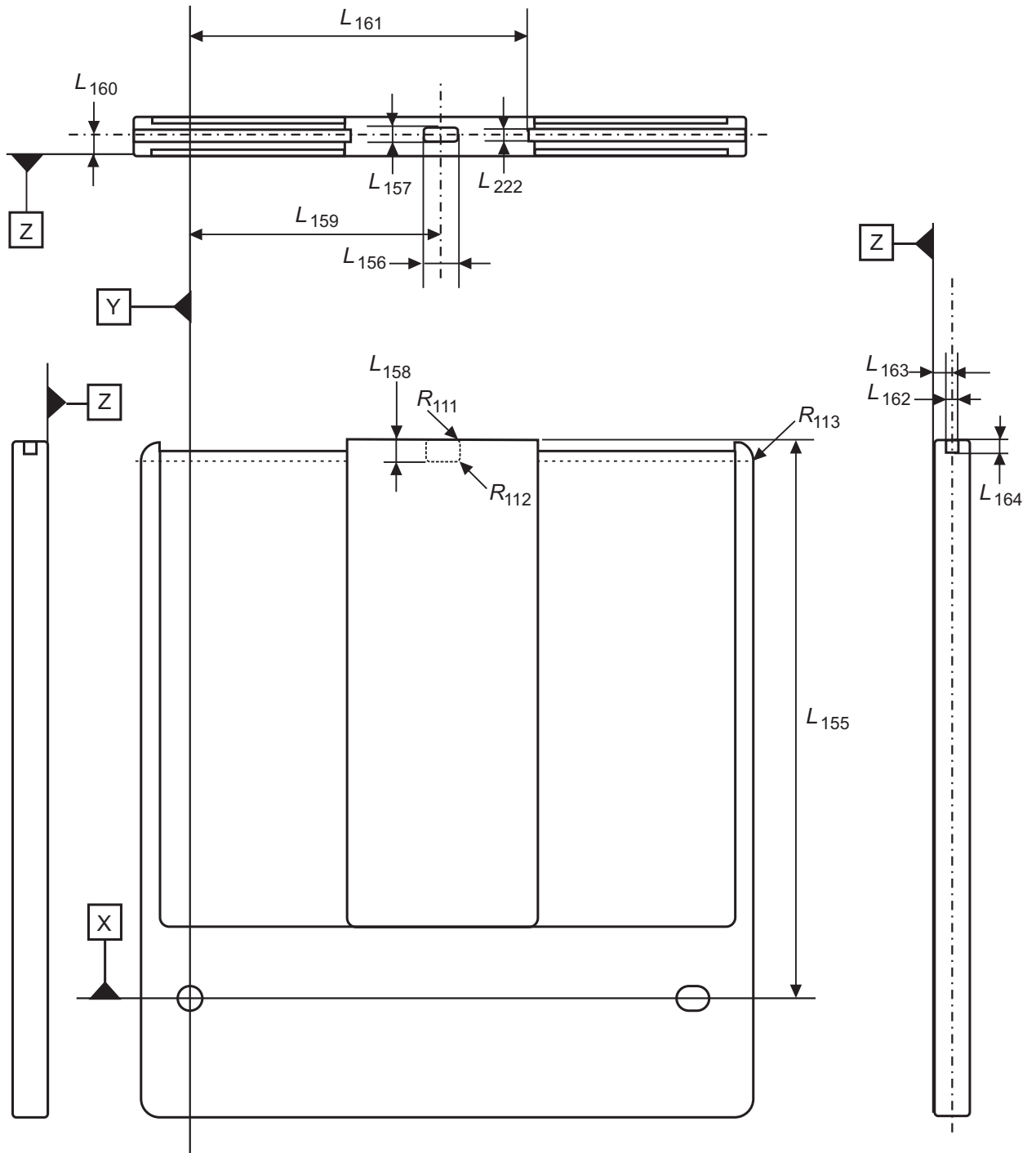

01-0055-A

Figure 33 - Shape of the shutter

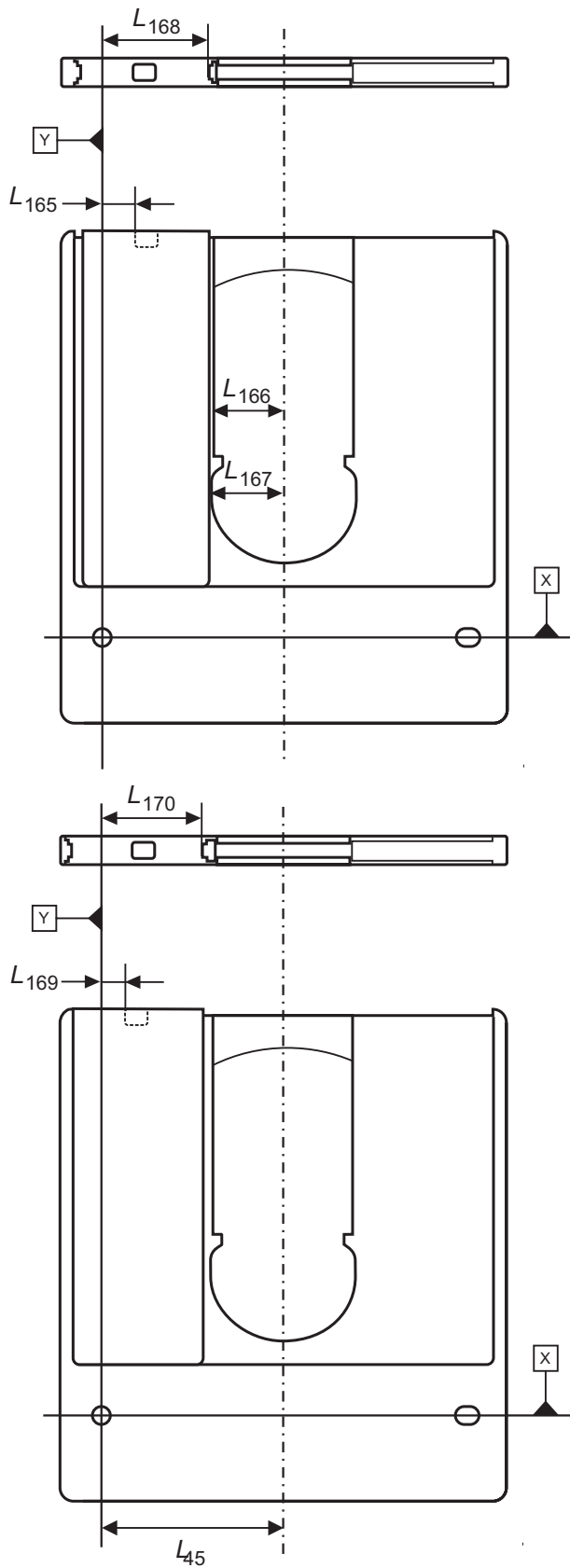

01-0056-A

Figure 34 - Shutter in just open position (top view) and maximum open position (bottom view)

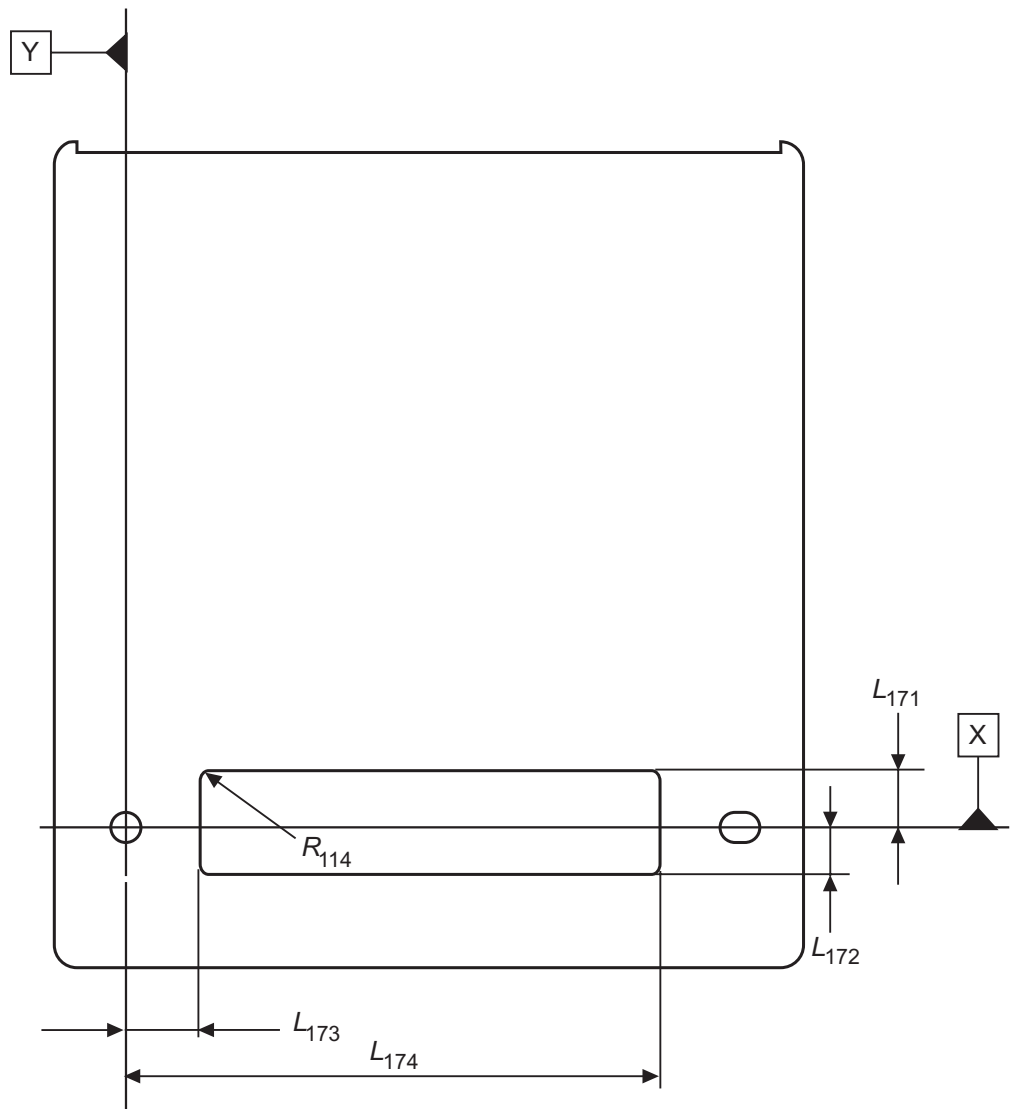

01-0057-A

Figure 35 - Label areas

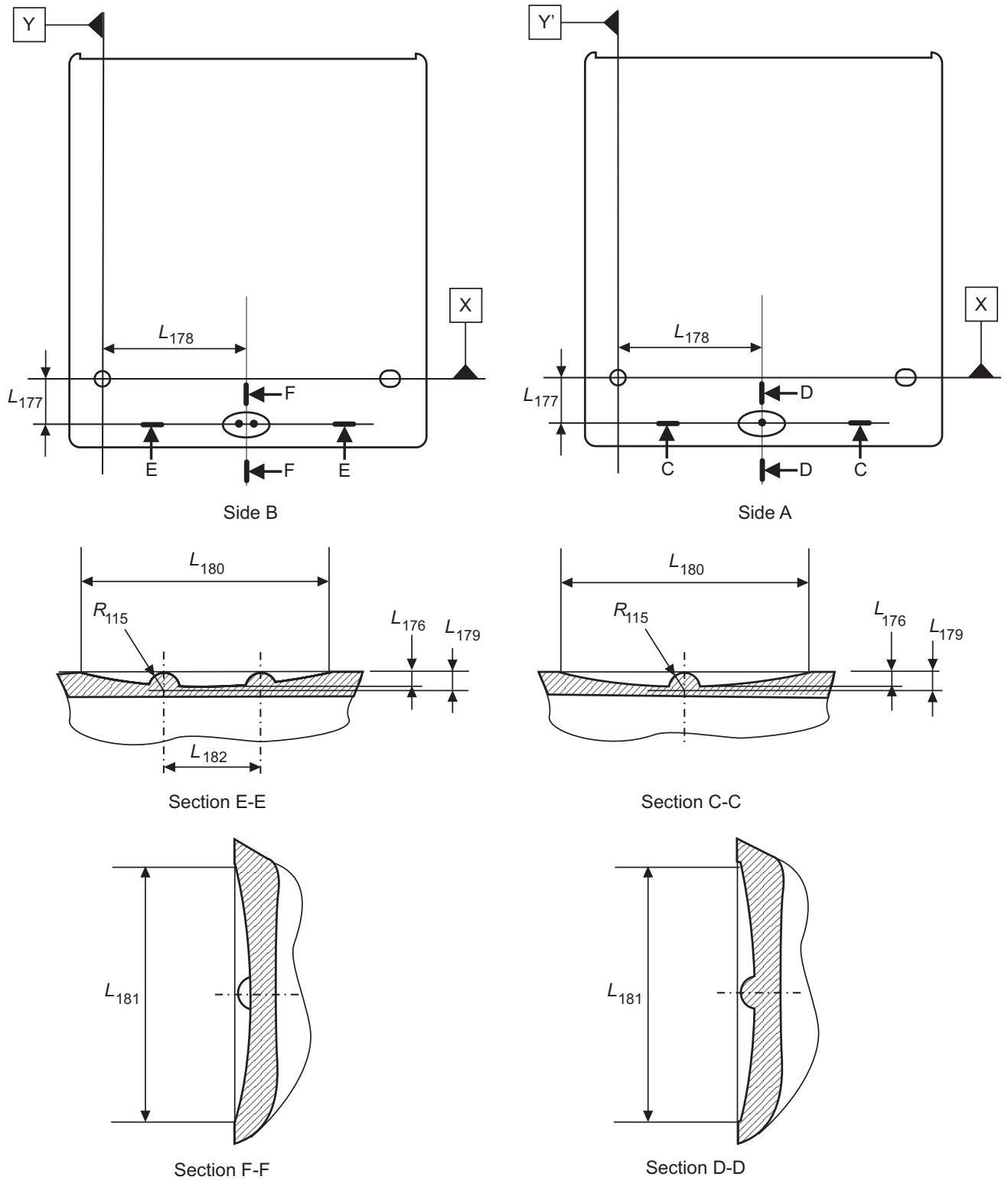

01-0058-A

Figure 36 - Identification marks of Side A and B

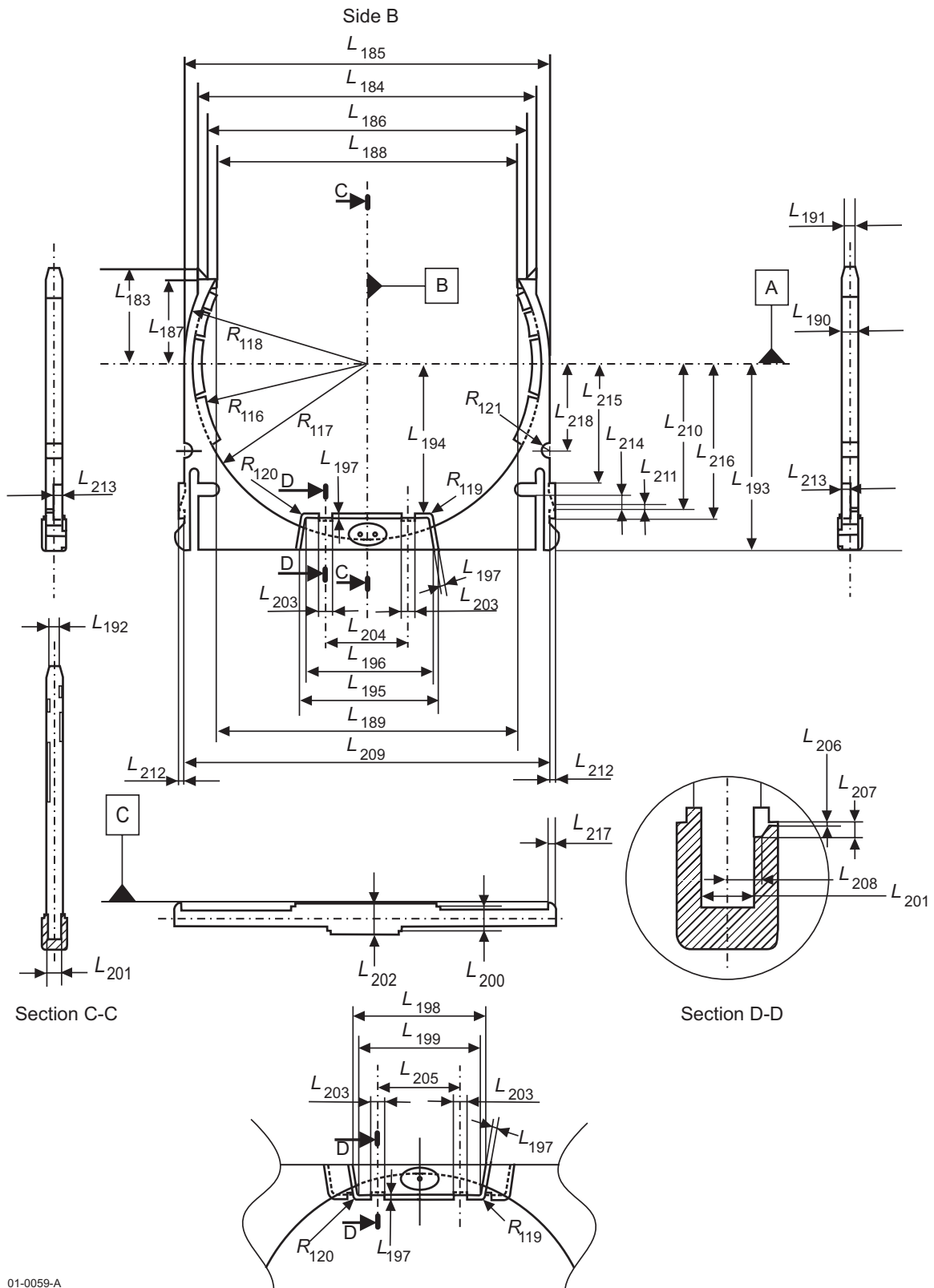

01-0059-A

Figure 37 - Disk holder shape

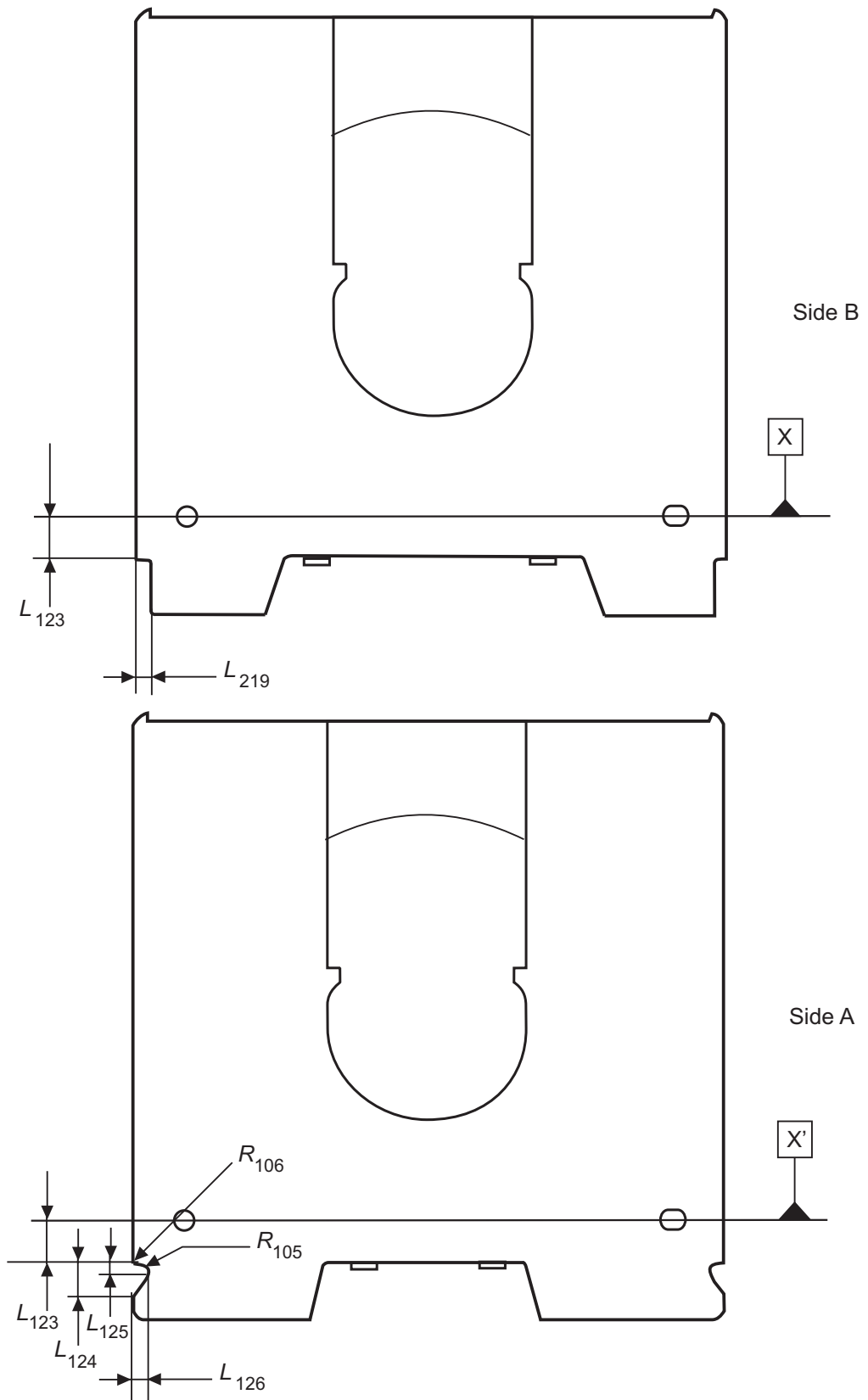

01-0060-A

Figure 38 - Mis-release protection function of the body of the case

12.2 Dimensions of the Type 7 case

The dimensions of the Type 7 case shall be measured in the test environment (see 7.1.1). The dimensions of the case in an operating environment (see 7.1.2) can be estimated from the dimensions specified in this clause.

12.2.1 Overall dimensions (Figure 39)

The total length of the case shall be

$$L_{301} = 91,0 \text{ mm} \pm 0,3 \text{ mm.}$$

The distance from the top of the case to Reference Plane X shall be

$$L_{302} = 77,0 \text{ mm} \begin{matrix} + 0,3 \text{ mm} \\ - 0,2 \text{ mm} \end{matrix}$$

with the width

$$L_{303} = 2,0 \text{ mm min.}$$

from the left-hand and right-hand edges of the case.

The distance from the bottom of the case to Reference Plane X shall be

$$L_{304} = 14,0 \text{ mm} \pm 0,2 \text{ mm.}$$

The total width of the case shall be

$$L_{305} = 89,0 \text{ mm} \pm 0,2 \text{ mm.}$$

The distance from the left-hand side of the case to Reference Plane Y shall be

$$L_{306} = 7,5 \text{ mm} \pm 0,2 \text{ mm.}$$

The distance from the right-hand side of the case to Reference Plane Y shall be

$$L_{307} = 81,5 \text{ mm} \pm 0,3 \text{ mm.}$$

The four corners shall be rounded off with a radius

$$R_{301} = 2,5 \text{ mm} \pm 0,1 \text{ mm}$$

In the zones delimited by

$$L_{308} = 6,0 \text{ mm}$$

from the left-hand and right-hand edges of the case, there shall be the continuous guide areas running from the top to Reference Plane X of the case, with a width

$$L_{309} = 0,7 \text{ mm min.}$$

The thickness of the case shall be

$$L_{310} = 5,4 \text{ mm} \begin{matrix} + 0,2 \text{ mm} \\ - 0,1 \text{ mm.} \end{matrix}$$

The eight long edges of the case shall be rounded off with a radius

$$R_{302} = 0,4 \text{ mm} \pm 0,1 \text{ mm.}$$

The flat area width of the top shall be

$$L_{311} = 0,5 \text{ mm max.}$$

12.2.2 Location hole (Figure 40)

The centre of the location hole shall coincide with the intersection of Reference Planes X, Y and Z.

The diameter of the hole shall be

$$D_{301} = 3,00 \text{ mm} \begin{matrix} + 0,05 \text{ mm} \\ - 0,00 \text{ mm} \end{matrix}$$

Its depth shall be

$$L_{312} = 0,8 \text{ mm min.}$$

The room below the location hole shall be free by

$$L_{313} = 4,0 \text{ mm min.}$$

below Reference Plane Z.

The diameter of the free room shall be at least equal to D_{301} .

The lead-in edges shall be rounded off with a radius

$$R_{303} = 0,3 \text{ mm} \begin{array}{l} + 0,1 \text{ mm} \\ - 0,0 \text{ mm} \end{array}$$

12.2.3 Alignment hole (Figure 40)

The centre of the alignment hole shall lie on the intersection of the Reference Planes X and Z at a distance

$$L_{314} = 74,0 \text{ mm} \pm 0,2 \text{ mm}$$

from Reference Plane Y.

The alignment hole shall have a substantially rectangular shape. Its dimensions shall be

$$L_{315} = 3,00 \text{ mm} \begin{array}{l} + 0,05 \text{ mm} \\ - 0,00 \text{ mm} \end{array}$$

$$L_{316} = 3,8 \text{ mm} \begin{array}{l} + 0,2 \text{ mm} \\ - 0,0 \text{ mm} \end{array}$$

Its depth shall be equal to L_{312} . The room below the alignment hole shall be free by at least L_{313} . The dimensions of the free room shall be at least L_{315} and L_{316} .

The lead-in edges shall be rounded off with a radius R_{303} .

12.2.4 Reference surfaces (Figure 40)

There shall be four reference surfaces S1, S2, S3 and S4 on Side B of the case.

Surfaces S1 and S2 shall be rectangular with a width

$$L_{317} = 6,0 \text{ mm min.}$$

with the centre located at reference plane X and these corners shall be rounded off with a radius

$$R_{304} = 3,0 \text{ mm min.}$$

originating the centre of the location hole for surface S1 and the centre of the alignment hole for surface S2.

Surfaces S3 and S4 shall be rectangular with dimensions

$$L_{318} = 5,7 \text{ mm max.}$$

$$L_{319} = 79,7 \text{ mm max.}$$

from Reference Plane Y and

$$L_{320} = 64,0 \text{ mm max.}$$

$$L_{321} = 72,0 \text{ mm min.}$$

from Reference Plane X.

12.2.5 Mis-insertion protection slots (Figure 41)

The case shall have three mis-insertion protection slots, two of them located symmetrically at the bottom side of the case and the other located at the top right side of the case.

The edge of the slots at the bottom side shall be at a distance

$$L_{323} = 7,0 \text{ mm} \pm 0,3 \text{ mm}$$

from Reference Plane X.

The slope start point measured from the edge shall be

$$L_{324} = 3,5 \text{ mm} \pm 0,2 \text{ mm}.$$

The slope end point measured from the edge shall be

$$L_{325} = 1,0 \text{ mm} \pm 0,1 \text{ mm}.$$

The depth measured from the edge of the case shall be

$$L_{326} = 2,0 \text{ mm} \pm 0,1 \text{ mm}.$$

The inside edge corner of the slots shall be rounded off with a radius

$$R_{305} = 0,5 \text{ mm max.}$$

The outside edge corner of the slots shall be rounded off with a radius

$$R_{306} = 0,3 \text{ mm} \pm 0,1 \text{ mm}.$$

The edge of the slot at the top right side shall be at a distance

$$L_{327} = 56,0 \text{ mm} \pm 0,3 \text{ mm}$$

from Reference Plane X.

It shall be defined by dimensions of L_{324} , L_{325} , L_{326} , R_{305} , R_{306} and a width

$$L_{328} = 4,5 \text{ mm} \pm 0,2 \text{ mm}$$

from Reference Plane Z.

12.2.6 Detents (Figure 41)

The case shall have two semi-circular, symmetrical detents intended for autoloading.

The positions and dimensions of these detents shall be

$$L_{427} = 3,0 \text{ mm} \pm 0,2 \text{ mm}$$

$$L_{428} = 0,5 \text{ mm} \pm 0,1 \text{ mm}$$

$$R_{307} = 1,5 \text{ mm} \pm 0,1 \text{ mm}$$

originating at

$$L_{329} = 63,5 \text{ mm} \pm 0,3 \text{ mm}$$

from Reference Plane X.

The width of the detents shall be

$$L_{330} = 3,7 \text{ mm} \pm 0,1 \text{ mm}$$

the centre of which shall be located at

$$L_{331} = 2,7 \text{ mm} \pm 0,1 \text{ mm}$$

from Reference Plane Z.

The outside edges of the detents shall be rounded off with a radius

$$R_{308} = 0,4 \text{ mm} \pm 0,1 \text{ mm}.$$

The bottom of the case shall have two symmetrical detents intended for clamping a cartridge in case of vertical use. Their dimensions shall be

$$L_{332} = 2,0 \text{ mm} \pm 0,1 \text{ mm}$$

$$L_{333} = 3,7 \text{ mm} \pm 0,2 \text{ mm}$$

$$L_{334} = 0,7 \text{ mm} \pm 0,1 \text{ mm}$$

The centre of one of these detents shall be at a distance

$$L_{335} = 5,5 \text{ mm} \pm 0,2 \text{ mm}$$

from Reference Plane Y.

The centre of the other shall be at a distance

$$L_{336} = 68,5 \text{ mm} \pm 0,2 \text{ mm}$$

from Reference Plane Y.

Both centres shall be at a distance

$$L_{337} = 2,7 \text{ mm} \pm 0,1 \text{ mm}$$

from Reference Plane Z.

12.2.7 Write-inhibit hole (Figure 42)

The case shall have a write-inhibit hole on Side B. The write-inhibit hole shall have a device for opening and closing the hole.

When writing and erasing on Side A of the disk are not allowed, the write-inhibit hole shall be open. It shall have a diameter

$$D_{302} = 2,5 \text{ mm min.}$$

The position of its centre on Side B shall be specified by

$$L_{338} = 11,5 \text{ mm} \pm 0,2 \text{ mm}$$

$$L_{339} = 13,0 \text{ mm} \pm 0,2 \text{ mm}$$

The hole shall extend below Reference Plane Z by

$$L_{340} = 4,0 \text{ mm min.}$$

with a diameter equal at least to D_{302} .

When writing and erasing of the disk are allowed, the write-inhibit hole shall be closed by the write protect device.

The write protect device shall not be recessed from Reference Plane Z by

$$L_{341} = 0,8 \text{ mm} \begin{matrix} + 0,2 \text{ mm} \\ - 0,1 \text{ mm} \end{matrix}$$

12.2.8 Sensor holes (Figure 42)

The case shall have three sensor holes on Side B. The set of holes on Side B of the case, A1, A2 and A3 pertains to Side A of the disk. The holes shall have a diameter of

$$D_{303} = 2,5 \text{ mm min.}$$

and the positions of their centres shall be specified by L_{338} and

$$L_{342} = 2,0 \text{ mm} \pm 0,2 \text{ mm}$$

$$L_{343} = 3,0 \text{ mm} \pm 0,2 \text{ mm}$$

$$L_{344} = 8,0 \text{ mm} \pm 0,2 \text{ mm.}$$

The room below the holes shall be free by

$$L_{345} = 4,0 \text{ mm min.}$$

above Reference Plane Z.

The diameter of the free room shall be at least equal to D_{303} . The holes shall be permitted to extend through Side A.

When a hole for Side A of the disk is closed, the closure shall not be recessed from Reference Plane Z by

$$L_{346} = 0,8 \text{ mm} \begin{matrix} + 0,2 \text{ mm} \\ - 0,1 \text{ mm} \end{matrix}$$

The sensor hole A1 shall indicate whether a disk has been taken out once or not. Originally, the sensor hole A1 shall be closed and once a disk has been taken out of the case, this hole shall be opened and never closed again.

The functions identified by the states of the sensor holes are specified in Table 7.

Table 7 - Use of the sensor holes

Sensor hole	Function		State
	Closed	Open	
A1	The original disk has not been taken out	The original disk has been taken out, or a disk has been put in	Closed / Open
A2	Cartridge detection	Not permitted	Closed
A3	Reserved for future standardization		Closed

12.2.9 Spindle and head window (Figure 43)

The dimensions of the window shall be referenced to a centreline, located at a distance

$$L_{347} = 37,0 \text{ mm} \pm 0,1 \text{ mm}$$

from Reference Plane Y. The width of the window from the top of the case to

$$L_{348} = 40,0 \text{ mm max.}$$

shall be

$$L_{349} = 13,0 \text{ mm} \pm 0,1 \text{ mm}$$

and

$$L_{350} = 13,0 \text{ mm} \pm 0,1 \text{ mm.}$$

The top of the window shall be specified by

$$R_{309} = 40,7 \text{ mm min.}$$

originating from L_{347} and

$$L_{351} = 29,0 \text{ mm} \pm 0,1 \text{ mm.}$$

The width of the window with the projection portion shall be given by

$$L_{352} = 10,0 \text{ mm min.}$$

and

$$L_{353} = 10,0 \text{ mm min.}$$

The width of the window at L_{351} shall be given by

$$L_{354} = 13,7 \text{ mm} \begin{matrix} + 0,2 \text{ mm} \\ - 0,0 \text{ mm} \end{matrix}$$

and

$$L_{355} = 13,7 \text{ mm} \begin{matrix} + 0,2 \text{ mm} \\ - 0,0 \text{ mm.} \end{matrix}$$

The bottom and the projection portion of the window shall be the arc specified by a radius

$$R_{310} = 14,0 \text{ mm min.}$$

and its centre shall be defined by the intersection of L_{347} and L_{351} .

The area bounded by R_{309} and top of the case shall be recessed from Reference Plane Z by

$$L_{356} = 1,3 \text{ mm min.}$$

$$L_{357} = 4,1 \text{ mm max.}$$

over the width of the window.

12.2.10 Shutter shape (Figure 44)

The case shall have a spring-loaded shutter completely covering the spindle and head windows when the case is not inside a drive. The shutter shall be free to slide in a recessed area of the case. The shutter shall not protrude beyond Reference Planes Z or the surface of Side A by more than 0,15 mm.

The shutter shall have an opener slot and an opener edge against which the shutter opener of the drive can push to open the shutter. The shutter can be moved toward the left corresponding to the shutter opener mechanism.

The top of the shutter shall be located at

$$L_{358} = 77,0 \text{ mm} \begin{matrix} + 0,3 \text{ mm} \\ - 0,2 \text{ mm} \end{matrix}$$

from Reference Plane X.

The opener slot shall be defined by the dimensions

$$L_{359} = 5,0 \text{ mm} \pm 0,1 \text{ mm}$$

$$L_{360} = 2,2 \text{ mm} \begin{matrix} + 0,3 \text{ mm} \\ - 0,0 \text{ mm.} \end{matrix}$$

$$L_{361} = 2,0 \text{ mm} \pm 0,1 \text{ mm}$$

and its centre shall be defined by the intersection of

$$L_{362} = 37,0 \text{ mm} \pm 0,2 \text{ mm}$$

from Reference Plane Y and

$$L_{363} = 2,7 \text{ mm} \pm 0,1 \text{ mm}$$

from Reference Plane Z when the shutter is closed.

The outside edge corners shall be rounded off with a radius

$$R_{311} = 0,4 \text{ mm max.}$$

The inside edge corners shall be rounded off with a radius

$$R_{312} = 0,4 \text{ mm max.}$$

The opener edge shall be defined by the dimensions

$$L_{429} = 2,2 \text{ mm min.}$$

$$L_{367} = 2,2 \text{ mm} \pm 0,2 \text{ mm}$$

and its centre shall be located at L_{363} .

When the shutter is closed, the opener edge shall be at

$$L_{364} = 50,7 \text{ mm} \pm 0,3 \text{ mm}$$

from Reference Plane Y.

The case shall have an opener guide through which the opener edge can be pushed by the shutter opener of a drive.

In projective figure viewed from the case side shall be defined by L_{367} and a width of

$$L_{365} = 2,4 \text{ mm} \pm 0,2 \text{ mm}$$

with the centre located at

$$L_{366} = 2,7 \text{ mm} \pm 0,1 \text{ mm}$$

from Reference Plane Z.

The corner of the opener guide shall be rounded off with a radius

$$R_{313} = 0,4 \text{ mm} \pm 0,1 \text{ mm}.$$

12.2.11 Path for shutter opener (Figure 45)

When the left-hand edge position of the opener slot is

$$L_{368} = 6,3 \text{ mm},$$

the shutter shall be open at

$$L_{369} = 12,9 \text{ mm min.}$$

and

$$L_{370} = 13,7 \text{ mm min.}$$

from L_{347} .

When the position of the opener edge is

$$L_{371} = 22,5 \text{ mm},$$

the shutter shall be open at L_{369} and L_{370} .

The left-hand edge position of the opener slot shall be

$$L_{372} = 5,9 \text{ mm max.}$$

and the position of the opener edge shall be

$$L_{373} = 22,1 \text{ mm max.}$$

when the shutter completely moves up.

12.2.12 Label areas (Figure 46)

The case shall have two label areas on Side A. Their dimensions shall be

$$L_{374} = 7,1 \text{ mm} \pm 0,2 \text{ mm}$$

$$L_{375} = 5,0 \text{ mm} \pm 0,2 \text{ mm}$$

$$L_{376} = 8,0 \text{ mm} \pm 0,2 \text{ mm}$$

$$L_{377} = 66,0 \text{ mm} \pm 0,3 \text{ mm}$$

$$L_{378} = 14,0 \text{ mm} \pm 0,2 \text{ mm}$$

$$L_{379} = 72,0 \text{ mm} \pm 0,3 \text{ mm}$$

$$L_{380} = 77,0 \text{ mm} \pm 0,3 \text{ mm}$$

$$L_{381} = 55,0 \text{ mm} \pm 0,3 \text{ mm}$$

$$R_{314} = 1,0 \text{ mm} \pm 0,2 \text{ mm}$$

The label areas shall be recessed by 0,2 mm min.

12.2.13 Identification marks for Sides A and B (Figure 47)

Side A and Side B shall be identified by an identification mark provided on a concave part on Side A and Side B, respectively. On Side A, this concave part presents a small round projection, on Side B two such projections are provided. The position and dimensions of these identification marks shall be as follows.

Side A

$$R_{315} = 0,4 \text{ mm} \begin{array}{l} + 0,1 \text{ mm} \\ - 0,0 \text{ mm} \end{array}$$

$$L_{383} = 0,4 \text{ mm} \begin{matrix} + 0,1 \text{ mm} \\ - 0,0 \text{ mm} \end{matrix}$$

$$L_{384} = 10,2 \text{ mm} \pm 0,3 \text{ mm}$$

$$L_{385} = 37,0 \text{ mm} \pm 0,4 \text{ mm}$$

$$L_{386} = 0,5 \text{ mm} \begin{matrix} + 0,1 \text{ mm} \\ - 0,0 \text{ mm} \end{matrix}$$

$$L_{387} = 9,0 \text{ mm} \pm 1,0 \text{ mm}$$

$$L_{388} = 5,0 \text{ mm} \pm 0,5 \text{ mm}$$

Side B

$$R_{315} = 0,4 \text{ mm} \begin{matrix} + 0,1 \text{ mm} \\ - 0,0 \text{ mm} \end{matrix}$$

$$L_{383} = 0,4 \text{ mm} \begin{matrix} + 0,1 \text{ mm} \\ - 0,0 \text{ mm} \end{matrix}$$

$$L_{384} = 10,2 \text{ mm} \pm 0,3 \text{ mm}$$

$$L_{385} = 37,0 \text{ mm} \pm 0,4 \text{ mm}$$

$$L_{386} = 0,5 \text{ mm} \begin{matrix} + 0,1 \text{ mm} \\ - 0,0 \text{ mm} \end{matrix}$$

$$L_{387} = 9,0 \text{ mm} \pm 1,0 \text{ mm}$$

$$L_{388} = 5,0 \text{ mm} \pm 0,5 \text{ mm}$$

$$L_{389} = 3,0 \text{ mm} \pm 0,3 \text{ mm}$$

12.2.14 Disk holder and body (Figure 48)

The case shall consist of a body and a disk holder to allow the removal or replacement of the disk. In the original condition, the disk holder shall be locked in the body and the sensor holes A1 closed.

When the status of the sensor holes A1 changes from closed to open, the disk holder holding a disk can be removed from the case. Once the status of the sensor holes A1 changes from closed to open, the open status is kept and cannot be changed back to the closed status. The body and the disk holder shall be formed so as not damaging the read-out side of the disk.

The disk holder shall have a pair of holding arms with upper and lower flanges, a grip, a pair of lock levers with a lock portion and a pair of detents. A disk shall be supported among the holding arms and the grip. The disk shall not be removed from the disk holder by a releasing force of 0,35 N or less.

The dimensions of the disk holder shall be as follows, using the three orthogonal reference plane A, B and C.

Arm

$$L_{390} = 22,0 \text{ mm} \pm 0,2 \text{ mm}$$

$$L_{391} = 79,0 \text{ mm} \pm 0,2 \text{ mm}$$

$$L_{392} = 84,8 \text{ mm} \pm 0,1 \text{ mm}$$

$$L_{393} = 74,0 \text{ mm} \pm 0,2 \text{ mm}$$

$$L_{394} = 19,5 \text{ mm} \pm 0,2 \text{ mm}$$

$$L_{395} = 70,0 \text{ mm} \pm 0,2 \text{ mm}$$

$$L_{396} = 70,0 \text{ mm min. (The upper and lower flanges shall not lie inside } L_{396}\text{)}$$

$$R_{316} = 38,5 \text{ mm} \begin{array}{l} + 0,1 \text{ mm} \\ - 0,0 \text{ mm} \end{array}$$

$$R_{317} = 40,7 \text{ mm} \begin{array}{l} + 0,1 \text{ mm} \\ - 0,0 \text{ mm} \end{array}$$

$$R_{318} = 42,4 \text{ mm} \pm 0,1 \text{ mm}$$

$$L_{397} = 3,7 \text{ mm} \pm 0,05 \text{ mm}$$

$$L_{398} = 2,9 \text{ mm} \pm 0,1 \text{ mm}$$

$$L_{399} = 3,1 \text{ mm} \pm 0,05 \text{ mm}$$

Grip

$$L_{400} = 43,0 \text{ mm} \pm 0,1 \text{ mm}$$

$$L_{401} = 35,5 \text{ mm} \pm 0,1 \text{ mm}$$

$$L_{402} = 32,0 \text{ mm} \begin{array}{l} + 0,0 \text{ mm} \\ - 0,2 \text{ mm} \end{array}$$

$$L_{403} = 29,0 \text{ mm} \begin{array}{l} + 0,0 \text{ mm} \\ - 0,2 \text{ mm} \end{array}$$

$$L_{404} = 0,7 \text{ mm} \begin{array}{l} + 0,0 \text{ mm} \\ - 0,2 \text{ mm} \end{array}$$

$$L_{405} = 22,0 \text{ mm} \begin{array}{l} + 0,0 \text{ mm} \\ - 0,2 \text{ mm} \end{array}$$

$$L_{406} = 19,0 \text{ mm} \begin{array}{l} + 0,0 \text{ mm} \\ - 0,2 \text{ mm} \end{array}$$

$$R_{319} = 0,5 \text{ mm} \pm 0,1 \text{ mm}$$

$$R_{320} = 1,2 \text{ mm} \pm 0,1 \text{ mm}$$

$$L_{407} = 4,5 \text{ mm} \pm 0,1 \text{ mm}$$

$$L_{408} = 3,1 \text{ mm} \pm 0,05 \text{ mm}$$

$$L_{409} = 5,4 \text{ mm} \pm 0,05 \text{ mm}$$

$$L_{410} = 3,0 \text{ mm} \begin{array}{l} + 0,2 \text{ mm} \\ - 0,0 \text{ mm} \end{array}$$

$$L_{411} = 20,0 \text{ mm} \pm 0,1 \text{ mm}$$

$$L_{412} = 12,0 \text{ mm} \pm 0,1 \text{ mm}$$

$$L_{413} = 0,1 \text{ mm} \begin{array}{l} + 0,1 \text{ mm} \\ - 0,0 \text{ mm} \end{array}$$

$$L_{414} = 0,5 \text{ mm} \begin{array}{l} + 0,1 \text{ mm} \\ - 0,0 \text{ mm} \end{array}$$

$$L_{415} = 1,9 \text{ mm} \pm 0,1 \text{ mm}$$

Lock lever

$$L_{416} = 85,0 \text{ mm} \pm 0,1 \text{ mm}$$

$$L_{417} = 34,5 \text{ mm} \pm 0,1 \text{ mm}$$

$$L_{418} = 1,0 \text{ mm} \pm 0,1 \text{ mm}$$

$$L_{419} = 1,0 \text{ mm} \begin{array}{l} + 0,0 \text{ mm} \\ - 0,3 \text{ mm} \end{array}$$

$$L_{420} = 1,85 \text{ mm} \begin{array}{l} + 0,1 \text{ mm} \\ - 0,3 \text{ mm} \end{array}$$

$$L_{421} = 4,0 \text{ mm} \pm 0,2 \text{ mm}$$

$$L_{422} = 27,8 \text{ mm} \pm 0,2 \text{ mm}$$

$$L_{423} = 36,0 \text{ mm} \pm 0,1 \text{ mm}$$

$$L_{424} = 1,0 \text{ mm} \pm 0,1 \text{ mm}$$

Detent

$$L_{425} = 20,0 \text{ mm} \pm 0,1 \text{ mm}$$

$$R_{321} = 1,5 \text{ mm} \pm 0,1 \text{ mm}$$

The body shall be formed to engage the lock portions and the grip of the disk holder, as an example shown in Annex J.

The body shall have the mis-release protection function for the disk holder with dimensions of L_{323} , L_{324} , L_{325} , L_{326} , R_{305} , R_{306} and

$$L_{426} = 2,7 \text{ mm min.}$$

as shown in Figure 49.

The body shall be formed so as to enable to set the disk holder with its elastic deformation in the condition of entering the disk in the body.

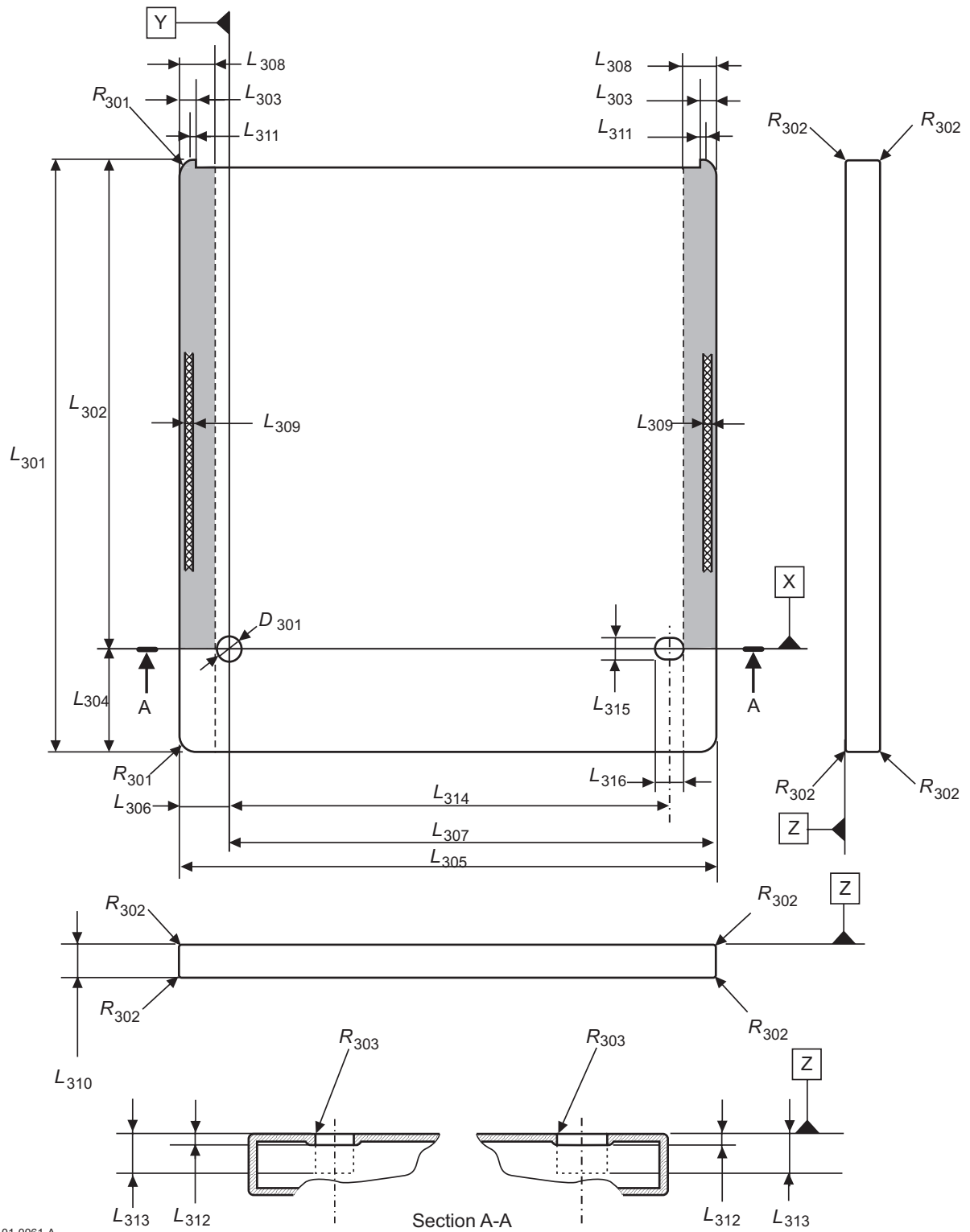

01-0061-A

Figure 39 - Overall dimensions

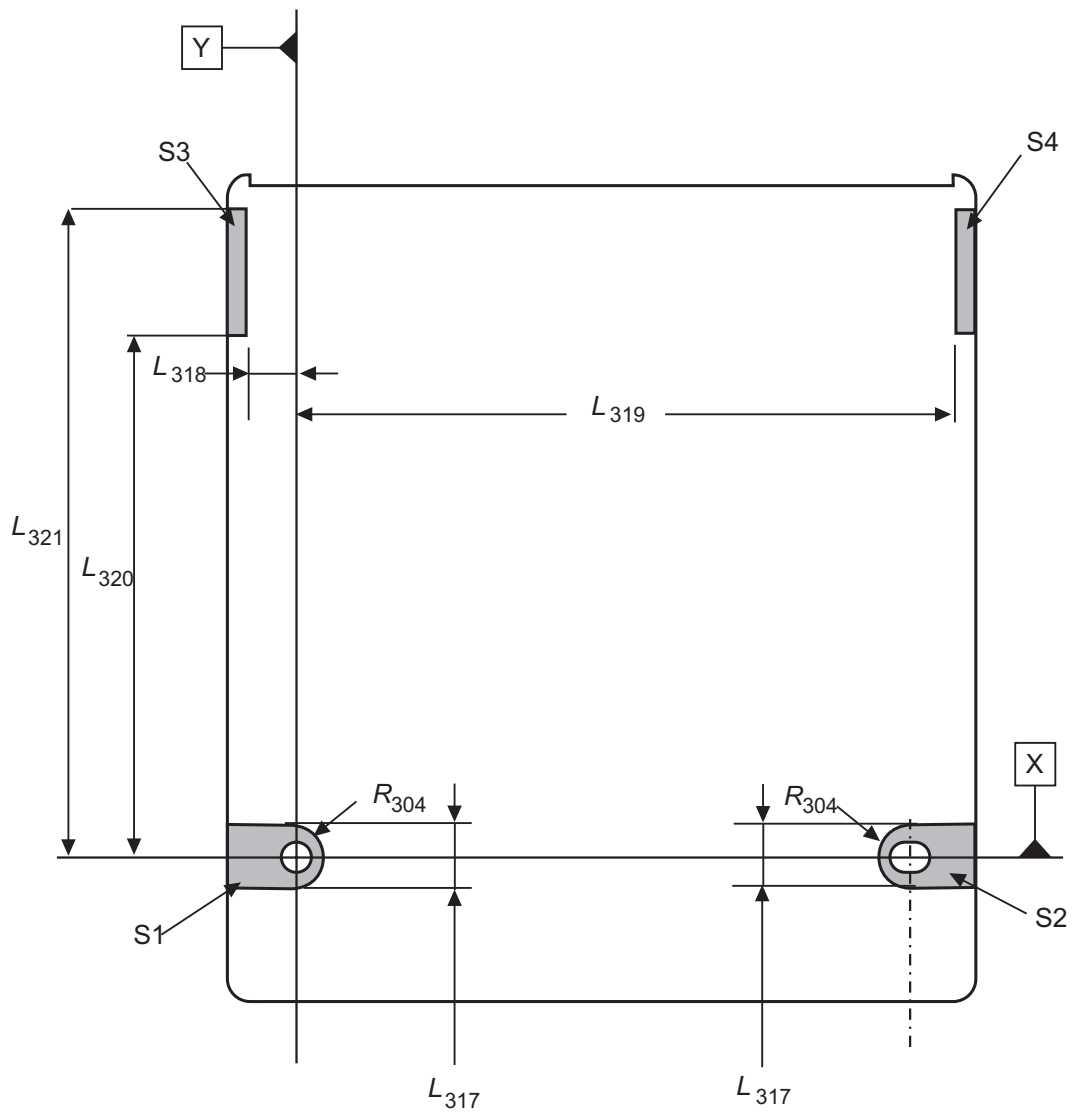

01-0062-A

Figure 40 - Reference surfaces

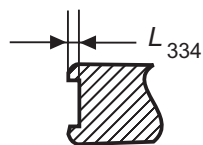
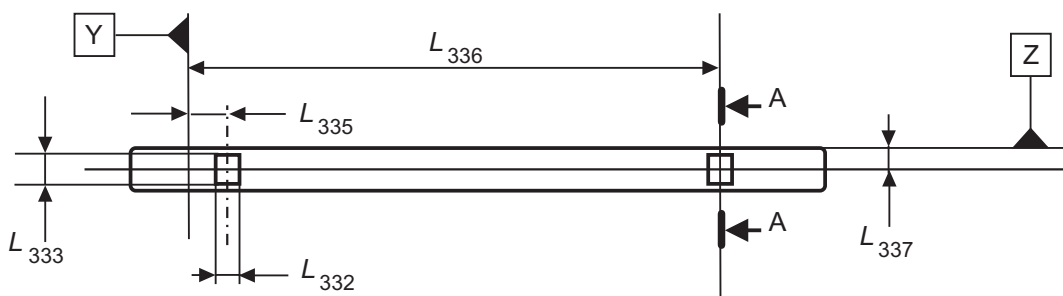
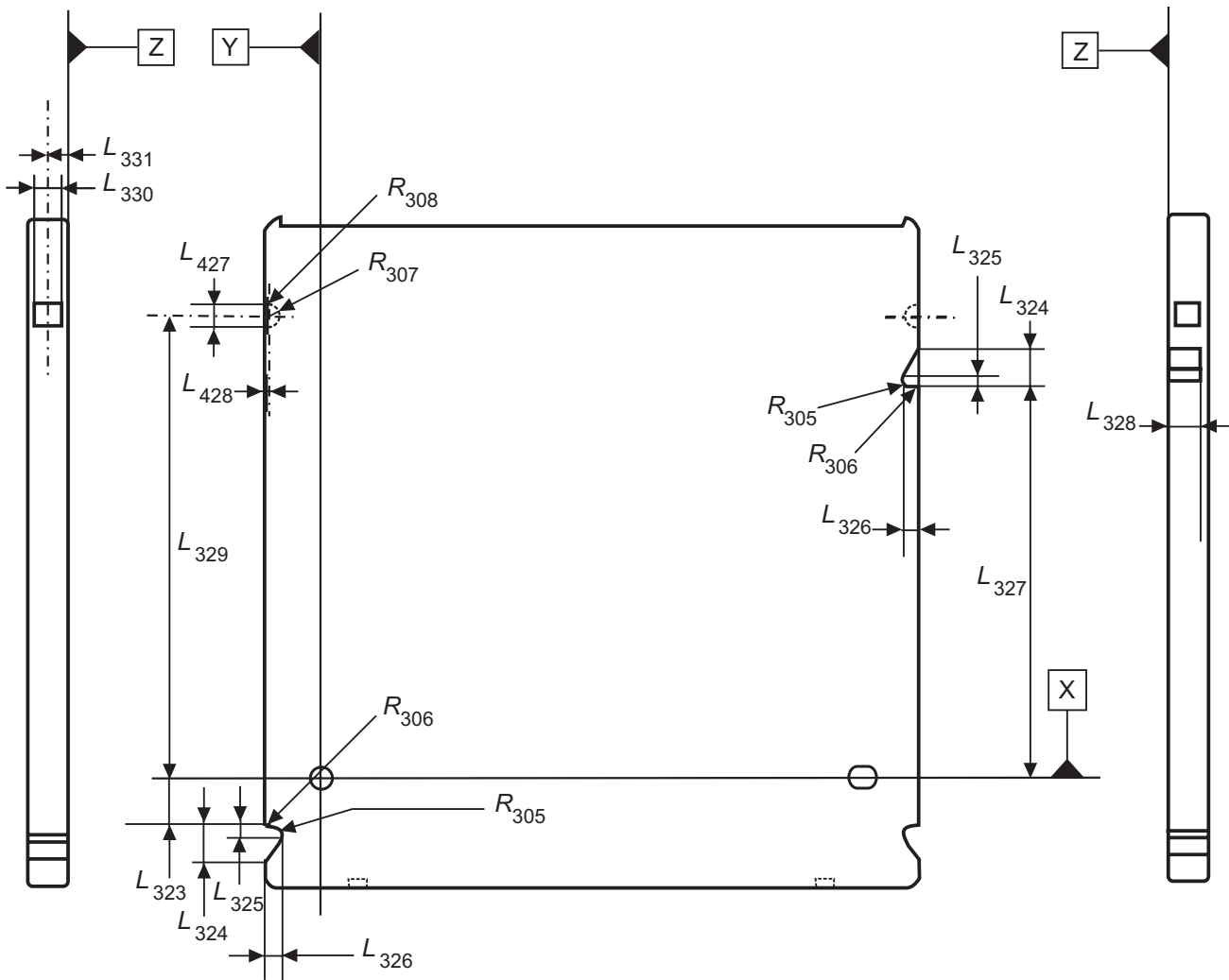

Section A-A

01-0063-A

Figure 41 - Mis-insertion protection slot and detents

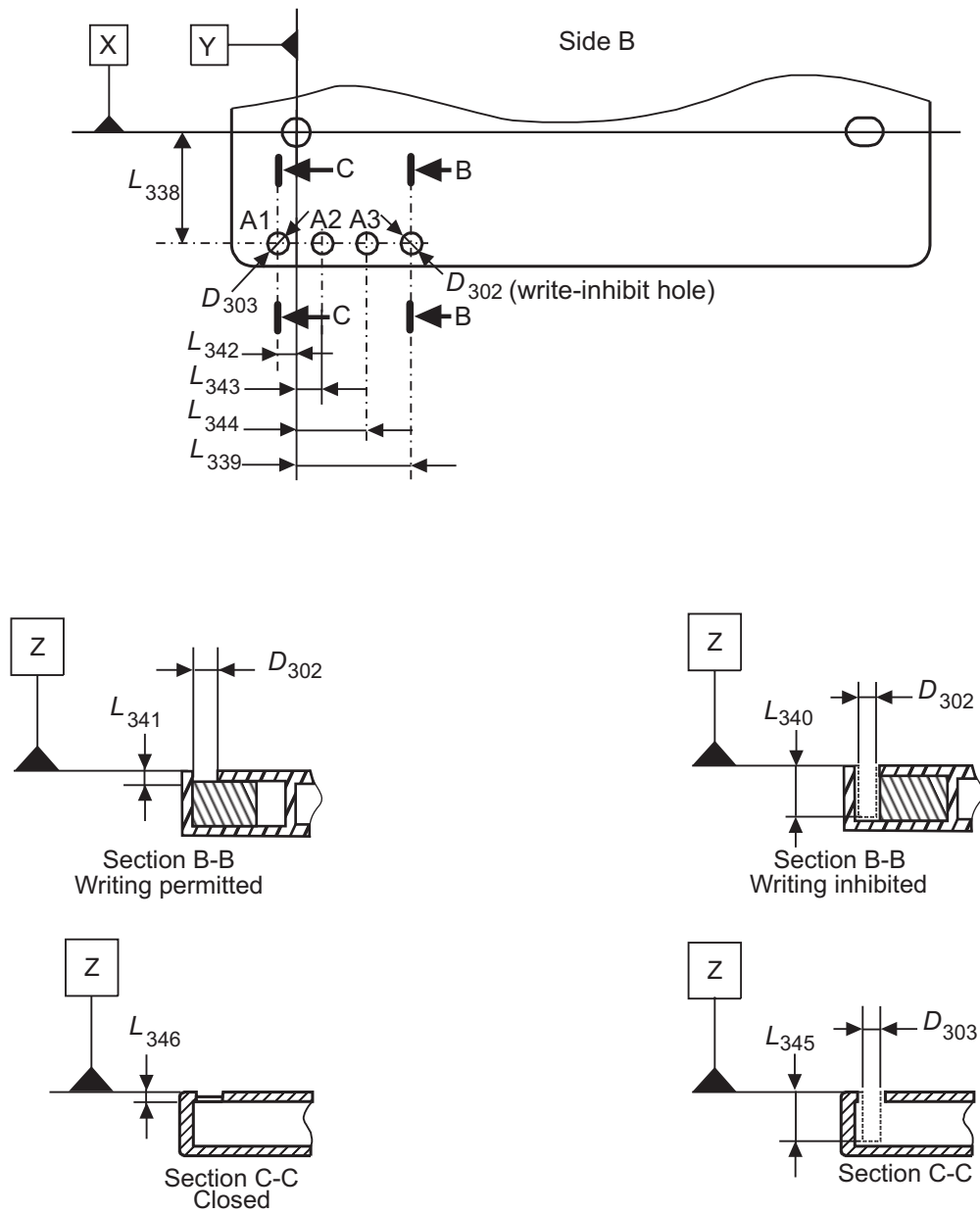

01-0064-A

Figure 42 - Write-inhibit hole and sensor holes

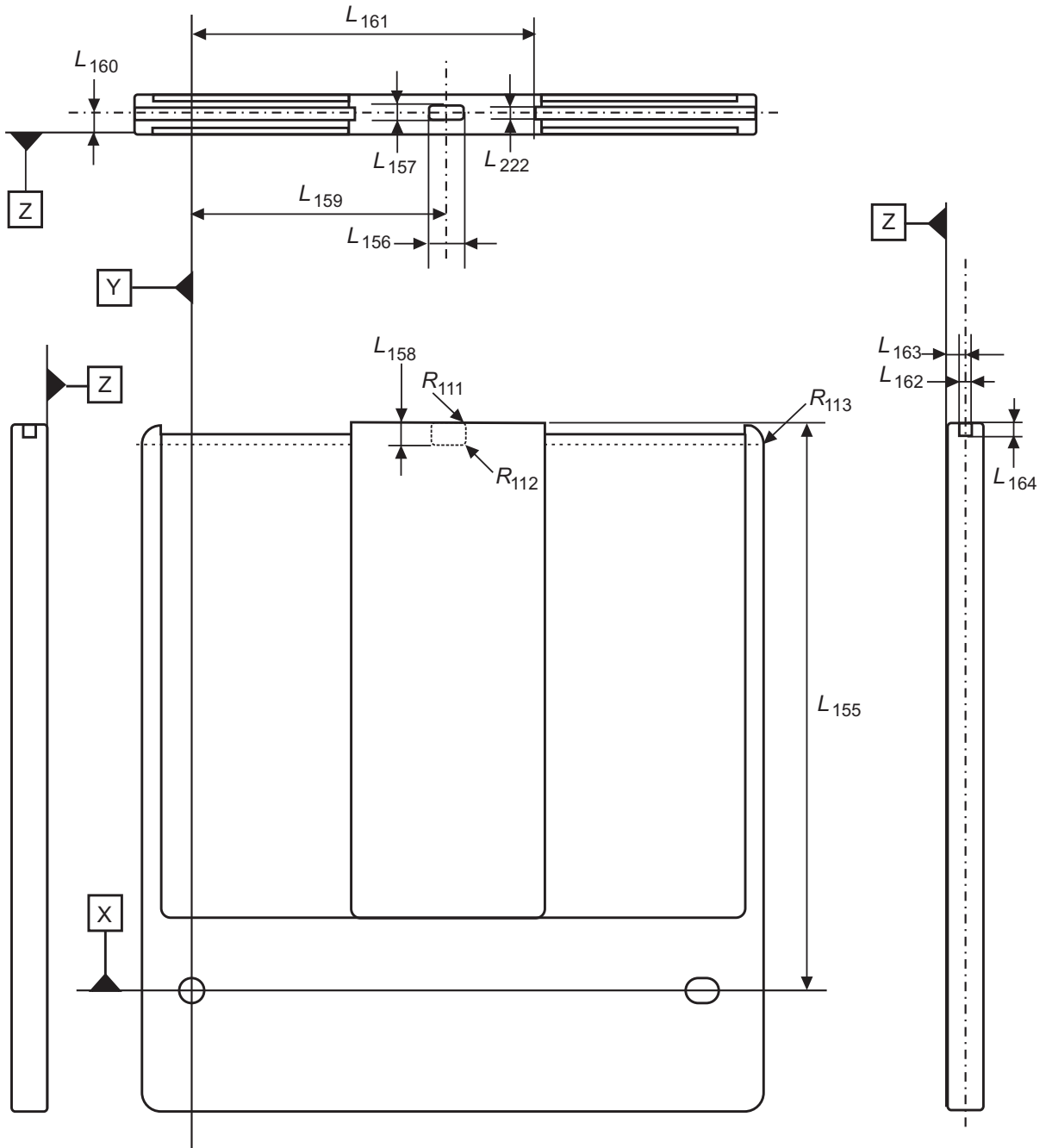

01-0055-A

Figure 43 - Spindle and head window

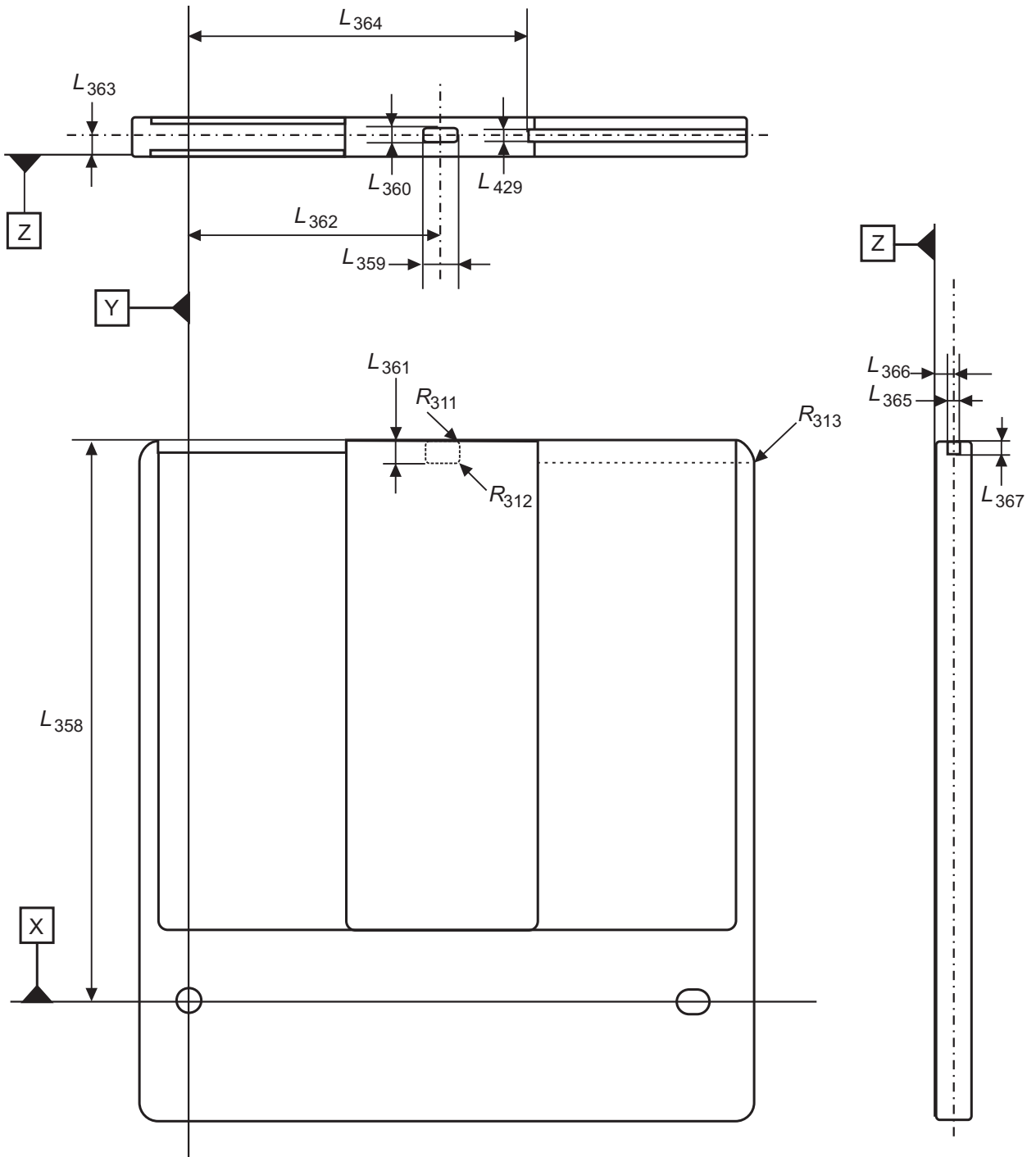

01-0066-A

Figure 44 - Shape of the shutter

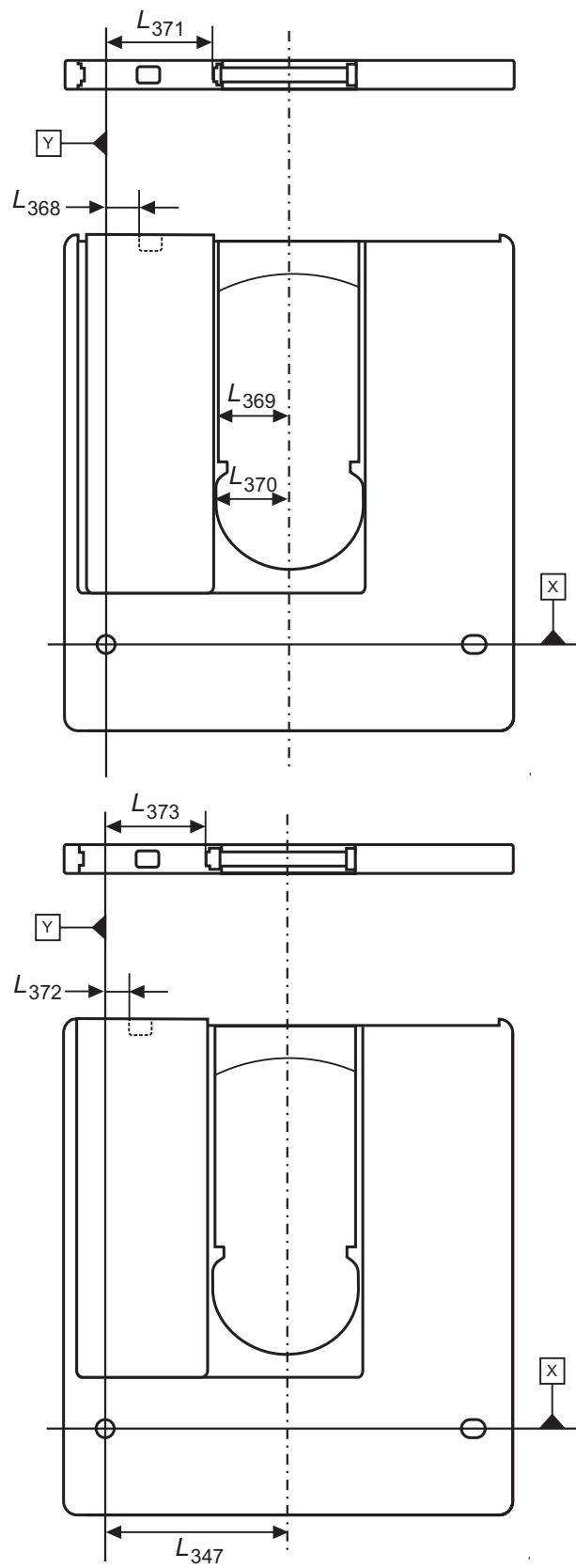

01-0067-A

Figure 45 - Shutter in just open position (top view) and maximum open position (bottom view)

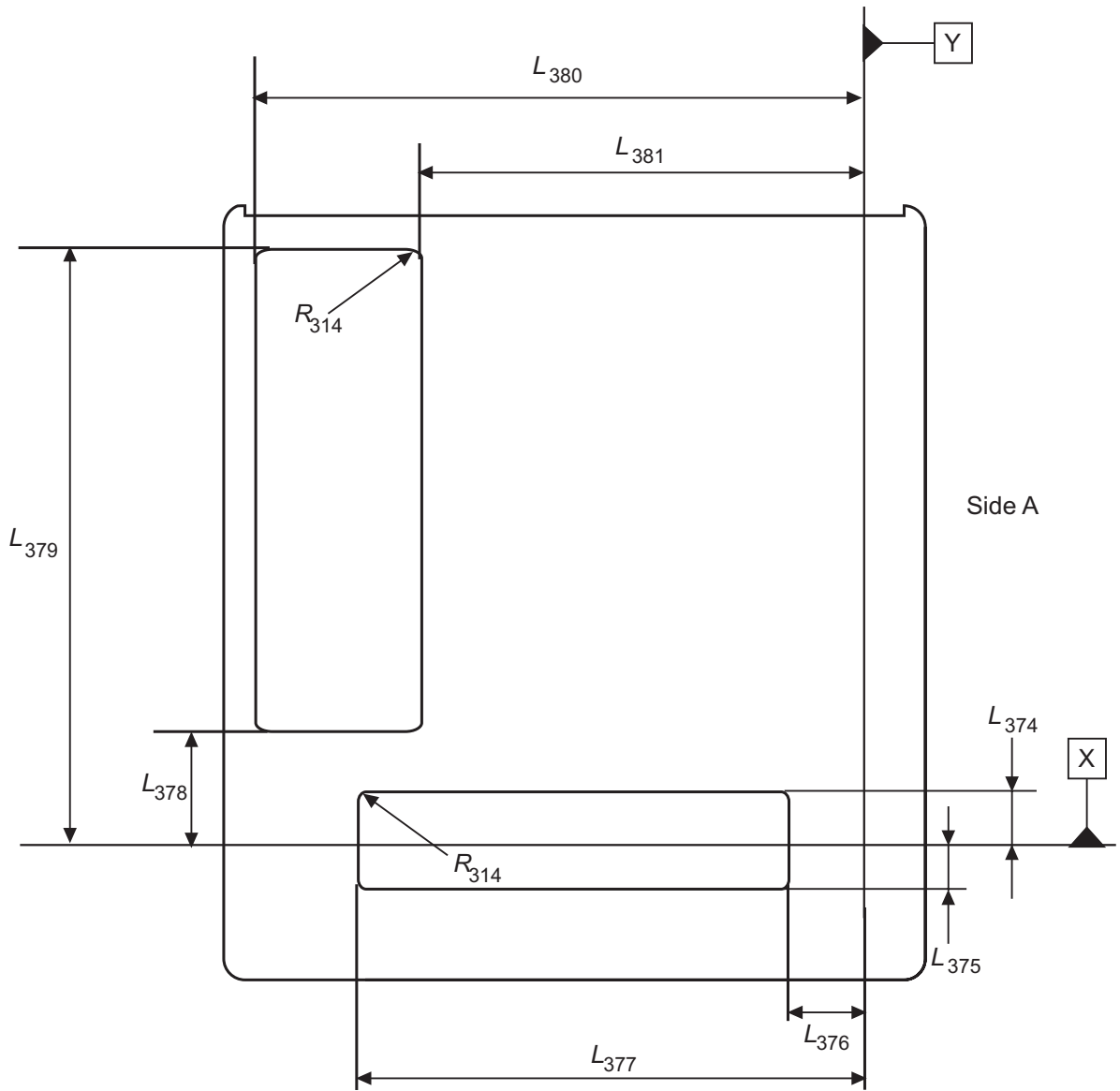

01-0068-A

Figure 46 - Label areas

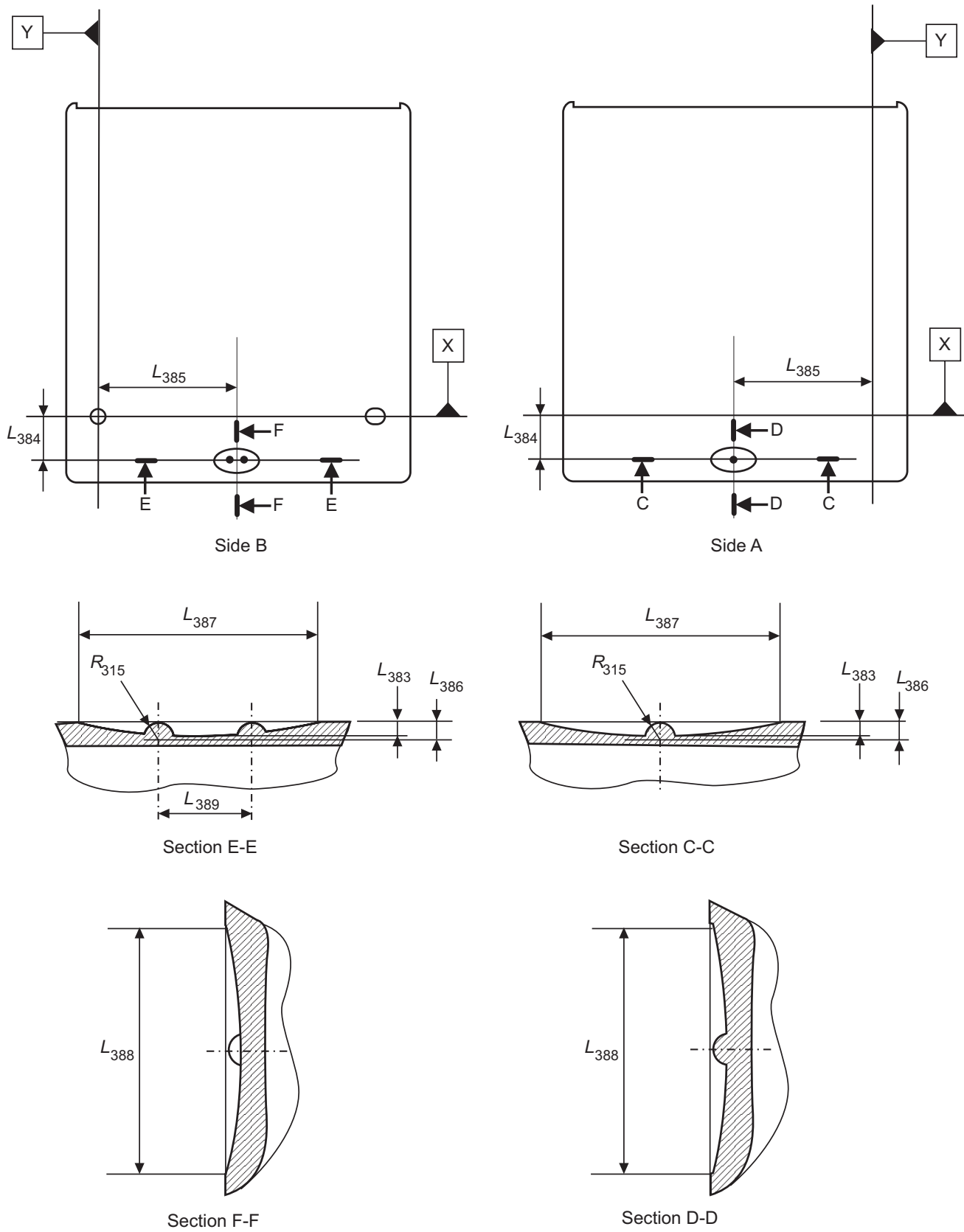

01-0069-A

Figure 47 - Identification mark of Side A and B

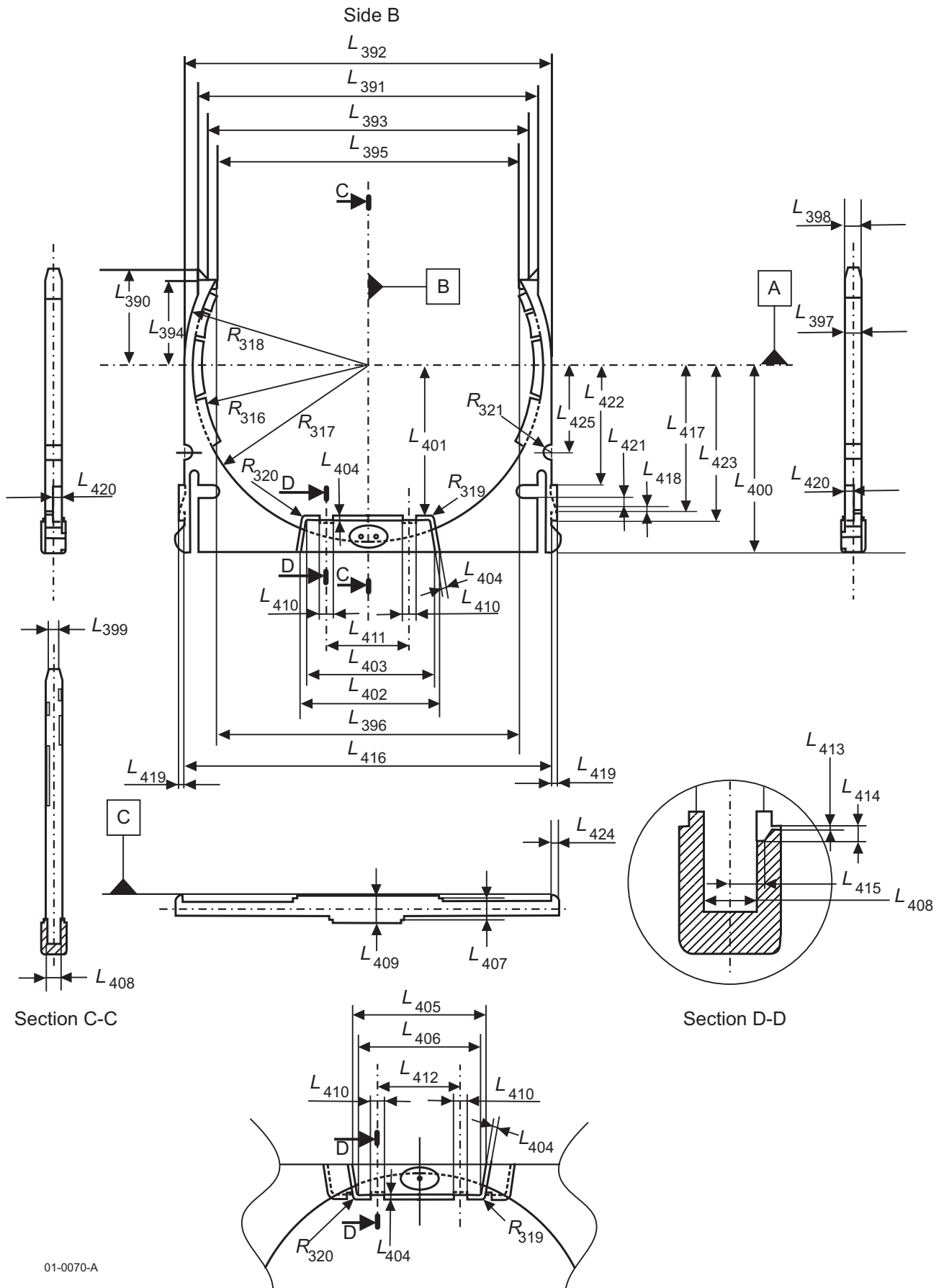
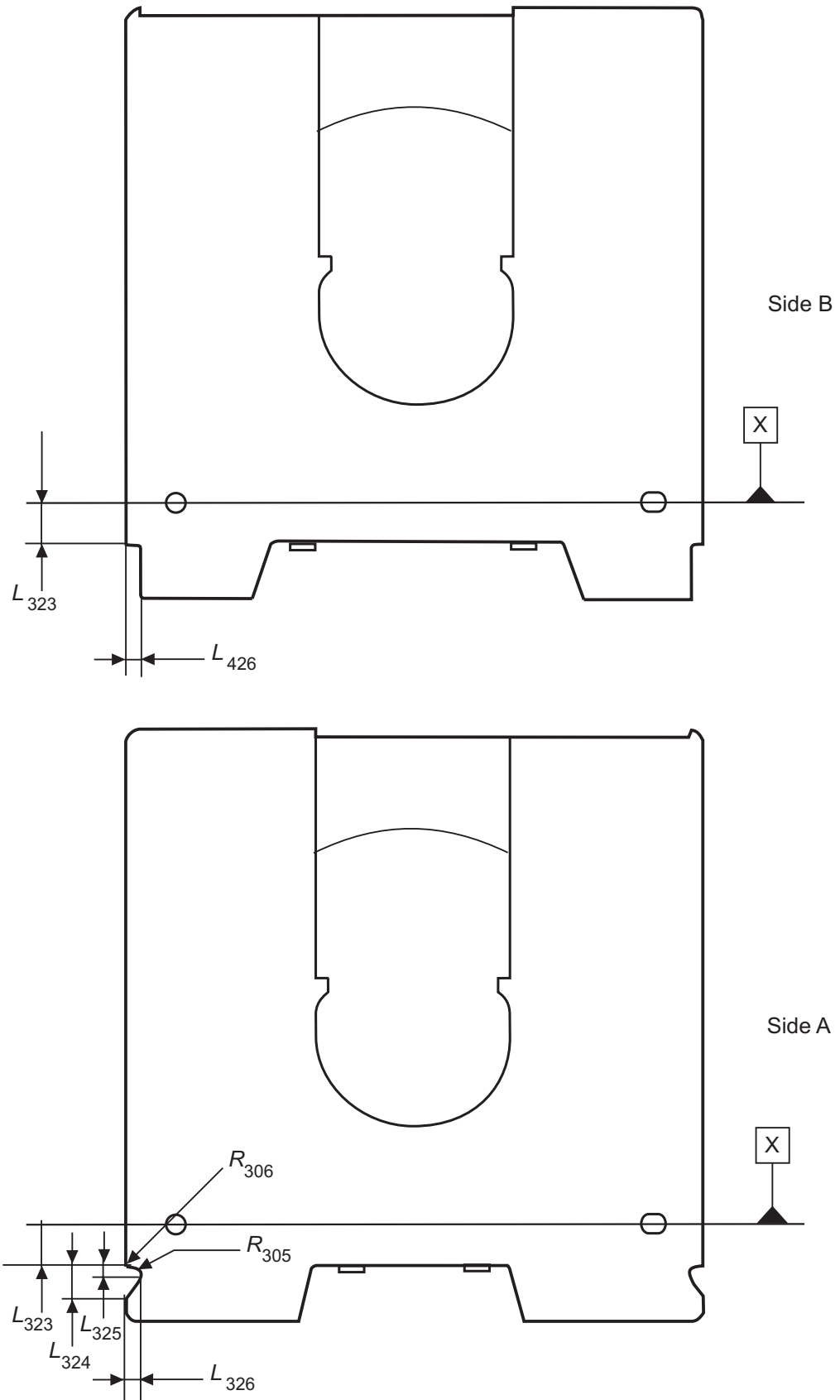

Figure 48 - Disk holder shape



01-0071-A

Figure 49 - Mis-release protection function of body of the case

12.3 Dimensions of the Type 8 case

The dimensions of the Type 8 case shall be measured in the test environment (see 7.1.1). The dimensions of the case in an operating environment (see 7.1.2) can be estimated from the dimensions specified in this clause.

The dimensions of the case are identical with those of the Type 6 case. See 12.1.

The following clauses specify different features from the Type 6 case.

12.3.1 Sensor holes

The functions identified by the states of the sensor holes are specified in Table 8.

Table 8 - Use of the sensor holes

Sensor hole	Function		State
	Closed	Open	
A1	Not permitted	There may or may not be a disk within the case	Open
A2	Cartridge detection	Not permitted	Closed
A3	Reserved for future standardization		Closed
B1	Not permitted	There may or may not be a disk within the case	Open
B2	Cartridge detection	Not permitted	Closed
B3	Reserved for future standardization		Closed

12.3.2 Disk holder and body

The case shall have a body and a disk holder to allow the insertion or removal of a disk. The disk holder can be taken out of and set in the body freely.

12.4 Dimensions of the Type 9 case

The dimensions of the Type 9 case shall be measured in the test environment (see 7.1.1). The dimensions of the case in an operating environment (see 7.1.2) can be estimated from the dimensions specified in this clause.

The dimensions of the case are identical with those of the Type 7 case. See 12.2.

The following clauses specify different features from the Type 7 case.

12.4.1 Sensor holes

The functions identified by the states of the sensor holes are specified in Table 9.

Table 9 - Use of the sensor holes

Sensor hole	Function		State
	Closed	Open	
A1	Not permitted	There may or may not be a disk within the case	Open
A2	Cartridge detection	Not permitted	Closed
A3	Reserved for future standardization		Closed

12.4.2 Disk holder and body

The case shall have a body and a disk holder to allow the insertion or removal of a disk. The disk holder can be taken out of and set in the body freely.

13 Mechanical characteristics

13.1 Material

The case shall be constructed from any suitable materials such that it meets the requirements of this Standard.

13.2 Mass

The mass of the case without the disk shall not exceed 40 g.

13.3 Edge distortion

The cartridge shall meet the requirement of the edge distortion test defined in Annex E.

13.4 Compliance

The case shall meet the requirement of the compliance (flexibility) test defined in Annex F.

13.5 Shutter opening force

The spring force on the shutter shall be such that the force required to open the shutter does not exceed 1,75 N while the vertical force of 2,5 N is applied to the shutter top surface (see Annex G). It shall be sufficiently strong to close a free-sliding shutter, irrespective of the orientation of the case.

14 Interface between the case used as cartridge and a drive

14.1 Capture cylinder (Figure 50)

The capture cylinder is defined as the volume within which the spindle can expect the centre of the disk hole to be, just prior to capture, and with the cartridge constrained as specified in 13.4. The size of the cylinder defines the permissible play of the disk inside its cavity in the case. The cylinder is referred to perfectly located and perfectly sized alignment and location pins in the drive; it includes the tolerances of those dimensions of the case and the disk which are between the two pins mentioned and the centre of the disk.

The bottom of the cylinder shall be parallel to Reference Plane Z, and shall be located at a distance

$$L_{501} = 1,1 \text{ mm min.}$$

above Reference Plane Z. The top of the cylinder is located at a distance

$$L_{502} = 3,6 \text{ mm max.}$$

from Reference Plane Z. The diameter of the cylinder shall be

$$D_{501} = 2,8 \text{ mm max.}$$

and its centre shall be given by the nominal values of L_{145} and L_{149} of Type 6 case or Type 8 case, or L_{347} and L_{351} of Type 7 case or Type 9 cases, in the drive.

14.2 Inner dimensions of the case (Figure 51)

The inner space of the disk shall be such that the disk is not in contact with the case during operation. The inner shape of the case shall meet the following requirements.

$$L_{503} = 1,7 \text{ mm max.}$$

$$L_{504} = 3,9 \text{ mm min.}$$

measured from Reference Plane Z and

$$L_{505} = 0,3 \text{ mm} \begin{array}{l} + 0,1 \text{ mm} \\ - 0,0 \text{ mm} \end{array}$$

$$L_{506} = 0,3 \text{ mm} \begin{array}{l} + 0,1 \text{ mm} \\ - 0,0 \text{ mm} \end{array}$$

from the surfaces of L_{503} and L_{504} respectively and

$$R_{501} = 15,5 \text{ mm max.}$$

$$R_{502} = 40,7 \text{ mm min.}$$

from a centre given by the nominal values of L_{145} and L_{149} of Type 6 case or Type 8 case, or L_{347} and L_{351} of Type 7 or Type 9 cases.

15 Orientation of the disk in the case

15.1 Two-sided disk (Type 2S) in case Types 6 and 8

The disk surfaces are defined as Side A and Side B. Sides A and B of the case are identical as far as the features specified in this Standard are concerned. The two-sided disk (Type 2S) has no specific orientation in the case. Therefore, references to Sides A and B of the case can be changed to B and A respectively.

15.2 One-sided disk (Type 1S) in case Types 7 and 9

A one-sided disk (Type 1S) has only one functional entrance surface defined as Side A. The disk shall be oriented in the case so that when Side A of the case faces upwards, Side A of the disk faces downwards.

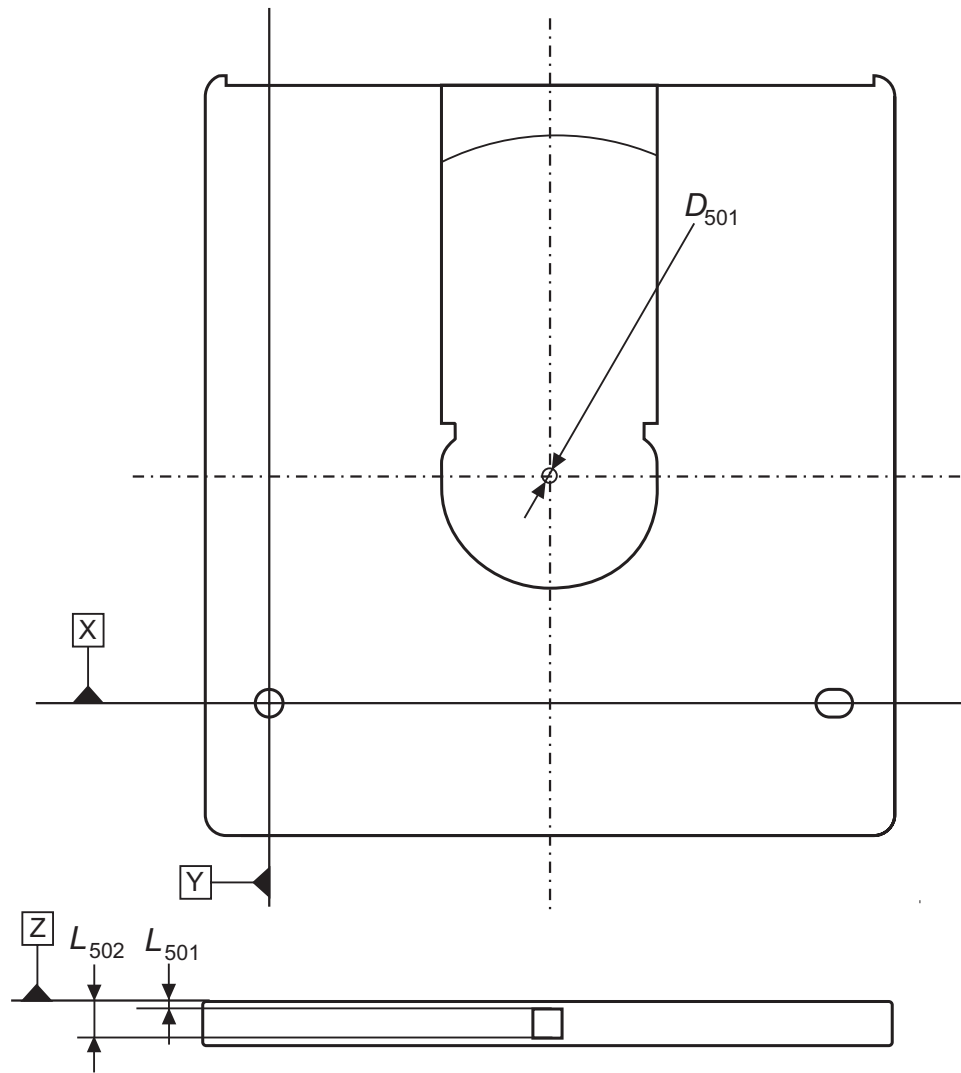

01-0072-A

Figure 50 - Capture cylinder

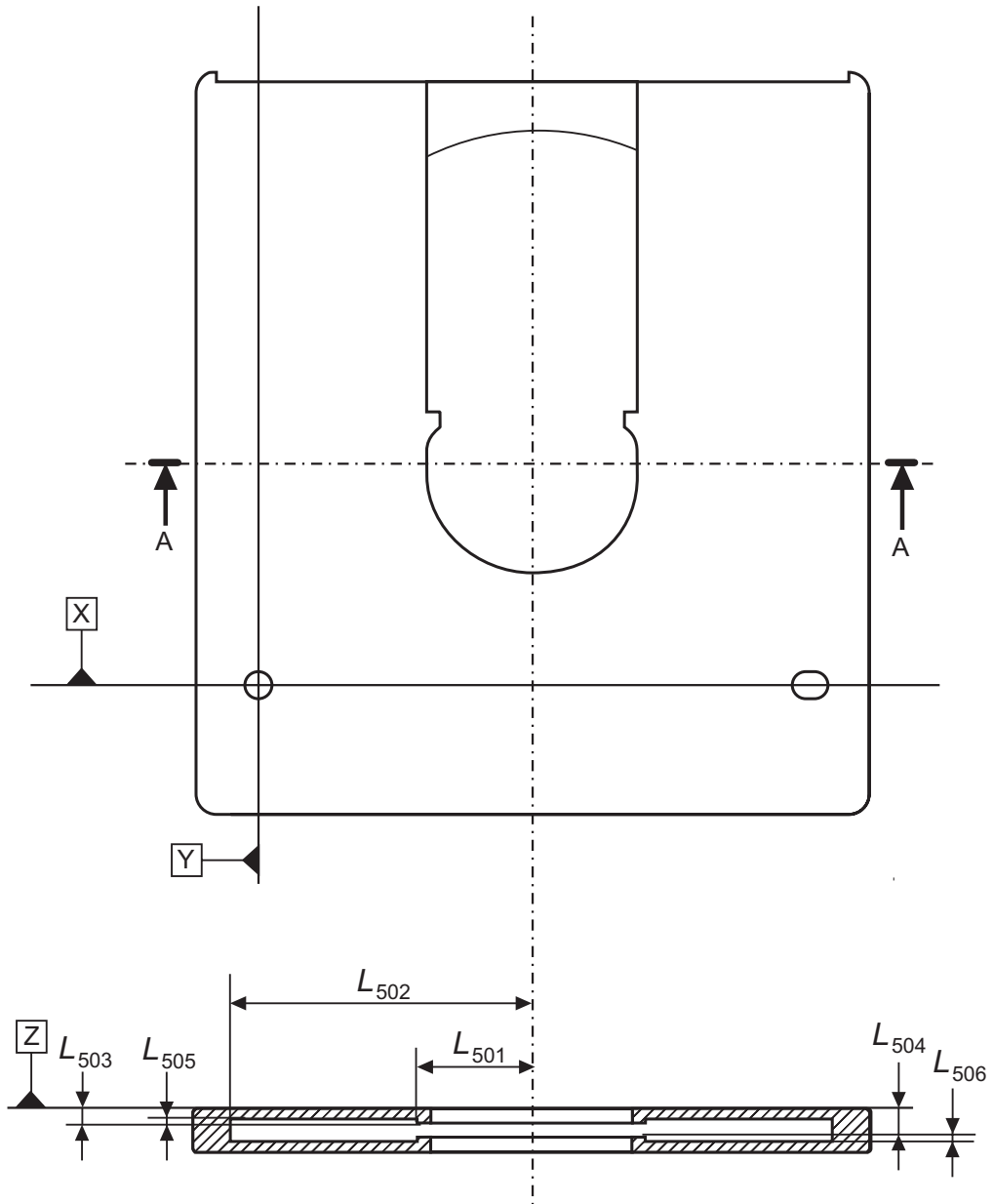

Section A-A

01-0073-A

Figure 51 - Inner dimensions of the case



Annex A
(normative)

Position of the case for 120 mm disk relative to the Reference Planes

This Annex shows the position of the case for 120 mm disk relative to the Reference Planes, as specified in 8.

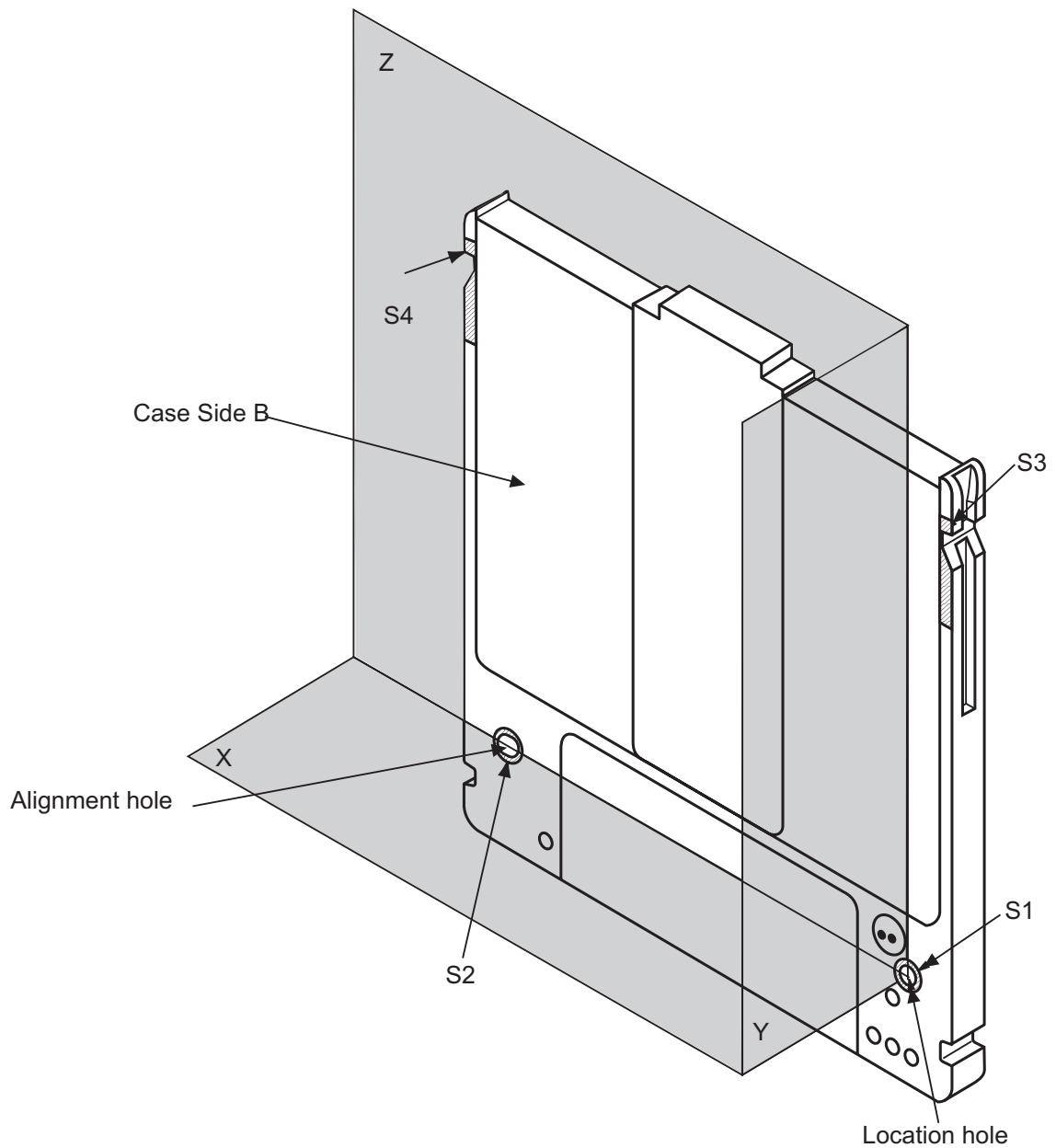

97-0117-A

Figure A.1 - Position of the case



Annex B (normative)

Edge distortion test of the case for 120 mm disk

The distortion test checks if the case is free from unacceptable distortions and protrusions along its edges. The test is made by causing the cartridge to pass through the vertical slot of a gauge.

B.1 Test gauge specification

The gauge shall be made of a suitable material, e.g. of chrome-plated carbon steel. The inner surfaces shall be polished to a surface finish of 5 μm peak-to-peak.

The dimensions shall be as follows (Figure B.1):

$$L_a = 136,0 \text{ mm min.}$$

$$L_b = 125,0 \text{ mm} \pm 0,1\text{mm}$$

$$L_c = 8,0 \text{ mm} \pm 0,1\text{mm}$$

$$L_d = 8,30 \text{ mm} \pm 0,02\text{mm}$$

$$L_e = 8,8 \text{ mm min.}$$

B.2 Requirements

When the cartridge is inserted vertically into the gauge, a vertical force of 1,5 N max. (without the cartridge weight) applied to the centre of the top edge of the cartridge shall cause the cartridge to pass through the gauge.

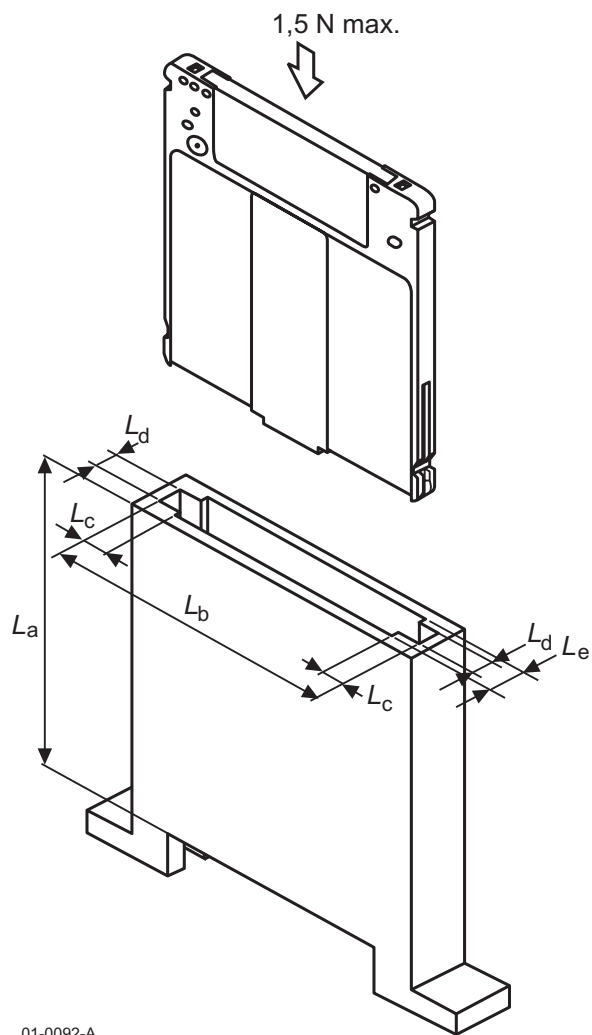

01-0092-A

Figure B.1 - Distortion gauge

Annex C (normative)

Compliance test of the case for 120 mm disk

The compliance test checks the flatness and flexibility of the case by forcing the four reference surfaces of the case into a plane. The test is made by placing the cartridge on the supports of a gauge and applying forces on the cartridge opposite to the supports.

C.1 Test gauge specification

The test gauge consists of a base plate on which four posts P_1 , P_2 , P_3 and P_4 are fixed so as to correspond to the four surfaces S1, S2, S3 and S4, respectively (Figure C.1). The location of the four reference surfaces S1, S2, S3 and S4 is defined in 8.1.4 (Figure 4) or 8.2.4 (Figure 14).

The dimensions are as follows (Figure C.2):

Posts P_1 and P_2

$$D_a = 6,50 \text{ mm} \quad \pm 0,01 \text{ mm}$$

$$D_b = 3,90 \text{ mm} \quad \begin{array}{l} + 0,02 \text{ mm} \\ - 0,00 \text{ mm} \end{array}$$

$$L_f = 0,5 \text{ mm} \pm 0,1 \text{ mm}$$

$$L_g = 3,0 \text{ mm} \quad \pm 0,1 \text{ mm}$$

The top area of posts P_1 and P_2 has a chamfer.

Posts P_3 and P_4

$$D_c = 5,00 \text{ mm} \pm 0,01 \text{ mm}$$

After assembly, both the upper annular surfaces with outer diameter D_a of the two posts P_1 and P_2 and the upper surfaces of the two posts P_3 and P_4 shall lie between two horizontal planes spaced 0,01 mm apart.

Positions of four posts P_1 , P_2 , P_3 and P_4

Each centre of posts P_2 , P_3 and P_4 shall be located at

$$L_h = 102,0 \text{ mm} \quad \pm 0,1 \text{ mm}$$

$$L_i = 11,0 \text{ mm} \quad \pm 0,1 \text{ mm}$$

$$L_j = 113,0 \text{ mm} \quad \pm 0,1 \text{ mm}$$

$$L_k = 90,0 \text{ mm} \quad \pm 0,2 \text{ mm}$$

from the centre of the post P_1 .

The cartridge shall be placed with its reference surfaces onto the posts of the gauge placed horizontally. A vertical downward force of 1,0 N shall be exerted on the cartridge opposite each of the four posts.

C.2 Requirements

Under the conditions of C.1, three of the four surfaces S1 to S4 shall be in contact with the surface of their respective posts, and any gap between the remaining surface S and the surface of its post shall not exceed 0,1 mm.

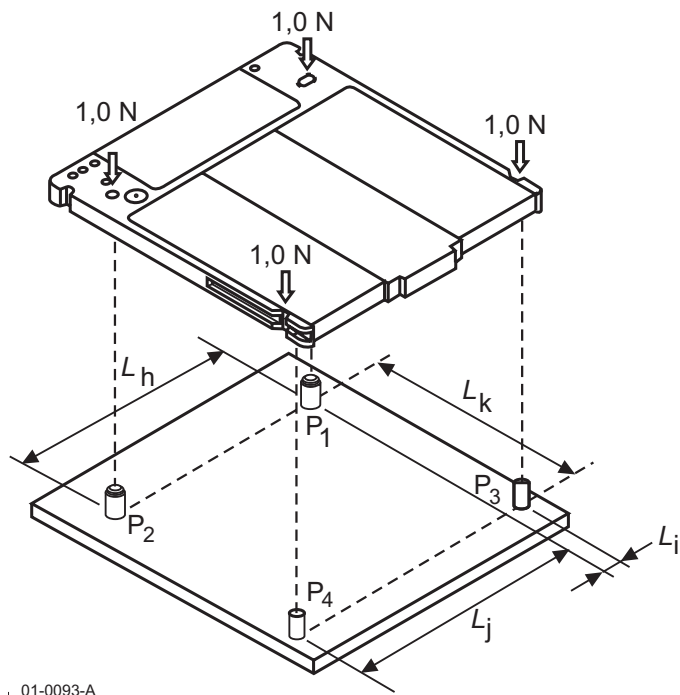

Figure C.1 - Compliance gauge

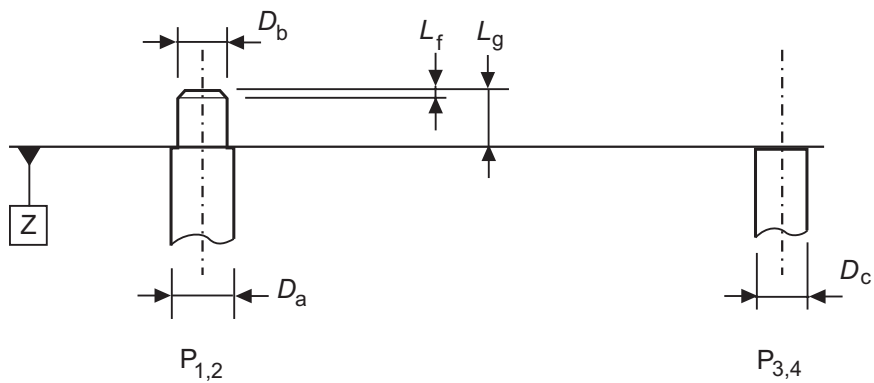
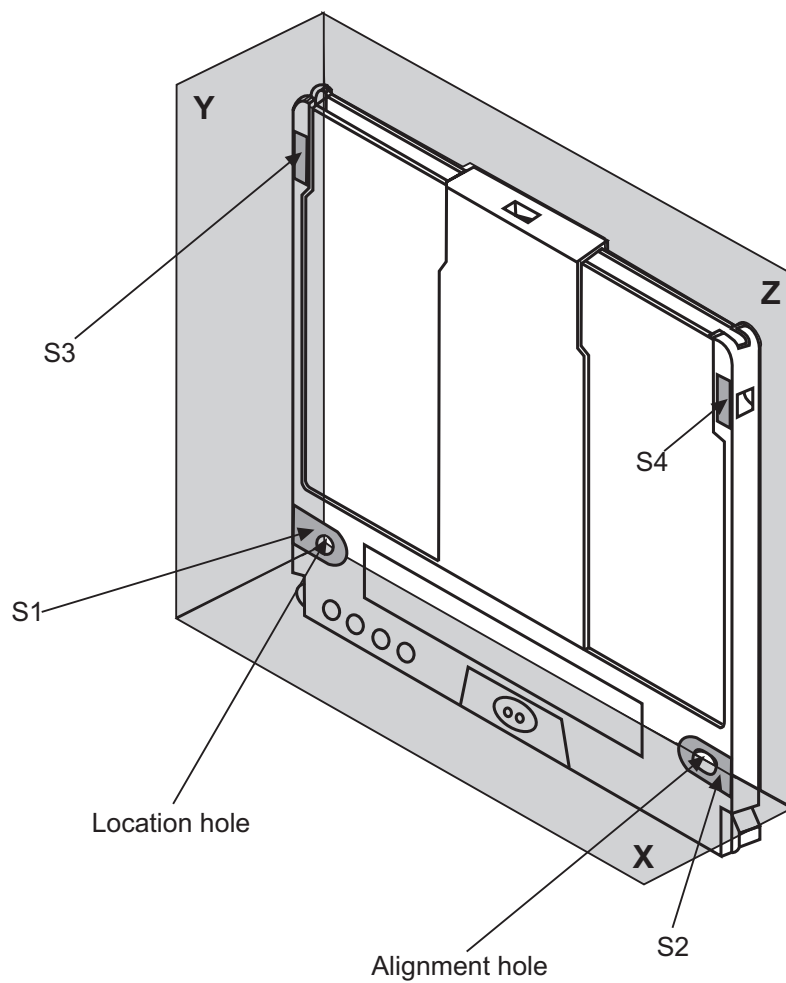

Figure C.2 - Detail of post

Annex D (normative)

Position of the case for 80 mm disk relative to the Reference Planes

This Annex shows the position of the case for 80 mm disk relative to the Reference Planes, as specified in 12.



01-0074-A

Figure D.1 - Position of the case



Annex E (normative)

Edge distortion test of the case for 80 mm disk

The distortion test checks if the case is free from unacceptable distortions and protrusions along its edges. The test is made by causing the cartridge to pass through the vertical slot of a gauge.

E.1 Test gauge specification

The gauge shall be made of a suitable material, e.g. of chrome-plated carbon steel. The inner surfaces shall be polished to a surface finish of 5 μm peak to peak.

The dimensions shall be as follows (Figure E.1).

$$L_a = 92,0 \text{ mm min.}$$

$$L_b = 89,6 \text{ mm} \pm 0,1 \text{ mm}$$

$$L_c = 6,0 \text{ mm} \pm 0,1 \text{ mm}$$

$$L_d = 5,70 \text{ mm} \pm 0,02 \text{ mm}$$

$$L_e = 6,2 \text{ mm min.}$$

E.2 Requirements

When the cartridge is inserted vertically into the gauge, a vertical force of 0,8 N max. (without the cartridge weight) applied to the center of the top edge of the cartridge shall cause the cartridge to pass through the gauge.

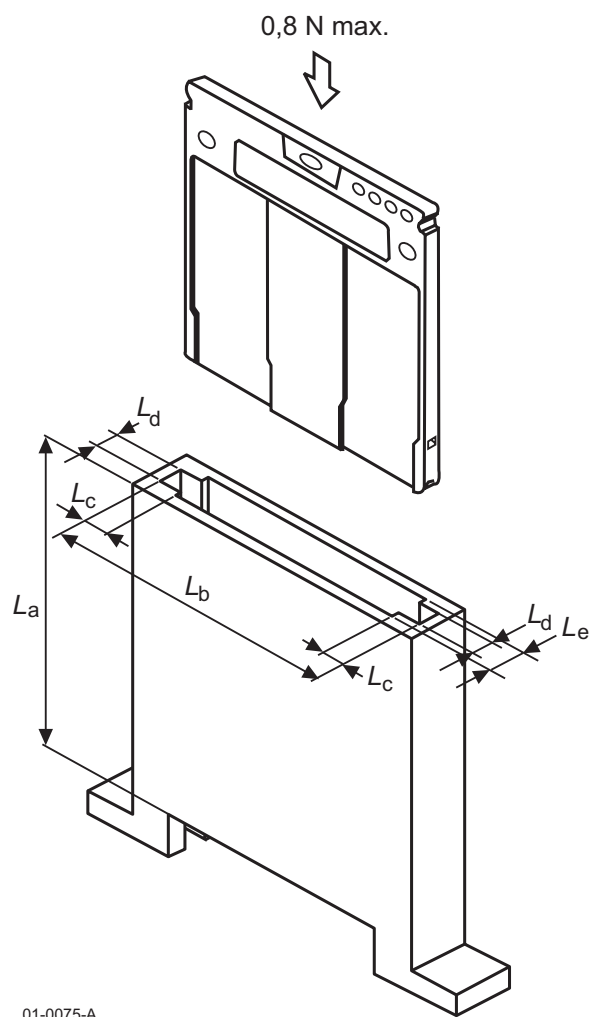

01-0075-A

Figure E.1 - Distortion gauge

Annex F (normative)

Compliance test of the case for 80 mm disk

The compliance test checks the flatness and flexibility of the case by forcing the four reference surfaces of the case into a plane. The test is made by placing the cartridge on the supports of a gauge and applying forces on the cartridge opposite to the supports.

F.1 Test gauge specification

The test gauge consists of a base plate on which four posts P_1 , P_2 , P_3 and P_4 are fixed so as to correspond to the four surfaces S1, S2, S3 and S4, respectively (Figure F.1). The location of the four reference surfaces S1, S2, S3 and S4 is defined in 12.1.4 (Figure 26) or 12.2.4 (Figure 37).

The dimensions are as follows (Figure F.2):

Posts P_1 and P_2

$$D_a = 5,50 \text{ mm} \pm 0,01 \text{ mm}$$

$$D_b = 2,90 \text{ mm} \begin{matrix} +0,02 \text{ mm} \\ -0,00 \text{ mm} \end{matrix}$$

$$L_f = 0,5 \text{ mm} \pm 0,1 \text{ mm}$$

$$L_g = 3,0 \text{ mm} \pm 0,1 \text{ mm}$$

The top area of posts P_1 and P_2 has a chamfer.

Posts P_3 and P_4

$$D_c = 4,00 \text{ mm} \pm 0,01 \text{ mm}$$

After assembly, both the upper annular surfaces with outer diameter D_a of the two posts P_1 and P_2 and the upper surfaces of the two posts P_3 and P_4 shall lie between two horizontal planes spaced 0,01 mm apart.

Positions of four posts P_1 , P_2 , P_3 and P_4 :

Each centre of posts P_2 , P_3 and P_4 shall be located at

$$L_h = 74,0 \text{ mm} \pm 0,1 \text{ mm}$$

$$L_i = 6,5 \text{ mm} \pm 0,1 \text{ mm}$$

$$L_j = 80,5 \text{ mm} \pm 0,1 \text{ mm}$$

$$L_k = 66,5 \text{ mm} \pm 0,2 \text{ mm}$$

from the centre of the post P_1 .

The cartridge shall be placed with its reference surfaces onto the posts of the horizontal gauge. A vertical downward force of 0,4 N shall be exerted on the cartridge opposite each of the four posts.

F.2 Requirements

Under the conditions of F.1, three of the four surfaces S1 to S4 shall be in contact with the annular surfaces of their respective posts, and any gap between the remaining surface S and the annular surface of its post shall not exceed 0,1 mm.

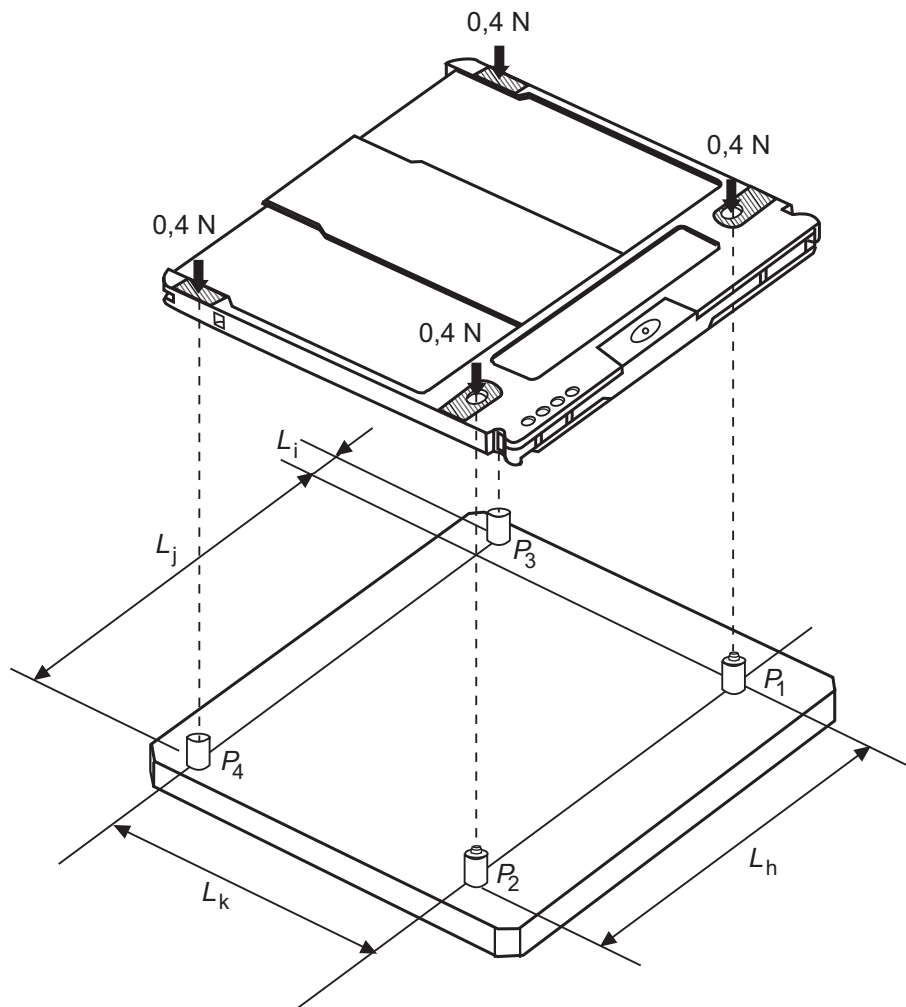

01-0080-A

Figure F.1 - Compliance gauge

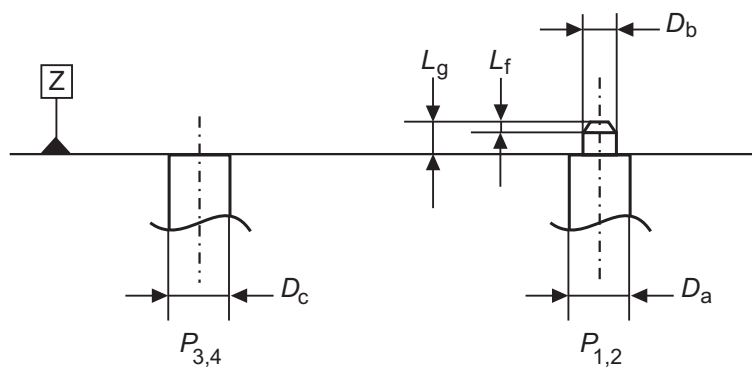

01-0079-A

Figure F.2 - Detail of posts

Annex G
(normative)

Shutter opening force test of the case for 80 mm disk

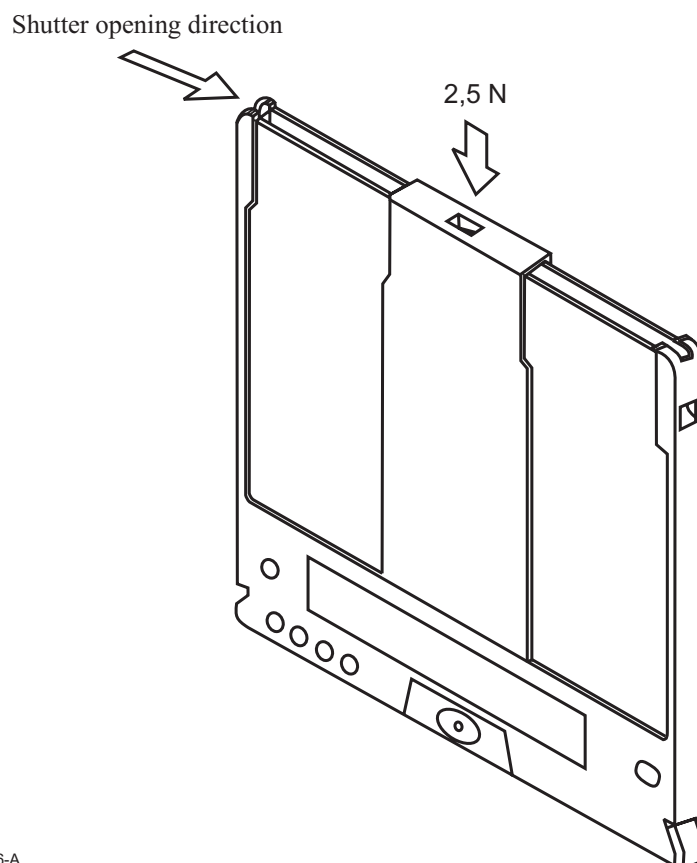

01-0076-A

Figure G.1 - Measuring method of shutter opening force



Annex H
(informative)

**Examples of an opening cover for a Type 2 case, a Type 3 case,
a Type 4 case or a Type 5 case**

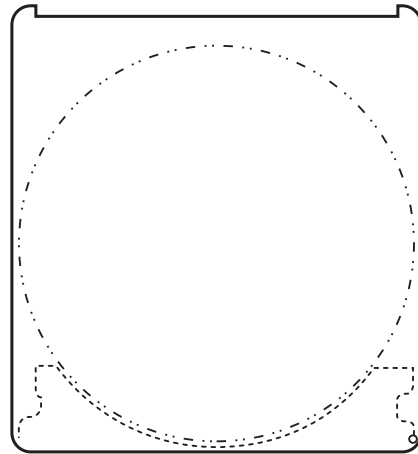

Cover closed

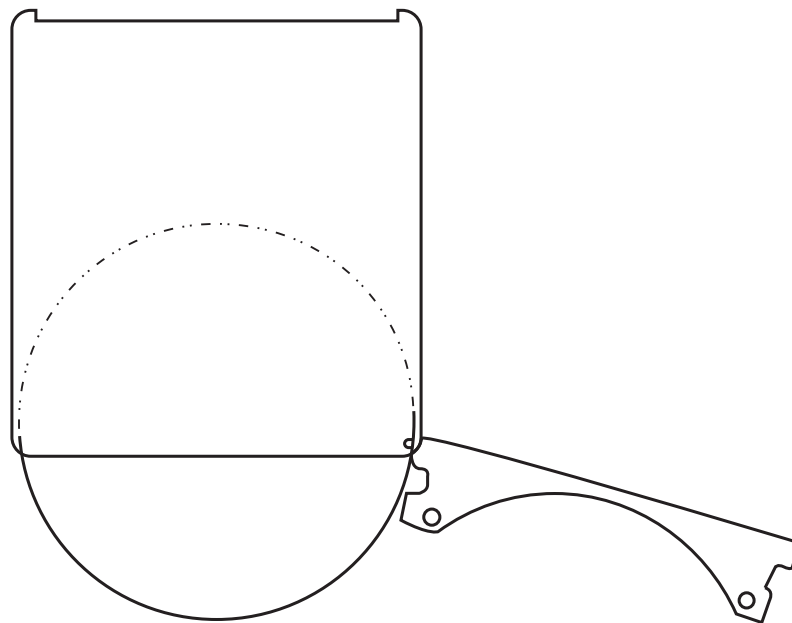

Cover open

97-0121-A

Figure H.1 - First example of an opening cover

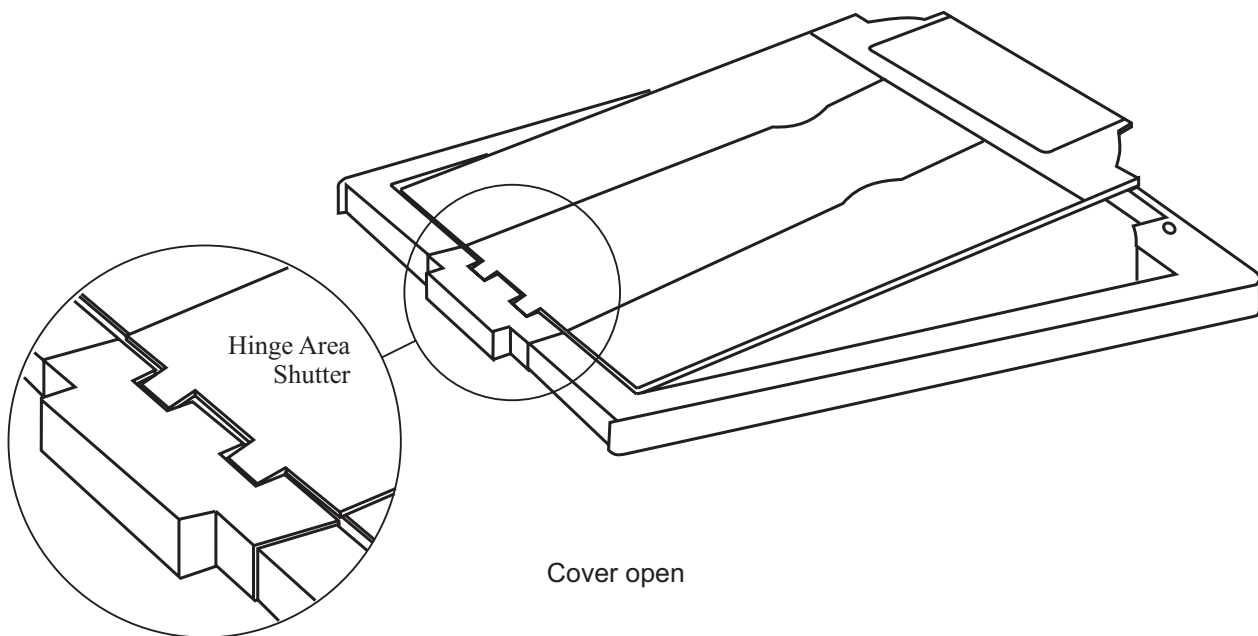
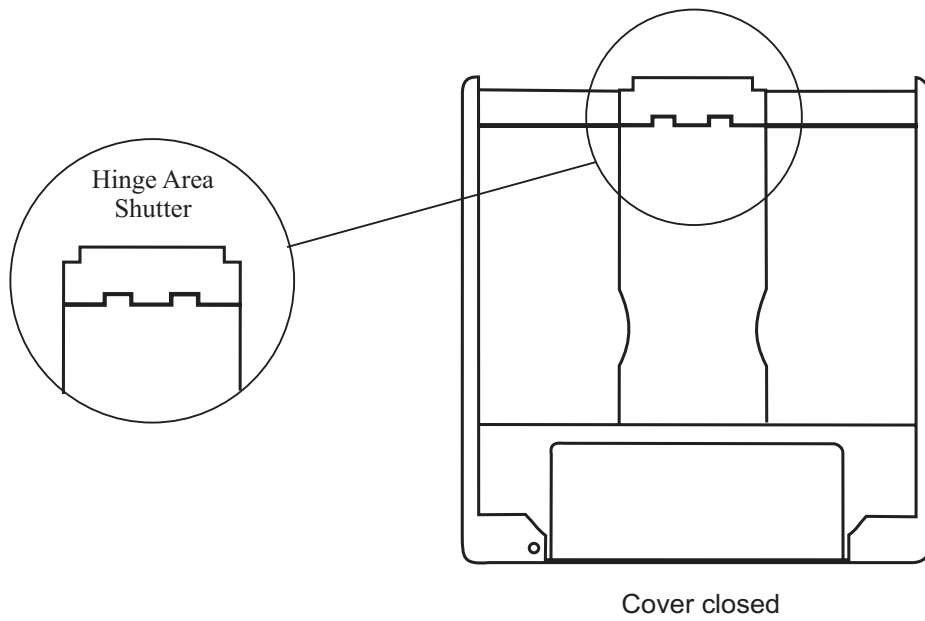

97-0130-A

Figure H.2 - Second example of an opening cover

Annex J
(informative)

**Connection between disk holder and body of the case
for 80 mm disk**

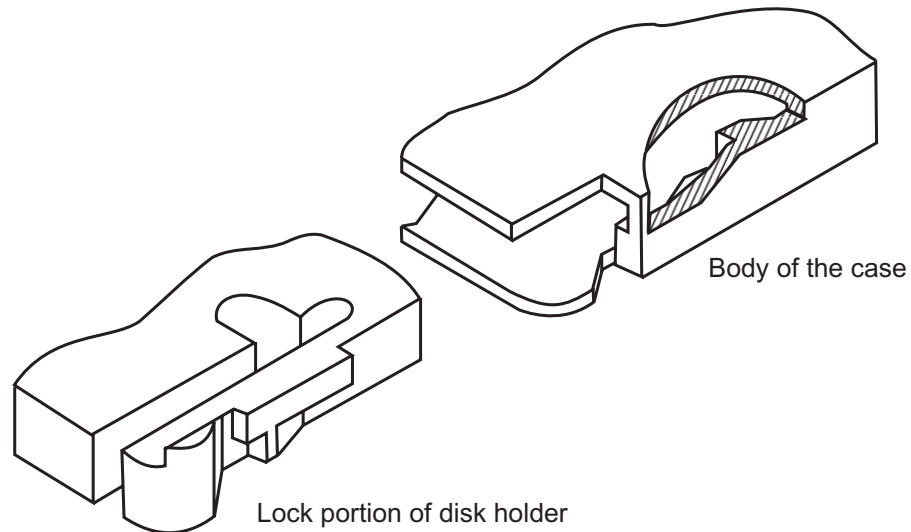

01-0077-A

Figure J.1 - Connection between lock portion of disk holder and body

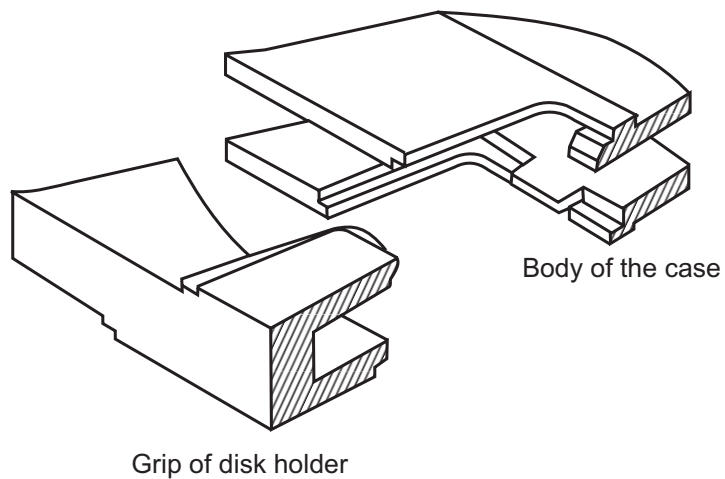

01-0078-A

Figure J.2 - Connection between grip of disk holder and body



Annex K (informative)

Transportation

K.1 General

As transportation occurs under a wide range of temperature and humidity variations, for differing periods, by many methods of transport and in all parts of the world it is not possible to specify conditions for transportation or for packaging.

K.2 Packaging

The form of packaging should be agreed between sender and recipient or, in the absence of such agreement, is the responsibility of the sender. It should take account of the following hazards.

K.2.1 Temperature and Humidity

Insulation and wrapping should be designed to maintain the conditions for storage over the estimated period of transportation.

K.2.2 Impact loads and vibration

Avoid mechanical loads that would distort the shape of the case or cartridge.

Avoid dropping the case or cartridge.

Cases or cartridges should be packed in a rigid box containing adequate shock-absorbent material.

The final box should have a clean interior and a construction that provides sealing to prevent the ingress of dirt and moisture.

